

Installation Instructions



BigRope™ Swinger

Model No. 4585-45

Revision History

Revision: 12/16/2022

All Rights Reserved

© Copyright 2022, NetPlay USA LLC

Printed in USA



Contents

- Introduction.....2
- General Information.....2
- Drawings/Views.....2
- Measurement Tolerances2
- Specifications3
- Parts List4
- Installation5-11
 - Part A: Site Prep and Use Zone5
 - Part B: Foundation6-8
 - Part C: Structure9-10
- Finishing11
- Final Checklist.....11
- Maintenance.....12
- Maintenance Log.....13
- Handover Document.....14



Please read through the entire installation instructions upon receipt to ensure that all parts have been received and that all customer-supplied materials are procured prior to the start of installation.

Introduction

Thank you for purchasing the BigRope™ Swinger! Before we begin, please take some time to familiarize yourself with the components, tools, and installation steps to ensure adequate preparation for a smooth installation.

General Information

This equipment should be installed, inspected, maintained, and operated in accordance with ASTM F1487-17 or CSA-Z614 guidelines.

The installation site shall have a flat and level surface with a maximum slope of 3%.

For product support, including questions regarding installation, or to obtain replacement parts, please contact your equipment dealer.



Following installation, the complete assembly instructions, maintenance instructions, and maintenance records must be sent to the operator who must confirm receipt in writing. See the last page of this document.

Drawings/Views

The manufacturer reserves the right to make reasonable changes to technical details of our products for enhanced safety and assurance for users and operators.

Measurement Tolerances

Due to the properties and characteristics of the components above surfacing level, actual measurements may vary from those indicated in the diagrams. The manufacturer has established safe tolerances for these components.

Specifications

Assembly Time..... 1 hours
(after completion of foundations)

Personnel Required 2

Equipment

Height..... 47.25 in (1200 mm)

Footprint..... 122 x 43.5 in
(3100 x 1100 mm)

Use Zone..... 266 x 188 in
(6760 x 4760 mm)

Fall Height 45.25 in (1150 mm)

Age Group 5 to 12 years

Capacity 8

Foundations

Concrete Mix C25/C30

Required Concrete (total) 61.03 ft³ (1.73 m³) foundations

Foundation Dimensions (x2) 71.0 x 31.5 x 23.5 inches
(1800 x 800 x 600 mm)

Drainage Stone (total) 10.32 ft³ (0.29 m³) total
(4 inches of stone required beneath each foundation)



In the case of sandy and soft soils, the size of the foundations must be enlarged by 50%.

Parts List

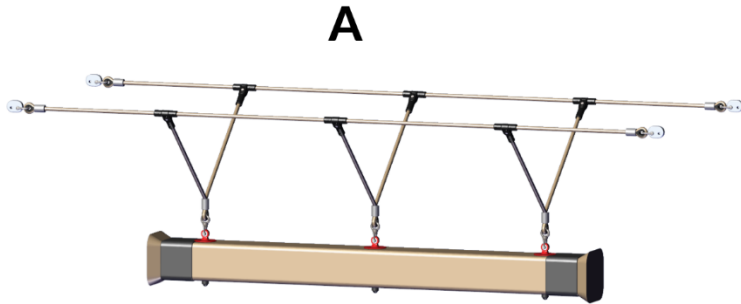

B

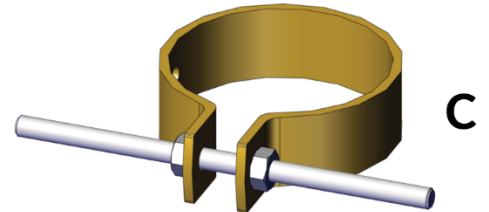

C

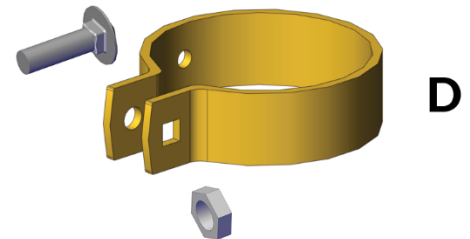

D

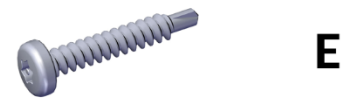

E

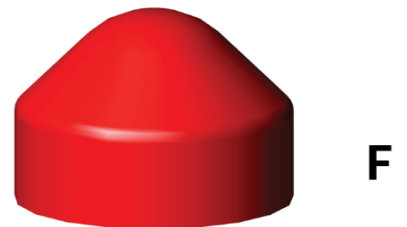

F



G

Part	Description	Qty
Included Parts		
A	Swinger Assembly	1
B	Steel Post	4
C	Post Base Clamp	4
D	Post Connecting Clamp w/bolt and nut	4
E	Self-Tapping Screw	12
F	Post Cap	4
G	Compliance Stickers	2
Supplied by Customer		
H	12 x 12 in Concrete Slab (patio paver)	4

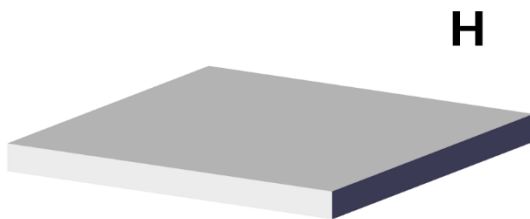

H

Installation

Part A: Site Prep and Use Zone

Be sure that the chosen site is well drained and level, with a 3% maximum slope.

A clear path and adequate protective surfacing are required 72 inches (1,829 mm) around the equipment. The use zone of the BigRope Swinger may not overlap any other use zone.

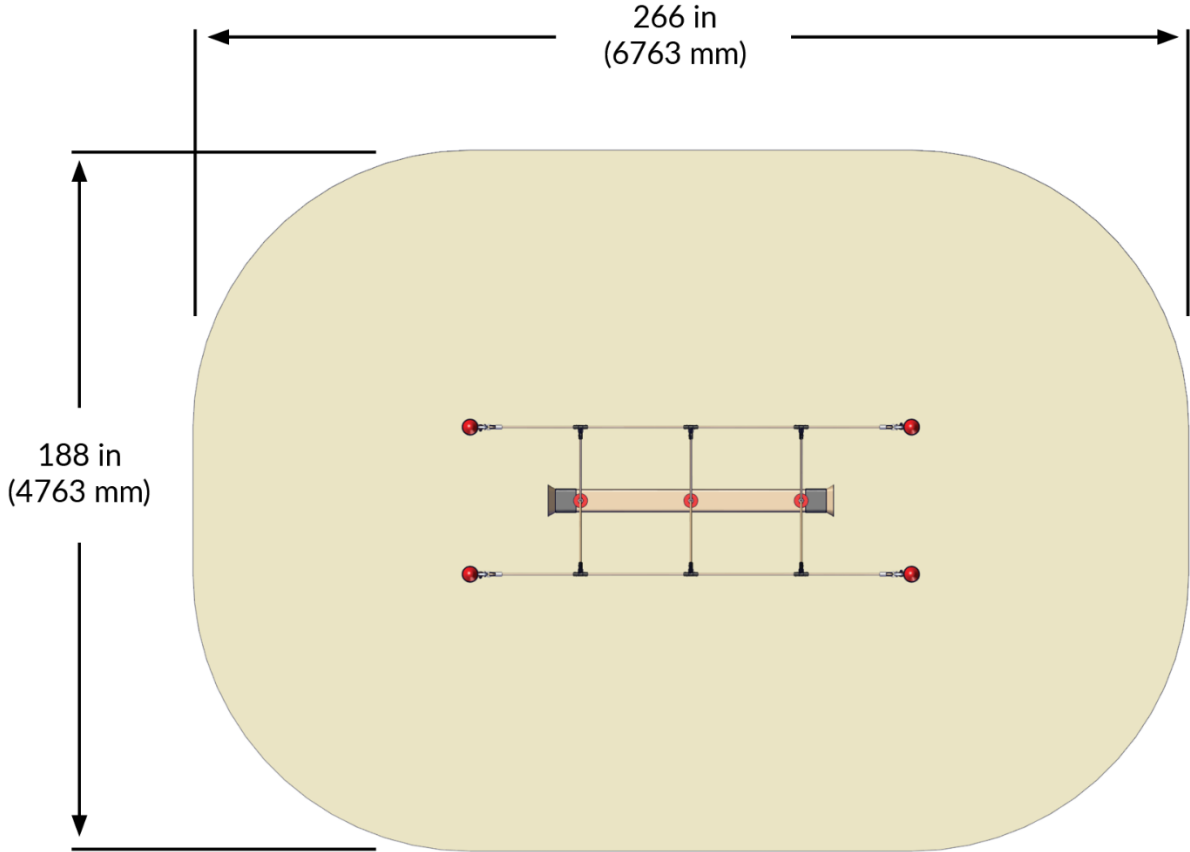

Installation

Part B: Foundation

- Two concrete foundations are required for the Catwalk Adventure Bridge. Use the diagram on the following page to find the exact locations and orientations of each foundation.
- Dig both foundation holes to the following dimensions which include 12 inches (300 mm) for surfacing over the foundations and 4 inches (100 mm) for drainage stone under the foundations (measured from final intended surfacing height):

Dig Dimensions: 70.87 inches long x 31.5 inches wide, and 39.5 inches deep (1800 long x 800 mm wide, and 1000 mm deep)



The required surfacing depth of 12 inches (300 mm) is critical to meet the manufacturer's specifications for safe use and compliance.

Please refer to ASTM F1292, ASTM F1951, ADA, and ABA standards when choosing the type and thickness of surfacing material.

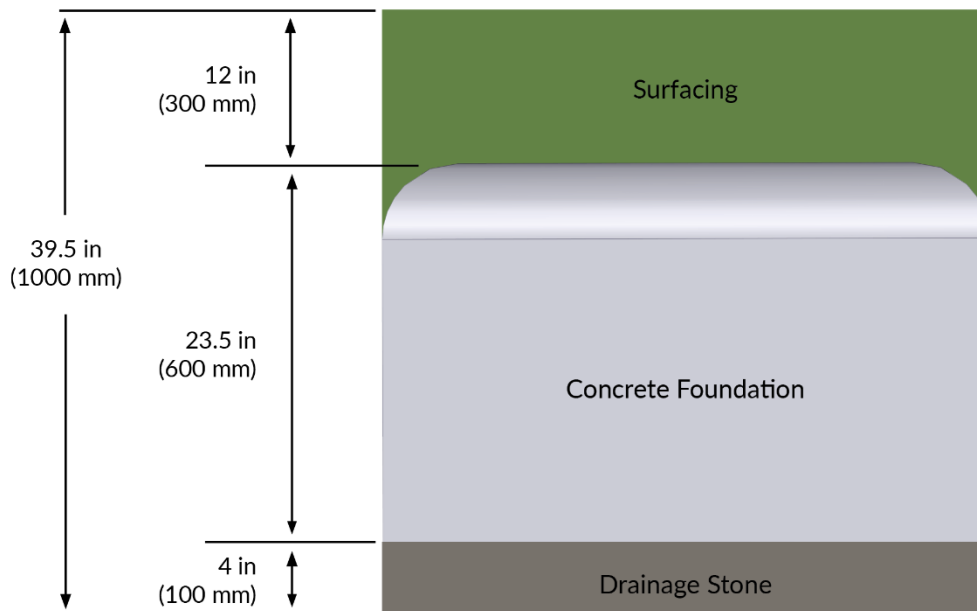



The dimensions between posts is critical to the proper fit of the net assembly. Please double check the measurements and ensure the posts will not move when the concrete is poured.

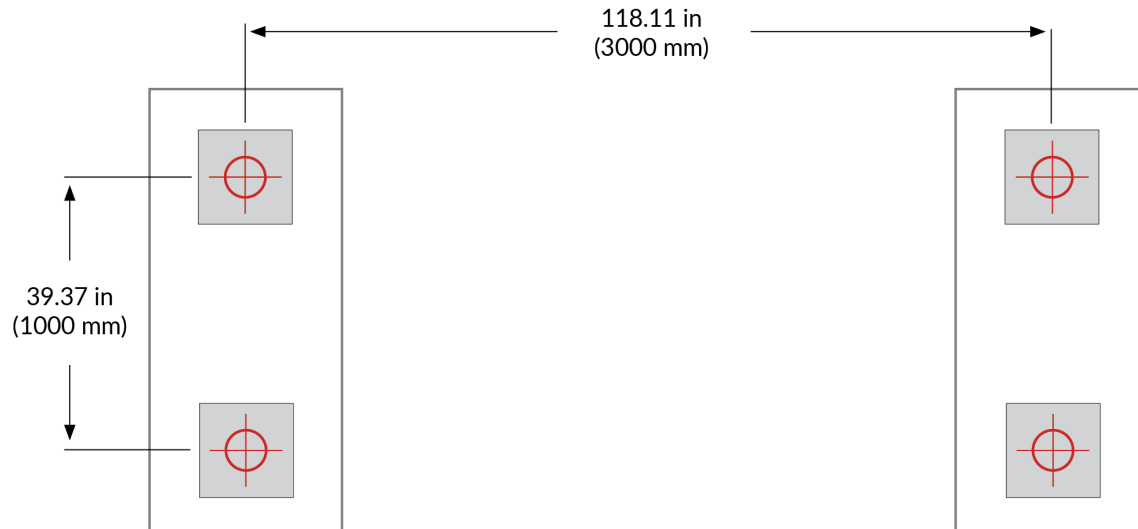

- Place 4 inches (100 mm) of drainage stone evenly on the bottom of each foundation hole.
- Place the concrete slabs (H) into the drainage stone at the positions shown above, so that the top of each slab is flush with the top of the drainage stone.
- The center of the slabs must be 39.37 in (1,000 mm) apart in each foundation. Between foundations, the center-to-center measurement on each side must be 118.11 in (3,000 mm). See diagram above.
- Slide a base clamp (C) about 8 in (200 mm) onto one end of each post (B) and tighten. The base clamp prevents the post from loosening in the concrete over time.



- With the clamp end down, place each post on-end onto the center of the concrete slabs.
- Use a level to make sure that each post is straight, Adjust the concrete slabs until all are plumb.
- As with the concrete slabs, check the measurements at the center point of each post and adjust as necessary.

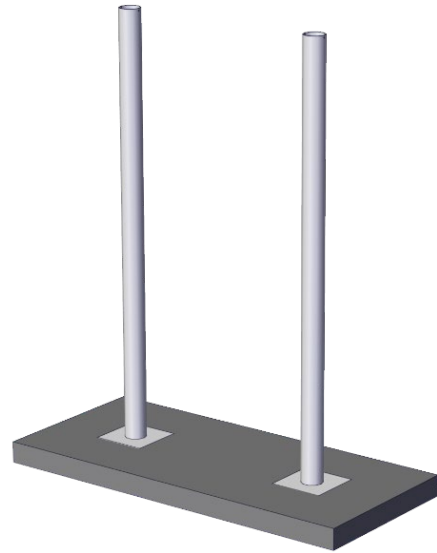
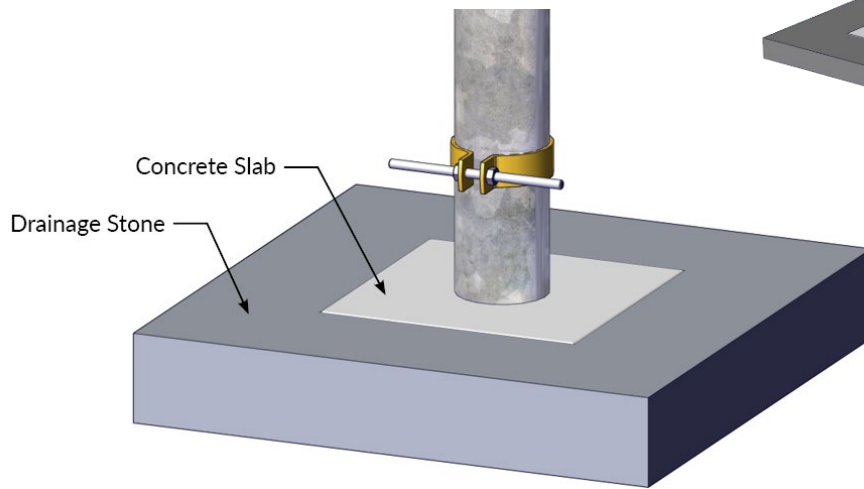

Concrete

- Pour both concrete foundations.
- Round the top corners of each foundation to a 4 in (100 mm) radius.
- Allow to set for the concrete manufacturer's recommended amount of time before proceeding to the next step.

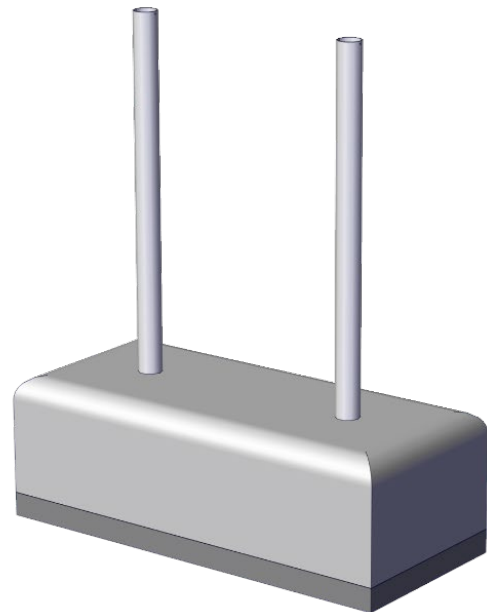



Apply at least 5 drops of thread locking adhesive (L) to the threads of all nuts, bolts, screws, and turnbuckles when installing. Do not apply thread locking adhesive to locknut (H).

In addition, the threads of stainless steel hardware must also be sprayed with Teflon spray or similar lubricant (not included) to prevent cold welding.

Stainless Steel Hardware

- **Post Connecting Clamp bolt and nut assembly**

Installation

Part C: Structure

- Slide a connecting clamp (D) onto the top side of each post. Do not tighten.
- Connect the attachment points of the net assembly (A) to the connection clamps on the posts as shown. Start with the two at one end of the net assembly, then the two at the other. See the Critical Dimensions diagram on the next page for heights and clearances.
- If the net assembly will not reach to connect to the posts, recheck the measurements between posts.

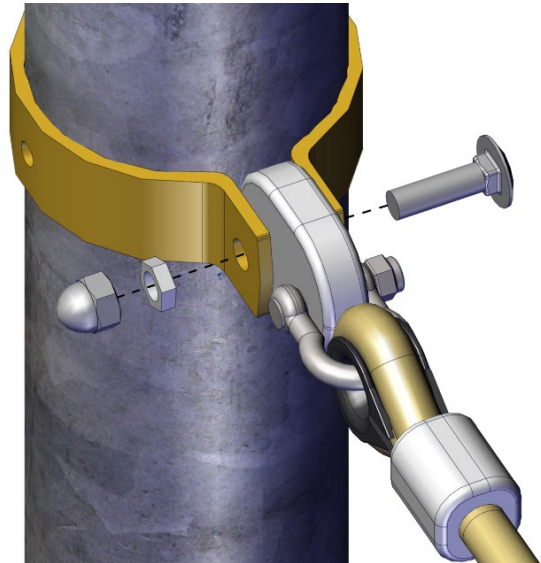

- Install the post caps (F) onto the top of all four posts. Use three self-tapping screws (E) for each post cap as shown. (Color may vary)

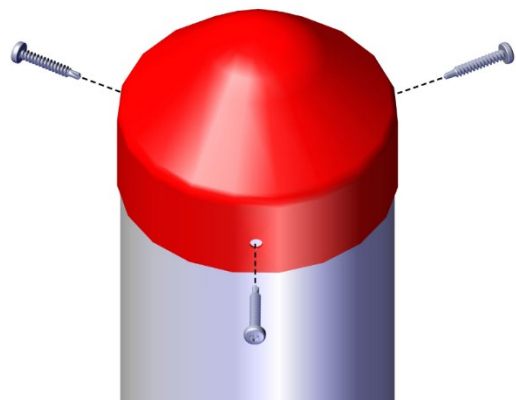

Critical Dimensions

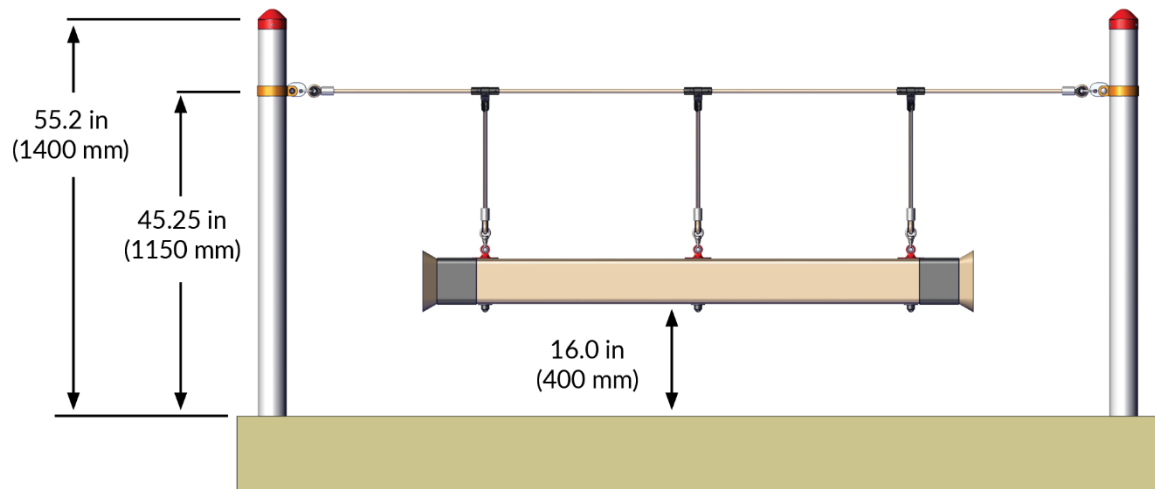

Finishing

- Place the two compliance stickers (B) onto the structure's posts – one on a post at each end of the structure. Make sure the surface of the post is clean and dry before applying the stickers.
- Apply and grade protective surfacing material to the use zone per ASTM F1292 until the 45.25 in (1150 mm) fall height is achieved, measured from the top rope at the connection points.
- If using loose fill, mark the posts at the final level of the surfacing material so that the proper level of fill can be maintained.
- Remove all tools, excess materials, or other assembly aids from the area prior to opening the equipment for play.

Final Checklist

Please make sure all following steps have been completed:

- () Checked that the net was correctly attached and/or tensioned.
- () Made sure the posts are level.
- () Applied all necessary surfacing and checked height measurements per ASTM F1292.
- () The product was installed to comply with ASTM F1487 or applicable local regulations.

Maintenance

To maintain safety, the operator must ensure that proper inspection and maintenance is carried out by a competent person in accordance with ASTM F1487-17 or CSA-Z614, and the following manufacturer recommendations.



Damage which may compromise safety must be repaired immediately. If repairs cannot be immediately carried out, the operator must close the equipment to prevent use.

Replacement Parts

Replacement parts may be obtained through your equipment dealer. Parts not obtained through a dealer must conform to the manufacturer's specifications.

Break-in Period

Between 1-2 weeks after installation (equipment break-in period), check all threaded connections and tighten if necessary. After the break-in period, the operator may follow the recommended inspection frequency.

Inspection Frequency

With average use and environmental conditions, check the following at or before the recommended frequency. If the equipment is exposed to regular high-use or harsh environments, the inspections should be performed at a shorter frequency. Inspections should also be completed per ASTM 1487-17 or CSA-Z614 guidelines.

Monthly

- Check all connecting elements and fittings for wear and tear and tighten if necessary. Repair or replace damaged or missing parts.
- Check ropes for excessive wear. If ropes are worn through to the steel wire core, the equipment should be closed to prevent use until the rope is repaired or replaced.

Quarterly

- Check surfacing for adequate depth and fill in as necessary.
- Check the stability of the foundations and post.

Yearly

- Check for corrosion on metal components. It may be necessary to dig out subterranean components to inspect them. Apply zinc paint to any corroded or scratched areas.

New Product Handover



Model Name: BigRope™ Swinger
Model Number: 4585-45
Serial Number: _____



Operator

Name of operator (town, school, business, etc.): _____

Street: _____ City: _____ State: _____ Zip: _____

Representative in charge: _____

Installer

Name of installation company: _____

Street: _____ City: _____ State: _____ Zip: _____

Representative in charge: _____

Installer Checklist:

- Adequate concrete foundations poured per instructions.
- Structure assembled per the instructions without modification (unless approved by the manufacturer.)
- Final inspection conducted and passed per instructions.

Operator received the complete assembly instructions, inspection & maintenance instructions, and maintenance log. Installer completed work to the manufacturer's specifications.

Operator Signature: _____ Date: _____

Installer Signature: _____ Date: _____