

---

**A Assembly Instructions  
Pirates Tower  
Art. 4687-20S**

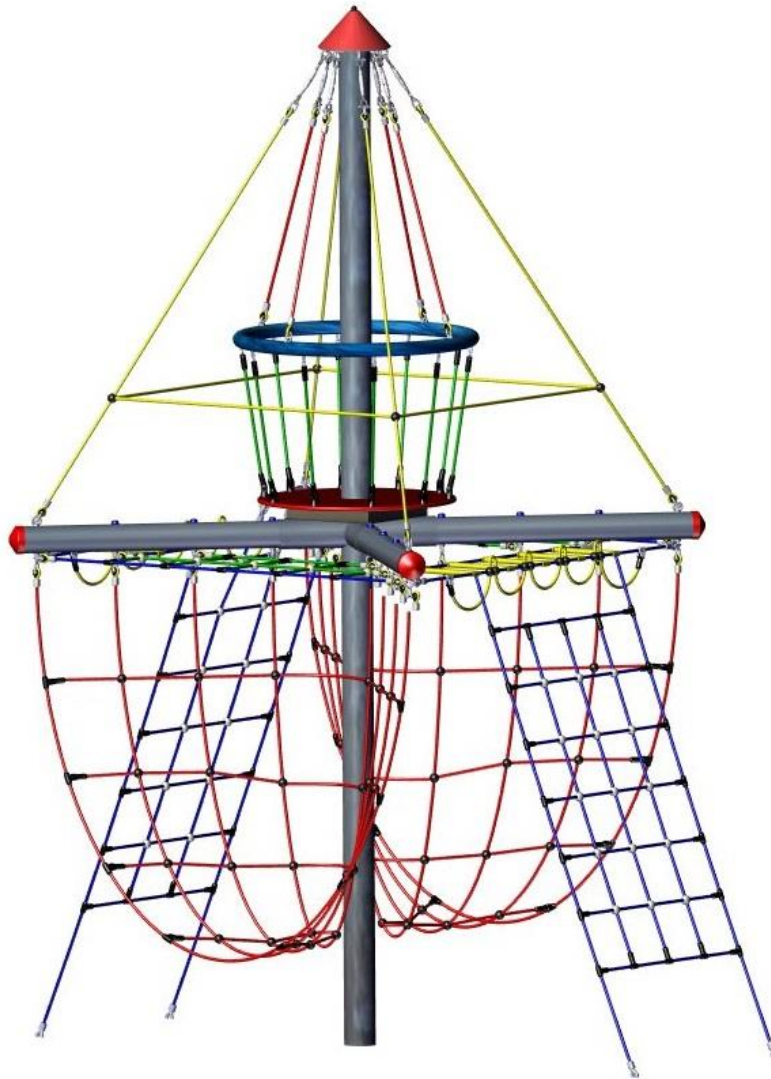

**Operator:** \_\_\_\_\_

**Location:** \_\_\_\_\_



**Revision history**

Revision 0 – 2017-02-07

Revision 2 – 2018-11-07 Änderungen n. Angaben v. JF, FH

The first allowed version

Assembly Instructions

All rights reserved

© Copyright 2017 Huck Seiltechnik GmbH

---

## Contents

<b>A</b>	<b>Assembly Instructions Pirates Tower Art. 4687-20S.....</b>	<b>1</b>
1	Introduction Assembling .....	4
2	Data sheet: Pirates Tower, Art. 4687-20S.....	6
3	Delivery contents (parts list with part numbers) .....	8
4	Post installation checks .....	34
5	Introduction Maintenance .....	19
6	General maintenance information.....	20
7	Maintenance timetable .....	22
8	Monthly maintenance .....	23
9	Quarterly maintenance .....	24
10	Half yearly maintenance.....	24
11	Annual maintenance.....	25
12	Maintenance printout.....	26
13	Hand over document .....	28

## List of Tables

Table 3-1: Delivery contents, in words .....	8
Table 3-2: Delivery contents, in symbols.....	10



The equipment must be installed by someone with the necessary expertise in strict compliance with the instructions from Huck Seiltechnik GmbH that are delivered with the equipment. **Use only the Installation instructions that are delivered with this equipment!**

A copy of the installation record should be given to the operator, who must confirm receipt.

---

---

# 1 Introduction Assembling

## 1.1 General information

This equipment should be installed, inspected, maintained and operated in accordance with ASTM F1487-17 guidelines.

**Before installation work commences, please check that you have all of the equipment and fixation components in the parts list provided (see Tables 3-1 and 3-2).**

**Please consider that the installation has to be carried out only on level terrain (max.slope up to 3%).**

Any spare parts that may be required can be obtained directly from your supplier.

Please do not hesitate to call your supplier if you have any problems during installation or in case of any other questions.



**Attention**

After installation the complete assembly instructions, maintenance instructions and a maintenance record must be sent to the operator who must confirm receipt in writing. See the last page of this document.



**Attention**

All nuts and bolts are hot-dip galvanised or stainless steel.

One of the characteristics of stainless steel is that uncontrolled cold welding may occur when the nuts are tightened. To prevent this, it is necessary to spray the nuts and bolts with Teflon spray or another similar lubricant.

---

**We hereby confirm that this play equipment has been tested and certified in accordance with the play equipment standard ASTM F1487-17.**

---

## **Drawings / Views**

All optical drawings are showing only the measurements/dimensions and are not standard technical views of the complete item. The Images (individual drawings) are not to scale!

We reserve the right to change technical details of our articles which are serving for the further development of our articles and are reasonable for the customer.

## **Measurement tolerances**

Because of the properties and characteristics of the components, minor measurement tolerances compared to the indication on the sketches are possible. This concerns all shown measurements except the foundation measurements below upper edge ground level/play area.

## 2 Data sheet: Pirates Tower, Art. 4687-20S

1. Component zone: 147.6 “ X 96.5 “
2. Safety zone: 292.52” x 244”
3. Fall height: 108.2 “
4. Minimum compressed loose-fill surfacing depths (refer to ASTM F1292 and ASTM F2223-10)

Inches	of (loose fill material)	Protects to	Fall height (feet)
5.5*	Shredded/recycled rubber		9.1
20,5	Sand		9.1
16.4	Pea gravel		9.1
11.7	Wood mulch(non-CCA)		9.1
8.2	Wood chips		9.1
*Shredded/recycled rubber loose-fill surfacing does not compress in the same manner as other loose-fill materials. However, care should be taken to maintain a constant depth as displacement may still occur.			

5. Name and overall dimension of the largest component:  
1x Steel post length 236.22”, Ø 6.26”
6. Name and weight of the heaviest component:  
1x Steel post, approx. 353 pounds
7. Intended age group: 5 to 12 years

**Please note that this equipment is set in concrete.**

Concrete: C25/30

Required concrete: 60 ft<sup>3</sup>

Foundations/area to be excavated: excavated (All foundations must be brought to equal level!)

**1 x 47.24” long x 47.24” wide x 27.56” high, total depth 43.31” including 3.94” drainage**

**1 x 59.06” long x 15.75” wide x 19.69” high, total depth 43.31” including 3.94” drainage**

**1 x 63” long x 15.75” wide x 19.69” high, total depth 43.31” including 3.94” drainage**

**1 x 15.75” long x 15.75” wide x 27.56” high, total depth 43.31” including 3.94” drainage**



Attention!

**Round off foundation edges (min.R = 100 mm)! Types of foundation soil are “A&B” (natural ground).**

---

**Soil type A:** Cohesive, plastic soils with unconfined compressive strength greater than 1.5 ton per square foot (tsf)(144 kPa), and meeting several other requirements (with a lateral soil pressure of 25 psf per ft of depth).

**Soil type B:** Cohesive soils with unconfined compressive strength between 0.5 tsf (48 kPa) and 1.5 tsf (144 kPa), or unstable dry rock, or soils which would otherwise be Type A (with a lateral soil pressure of 45 psf per ft of depth).

**In case of sandy and soft soils, the total size of the foundations have to be enlarged by at least 50%!**

8. Assembly time, once foundations completed: 4 hours.  
Required assistants: 3 persons.
9. Any spare parts which may be required can be obtained directly from your supplier.
10. We hereby confirm that this item of play equipment has been tested and certified in accordance with the play equipment standard ASTM F1487-17.

### 3 Delivery contents (parts list with part numbers)

#### 3.1 In words

Table 3-1: Delivery contents, in words



Pos.	Quantity	Element / Description	Size	O.K.	Missing
1	1	Steel post	Ø 6.26" X 236.22" long		
2	4	Steel beams	Ø 5.51" X 64.96" long		
3	1	Upper play element (preassembled)			
4	1	Lower play nets (preassembled)			
5	1	Tensioning ropes with circular connecting rope (preassembled)			
6		Connection plate	Ø 14.17" x 12 thick		
7	8	torx screws	4,25 x 25 mm		
100	4	Threaded bolt with 2 acorn nuts and 2 washers	M10 x 175 mm		
101	8	Carriage bolts	M8 x 40		
102	8	Washers	For M8		
103	8	Acorn nuts	M8		
104	4	Hexagon bolts	M12 x 30		
105	12	Toothed washer	For M12		
106	8	Hexagon bolts	M12 x 25		
107	8	Net components	M12		
108	6	Ring nuts	M12		
110	16	Washers	For M12		
111	12	Nyloc nuts	M12		
112	12	Nut caps	For M12		
113	9	Threaded pins	For 0.39" shackle		
114	2	Hexagon nuts	M16		
115	1	Threaded bolt	length of thread bolt M16 x 165mm		
116	1	Mast cap	Ø 14.17"		
117	1	Washer	For M16		
119	1	Nyloc nut	M16		









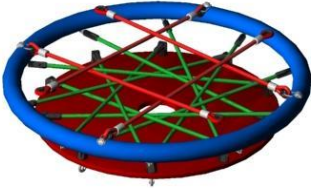
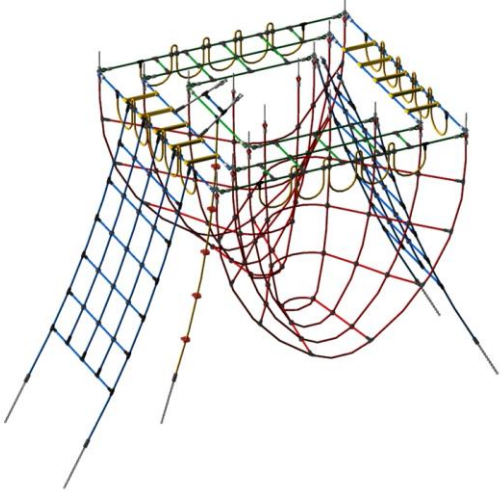
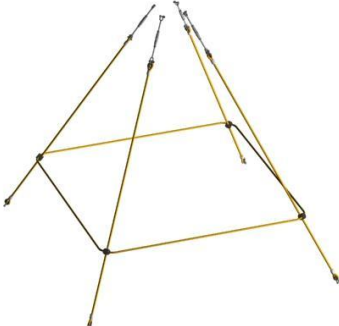

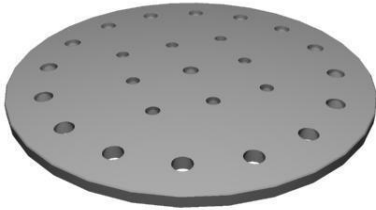



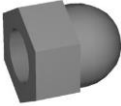

Pos.	Quantity	Element / Description	Size	O.K.	Missing
121	5	Anker chains	Ø 0.28" – 37.8" lg.		
122	4	Steel beam caps	Ø 140 mm		
123	12	Self tapping screws	5.5 x 25 mm		
124	2	Loctite			
125	2	Threaded bolt	M12 x 250 mm		
126	4	Hexagon nuts	M12		
127	5	Ground pegs	6mm		
128	5	Bow shackle	10 mm		
129	5	Bow shackle	6 mm		
130	12	Torx screws	4 x 25 mm		
	<b>1</b>	<b>Middle Foundation Pipe (provided by Customer)</b>	<b>Ø 10" X 29" long</b>		

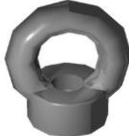



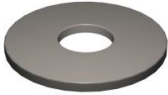
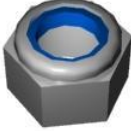

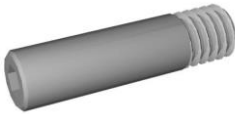
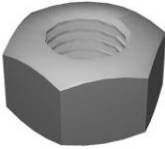

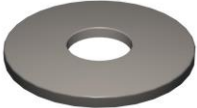

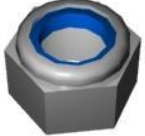

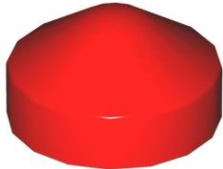
### 3.2 In symbols

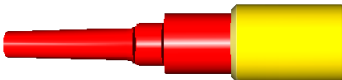
Table 3-2: Delivery contents, in symbols

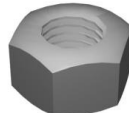
Pos.	Quantity	Symbol
1	1	 <p data-bbox="746 734 1075 819">Steel post Ø 6.26" x 236.22" long</p>
2	4	 <p data-bbox="799 880 1023 916">Ø 5.51", 64.96"</p>
3	1	
4	1	
5	1	

Pos.	Quantity	Symbol
6	1	 <p>Ø 14.17"</p>
7	8	 <p>4,25 x 25 mm</p>
100	4	 <p>M10 x 175 mm</p>
101	8	 <p>8 x 40 mm</p>
102	8	 <p>Ø 8,4</p>
103	8	 <p>M8</p>
104	4	 <p>M12 x 30 mm</p>
105	12	 <p>Toothed washer for M12</p>
106	8	 <p>M12 x 25 m</p>
107	8	 <p>M12</p>

Pos.	Quantity	Symbol
108	6	 <p>M12</p>
110	16	 <p>for M12</p>
111	12	 <p>M12</p>
112	12	 <p>for M12</p>
113	9	 <p>M10</p>
114	2	 <p>M16</p>
115	4	 <p>M16 x 165 mm</p>
116	1	
117	4	 <p>for M16</p>

Pos.	Quantity	Symbol
119	1	 <p>M16 Ground pins</p>
121	5	 <p>Ø 0.28" – 37.8" long</p>
122	4	 <p>Ø 5.51"</p>
123	12	 <p>5.5 x 25 mm</p>
124	2	
125	2	 <p>M12 x 250 mm</p>
126	4	 <p>M12</p>
127	5	
128	5	 <p>0.39"</p>
129	5	 <p>0.24"</p>
130	12	 <p>4,25 x 25 mm</p>
	1	 <p>Middle Foundation Pipe (provided by Customer)</p>

Pos.	Quantity	Symbol
		<b>1 piece</b> ca. Ø 11.81", 27.56" long

## Loctite-Thread locking adhesive!

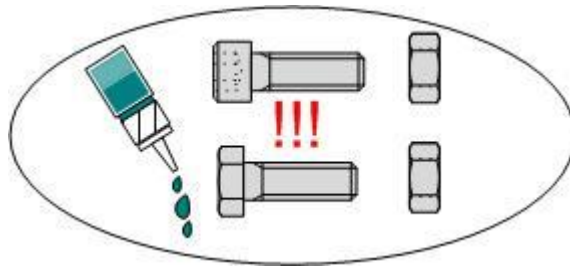

Glue all screws, nuts and sleeves with loctite.  
(Not less than 5 drops!)  
(Except for Nyloc nuts)

4 Erection instructions

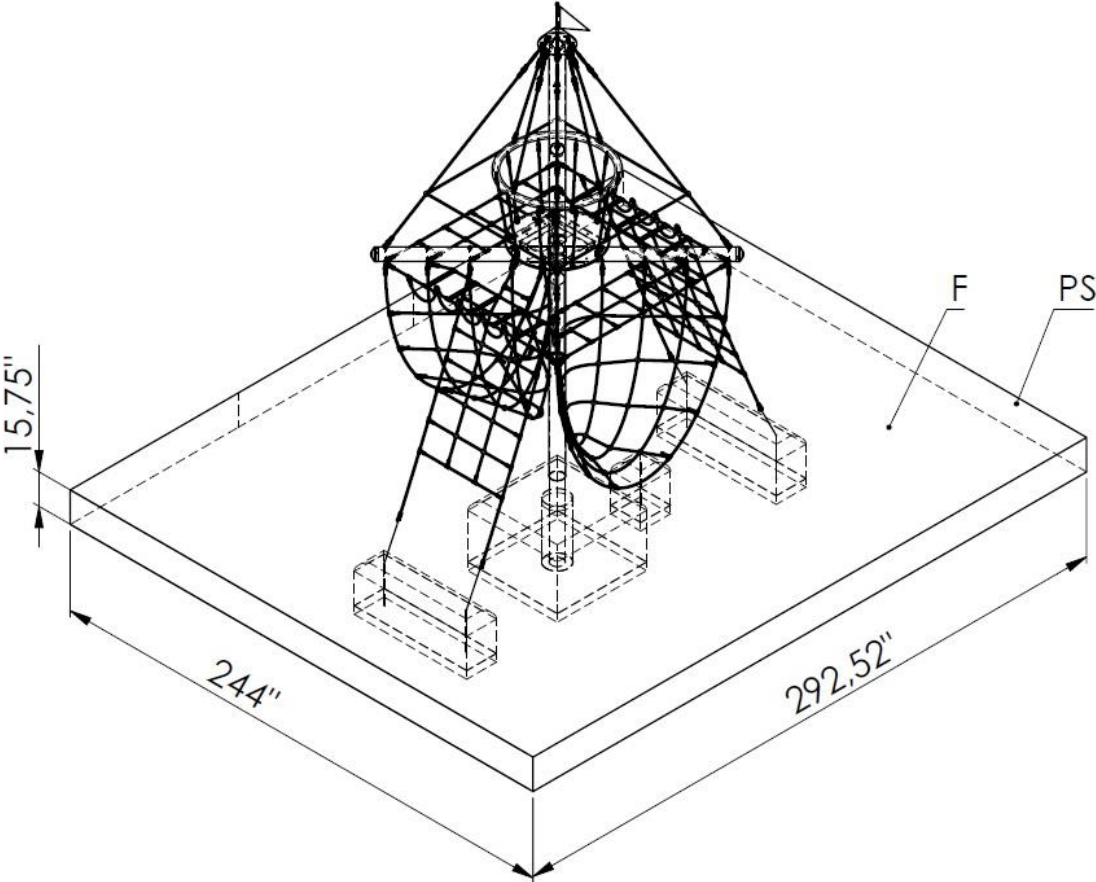

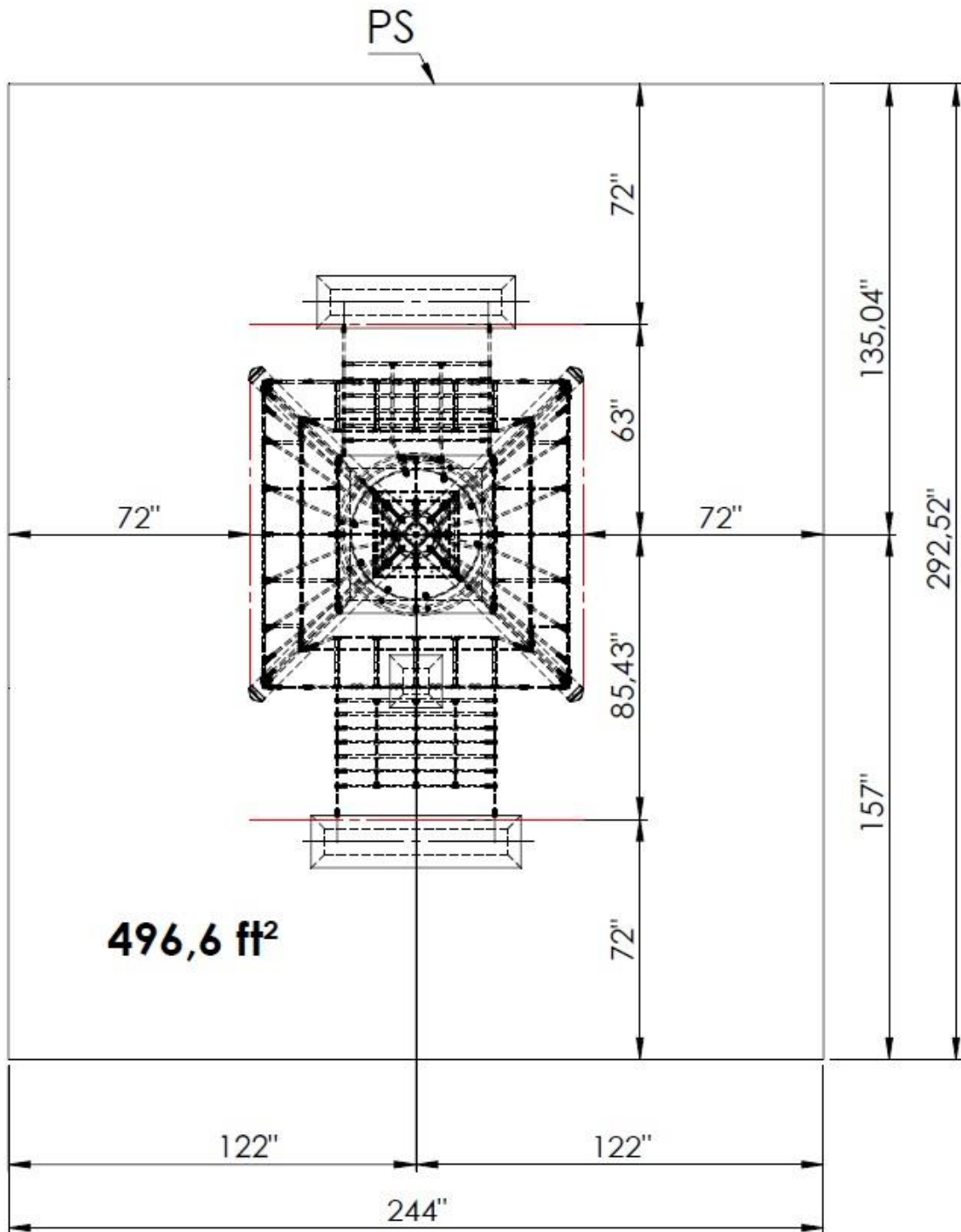



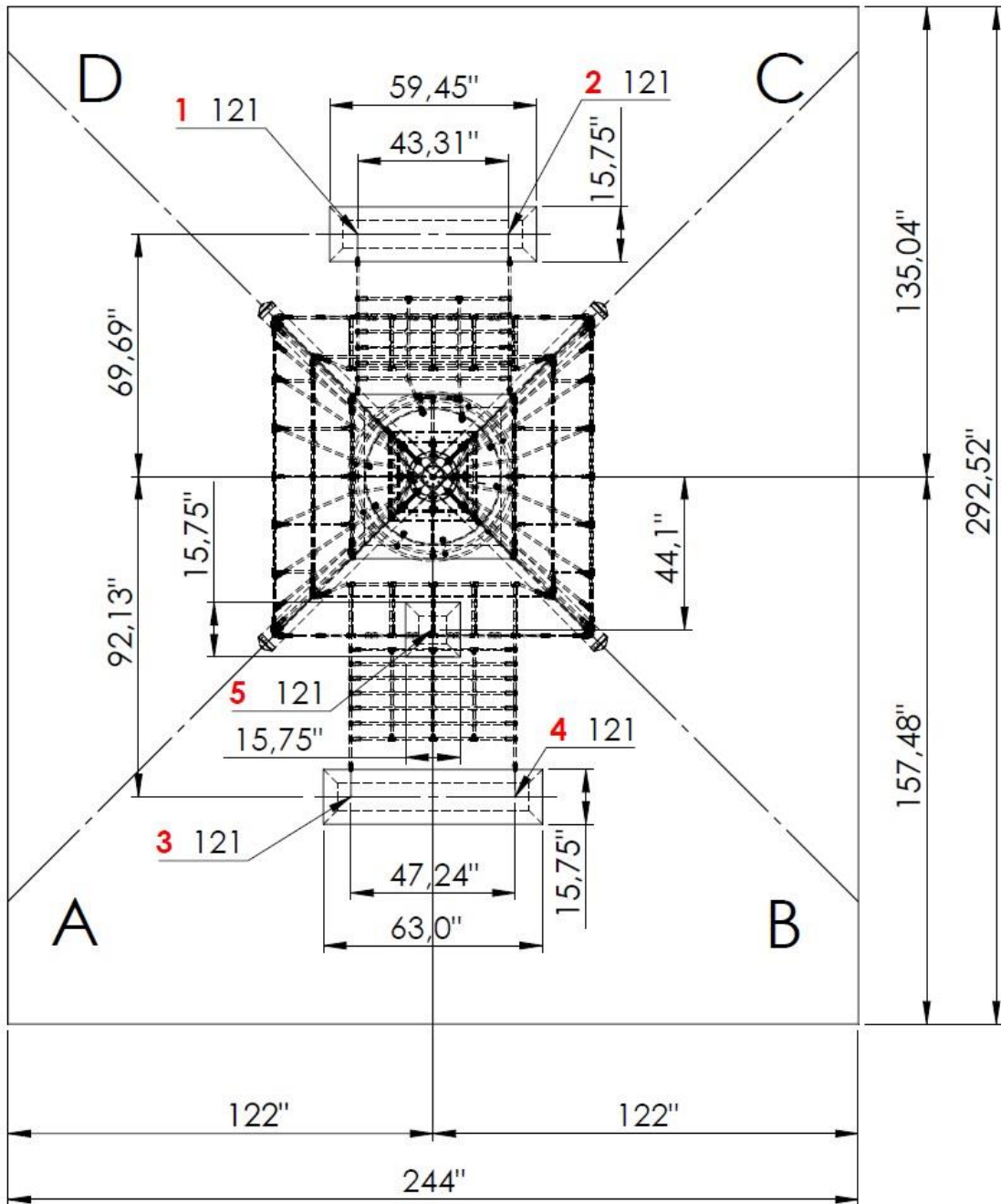

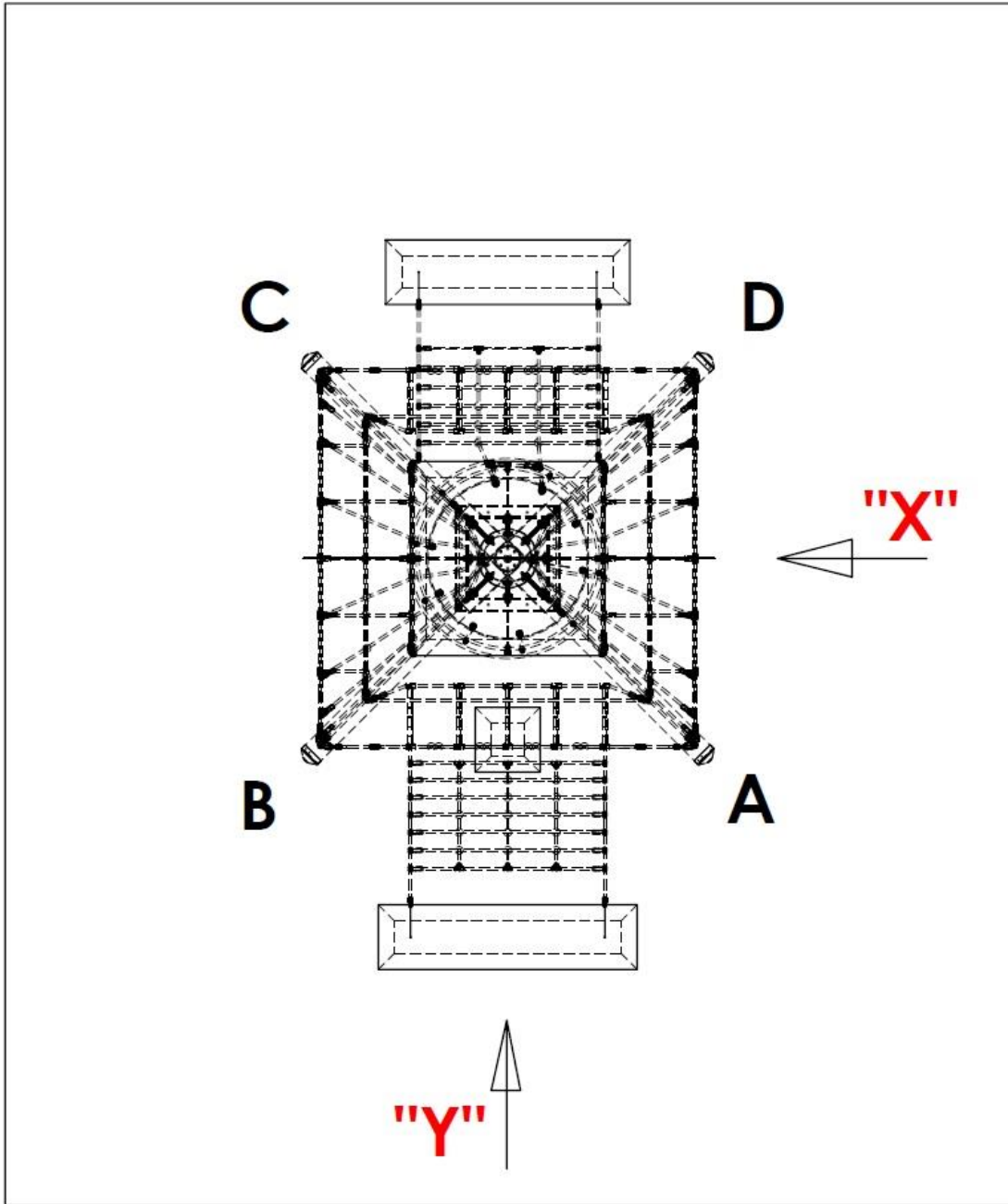

A: „Y“

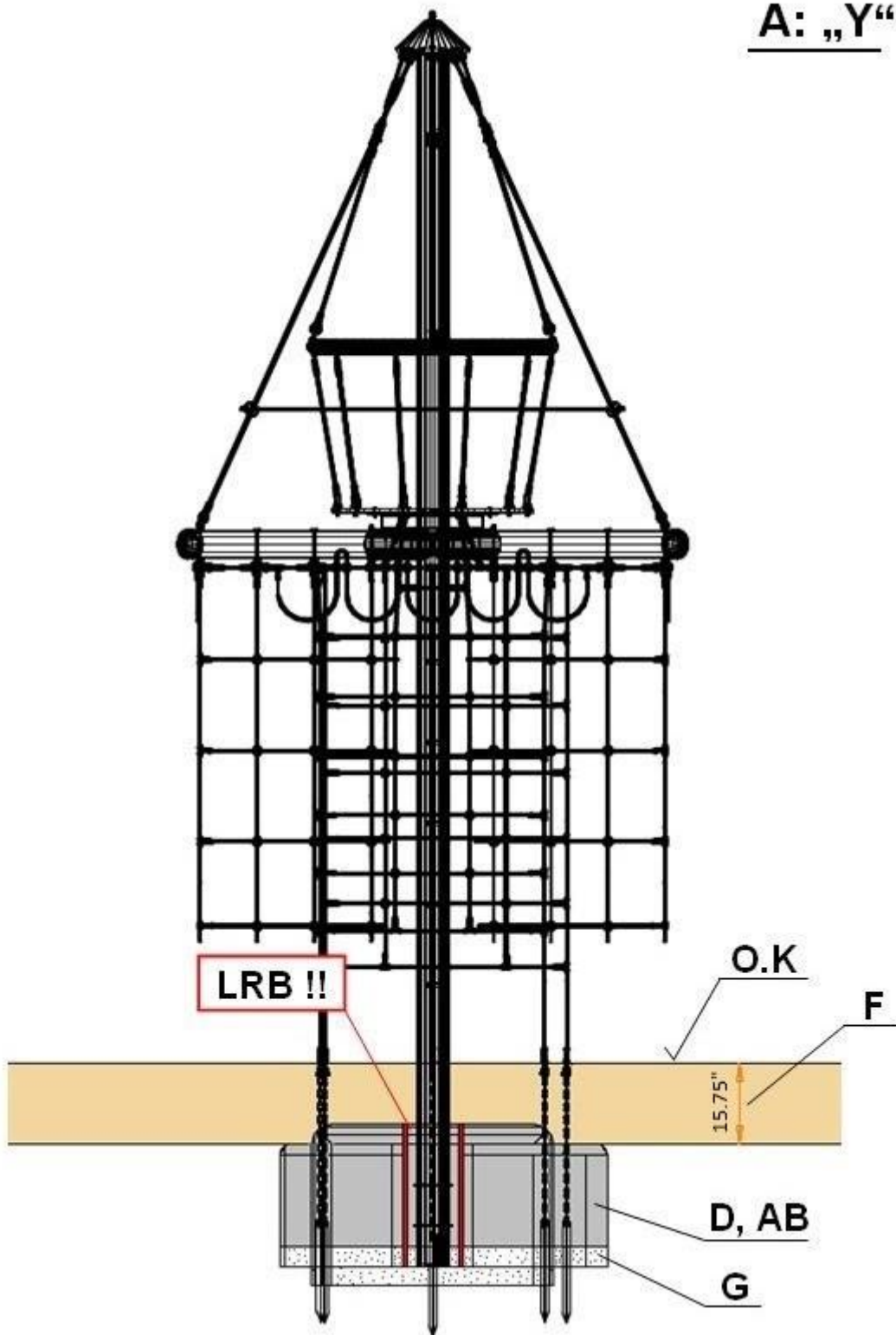

A: „X“

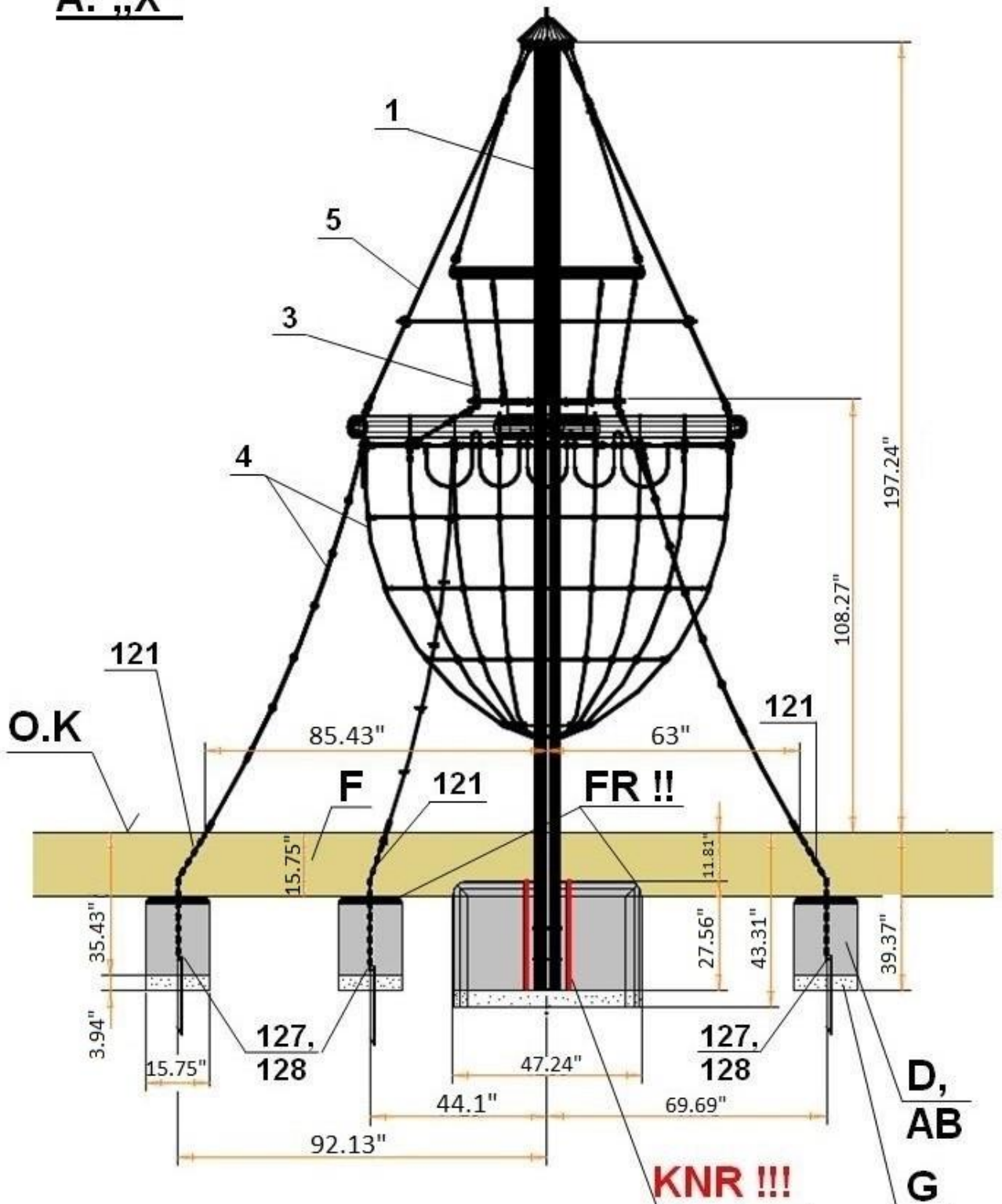

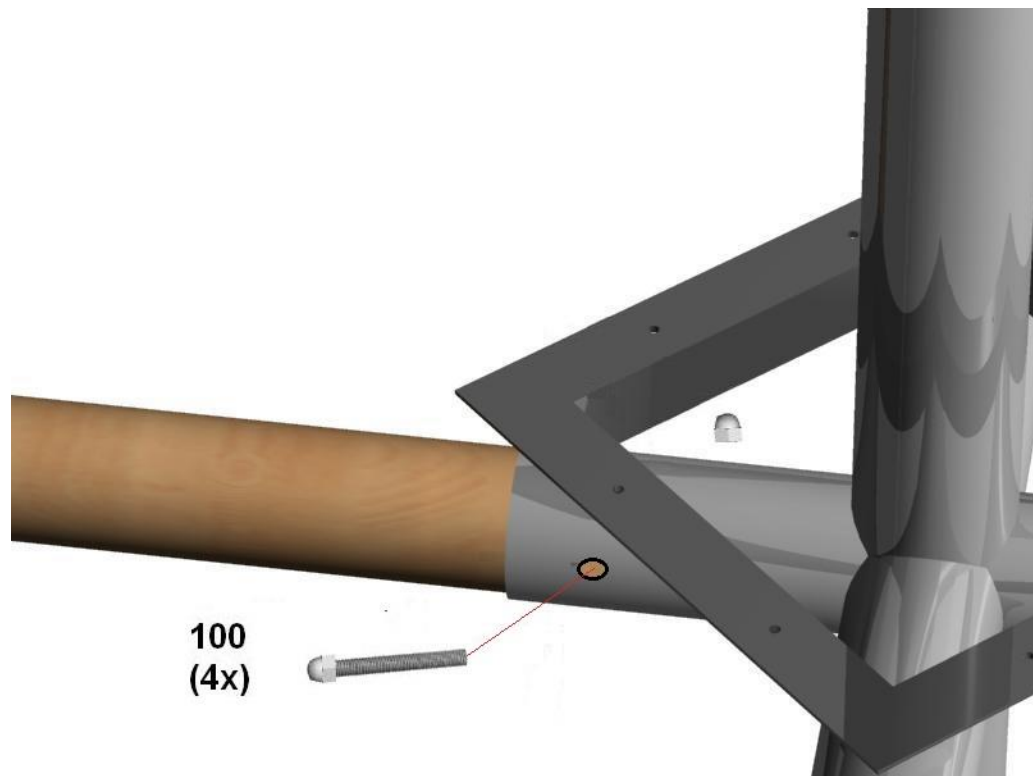
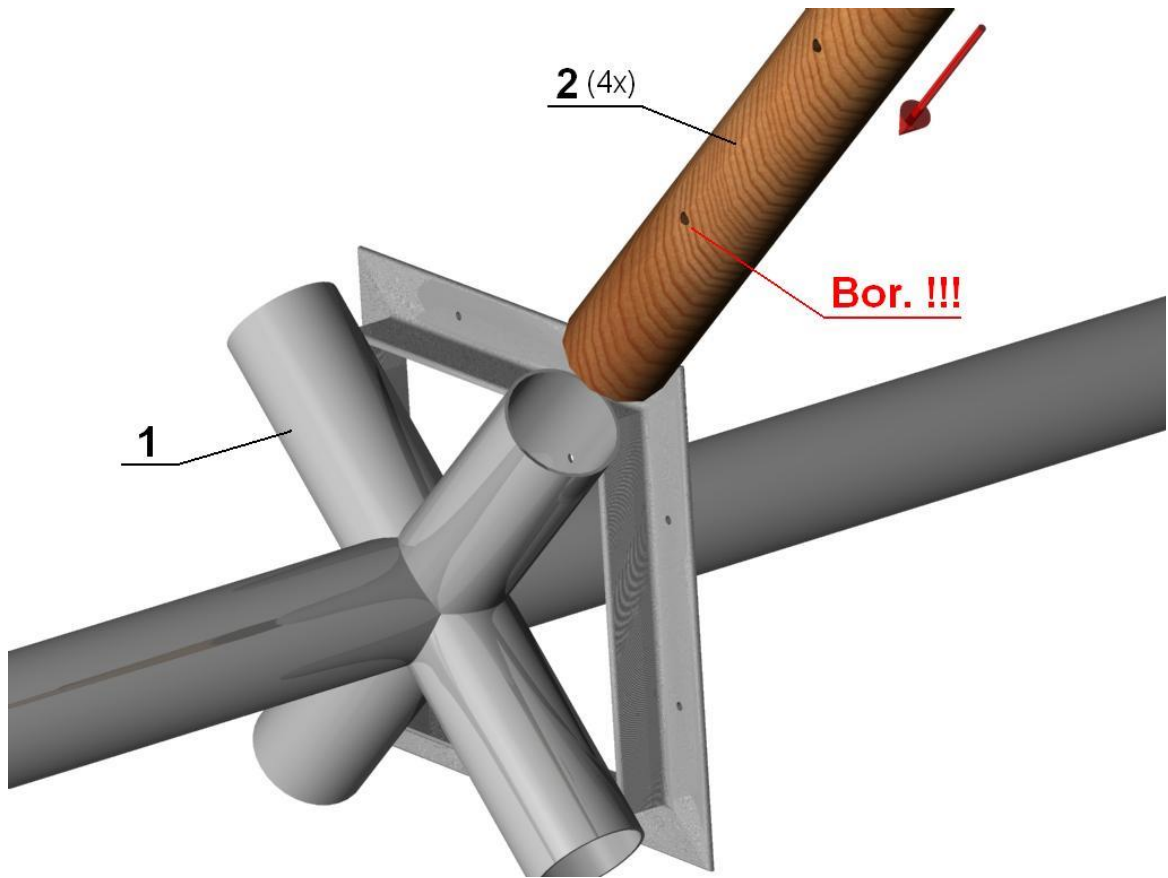

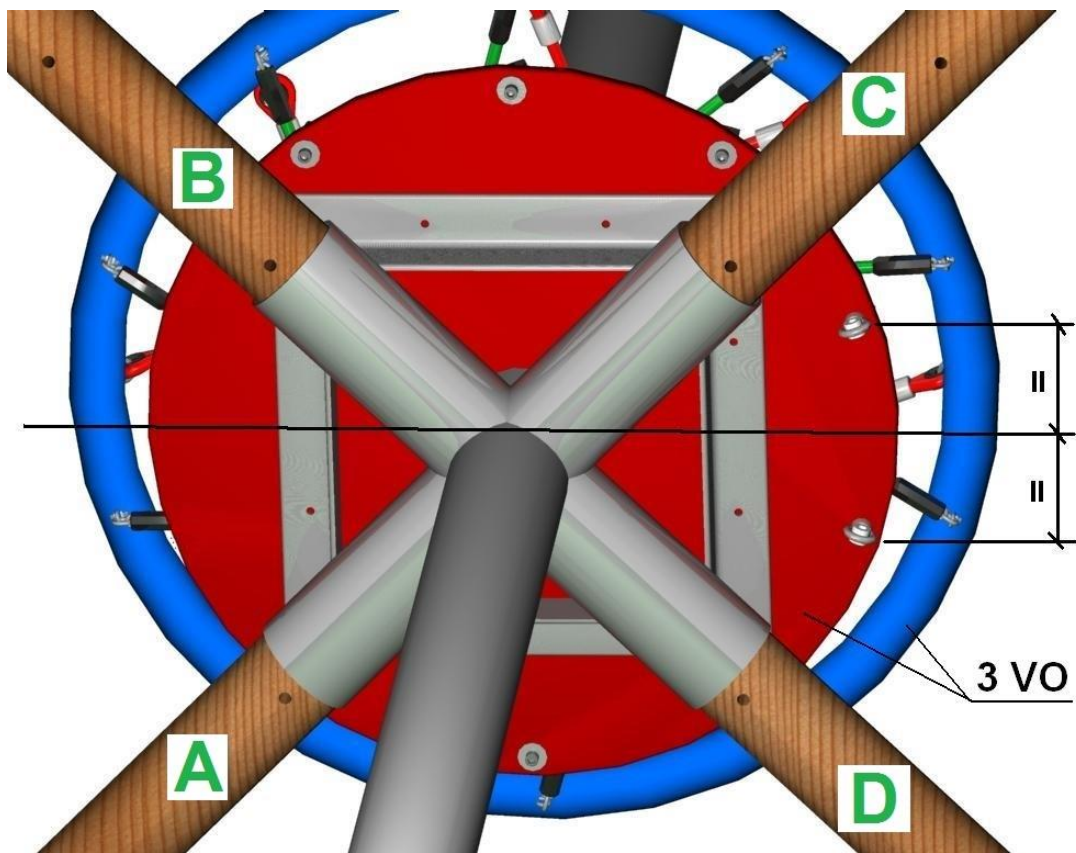
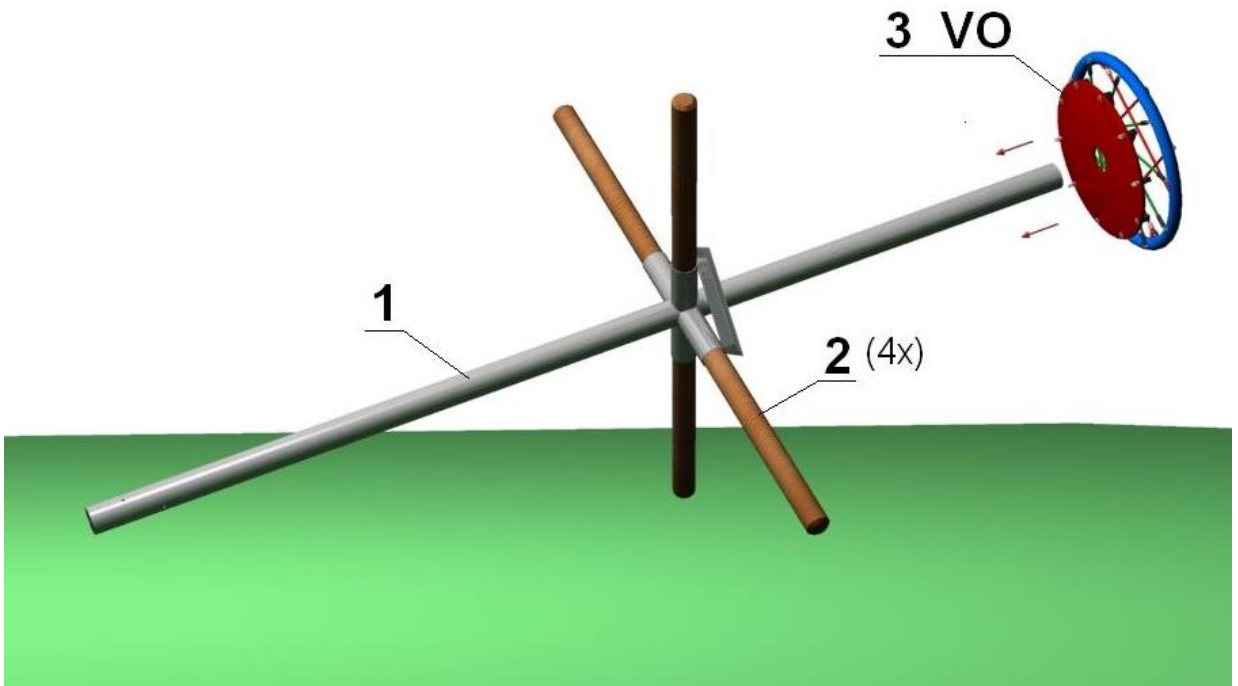

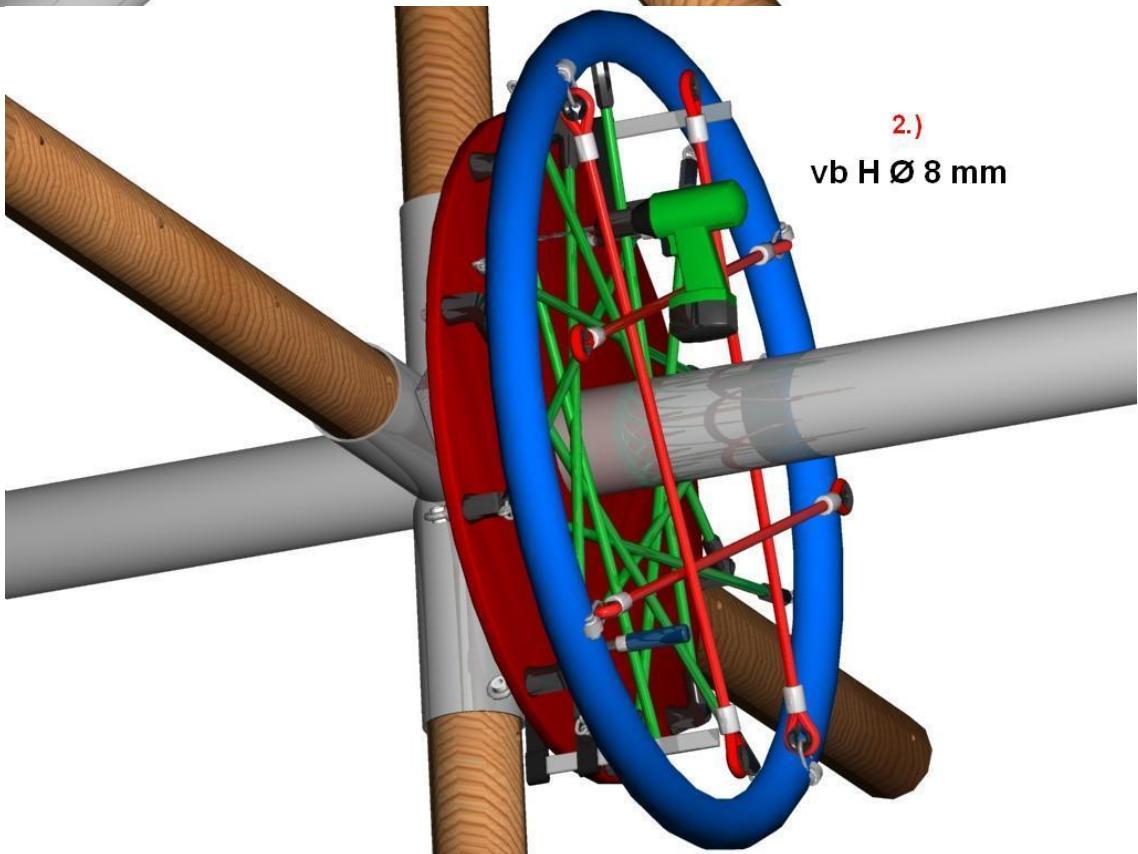
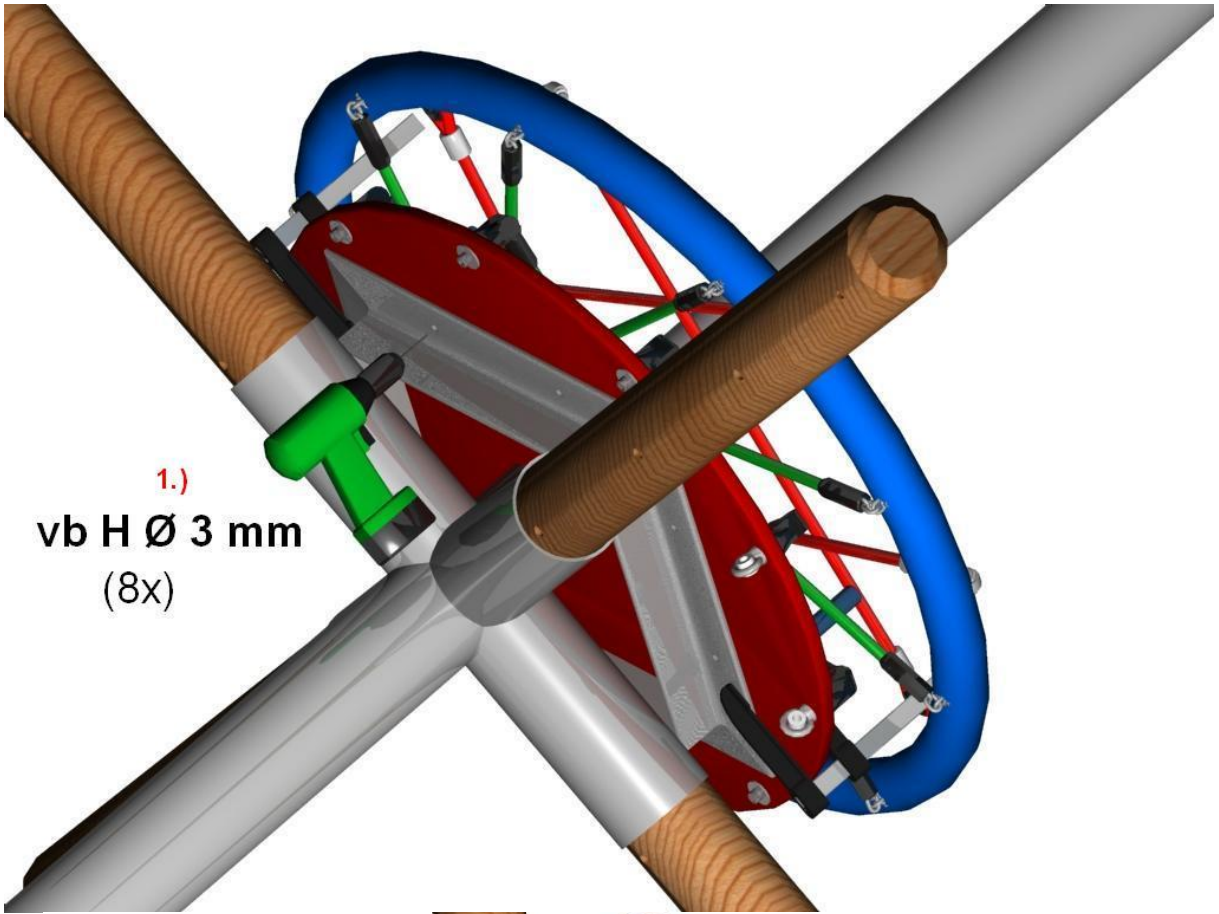

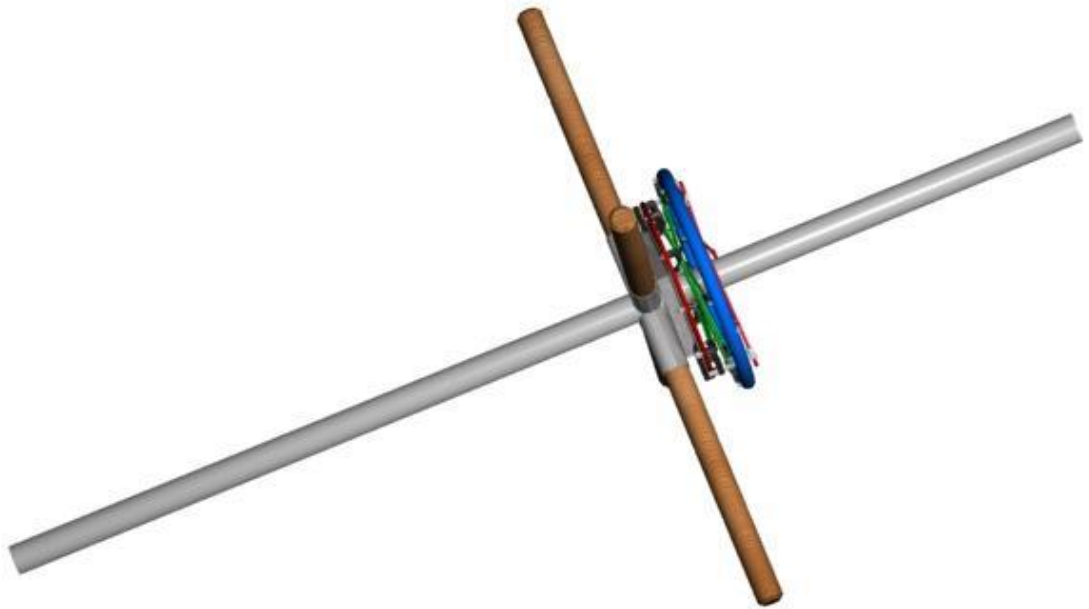
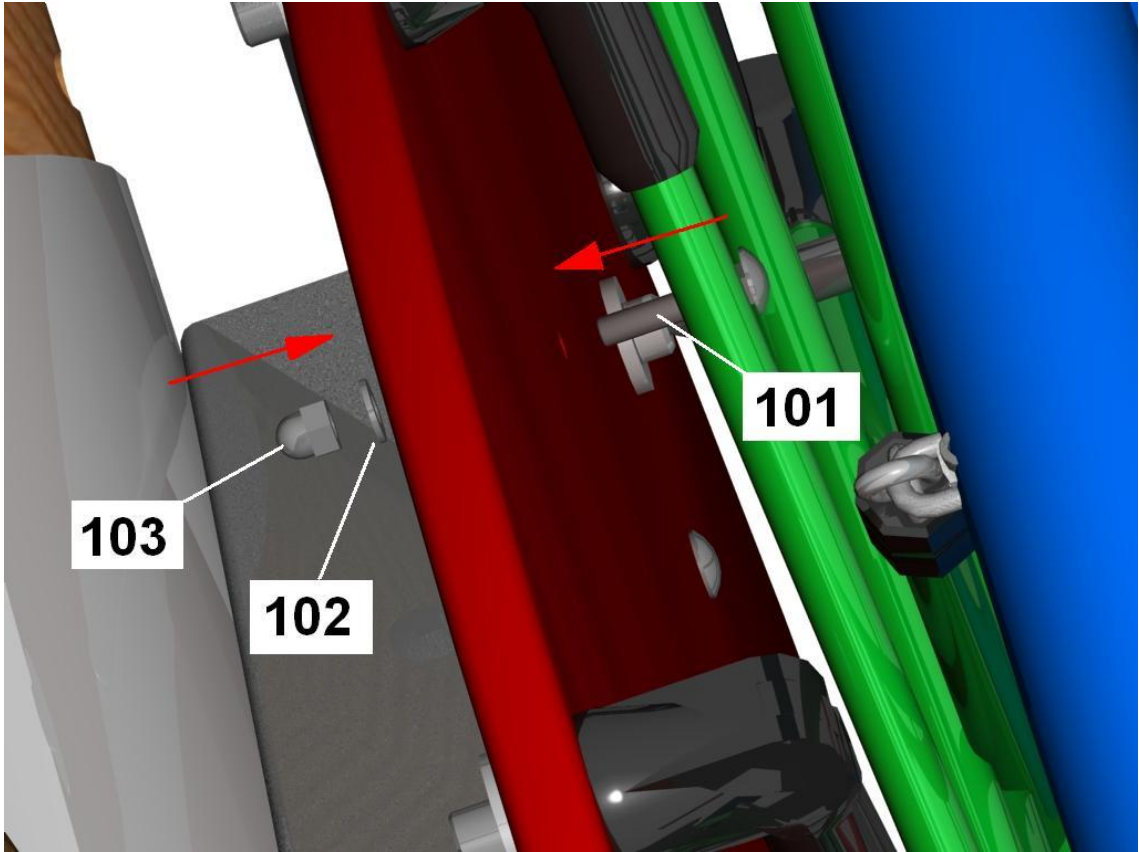



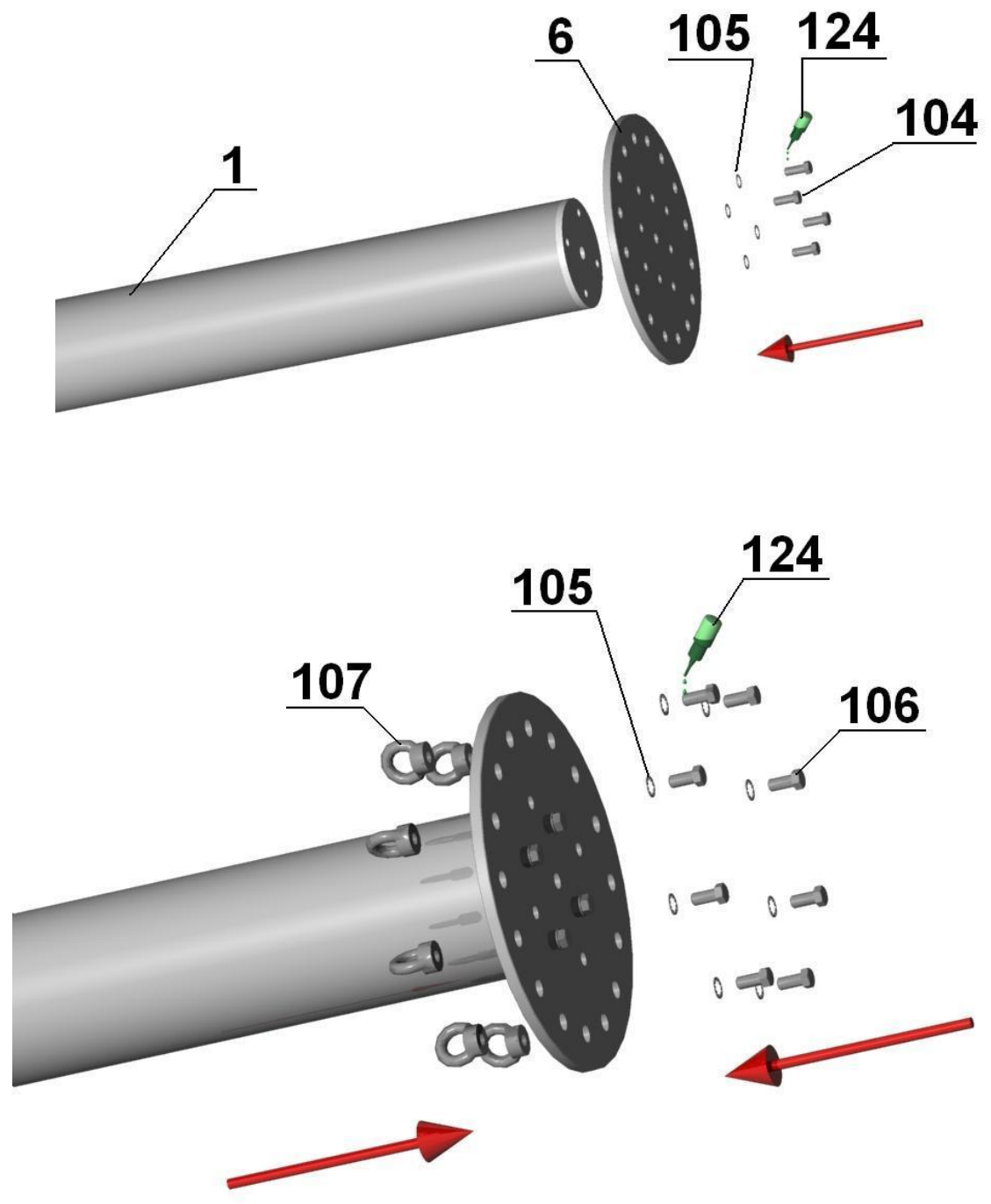

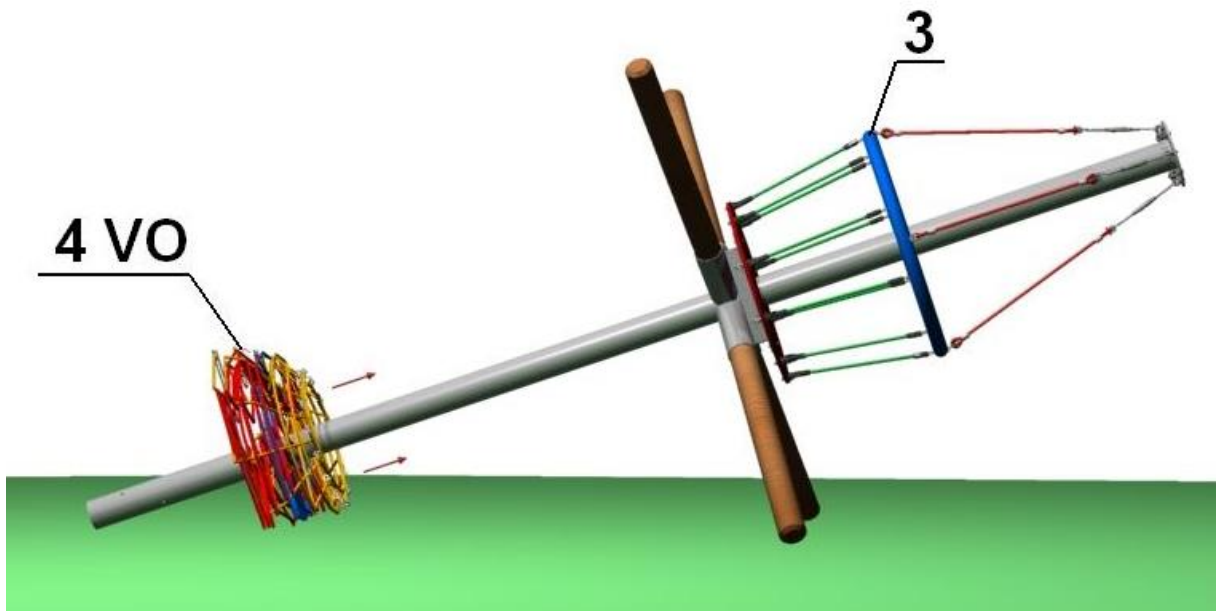
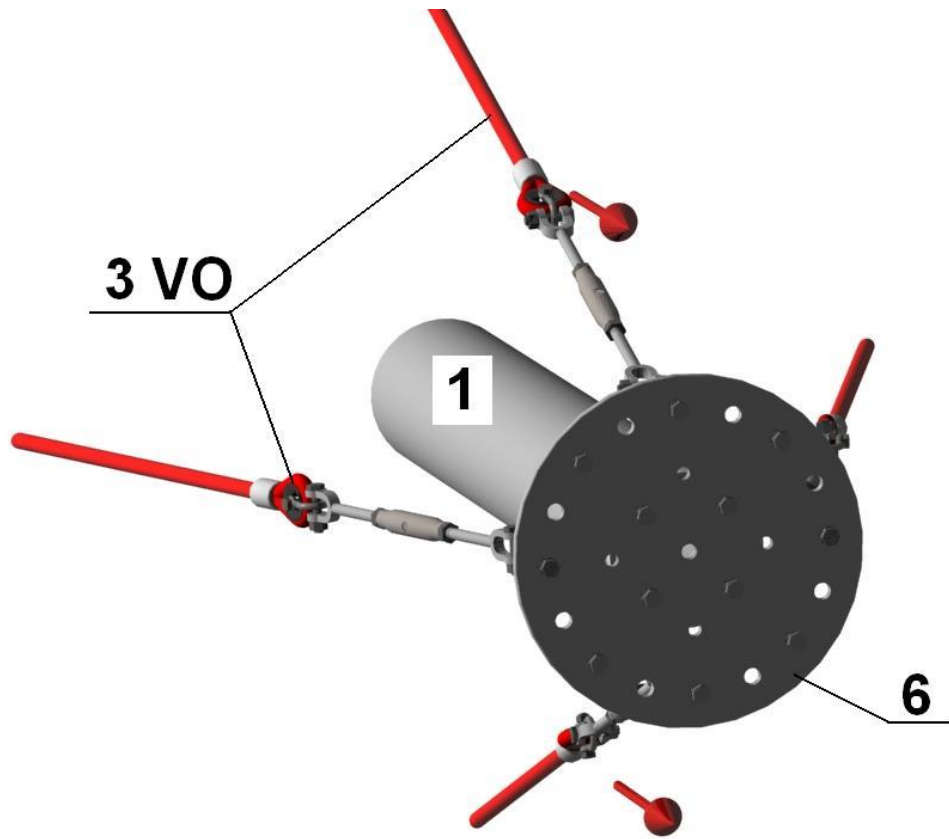

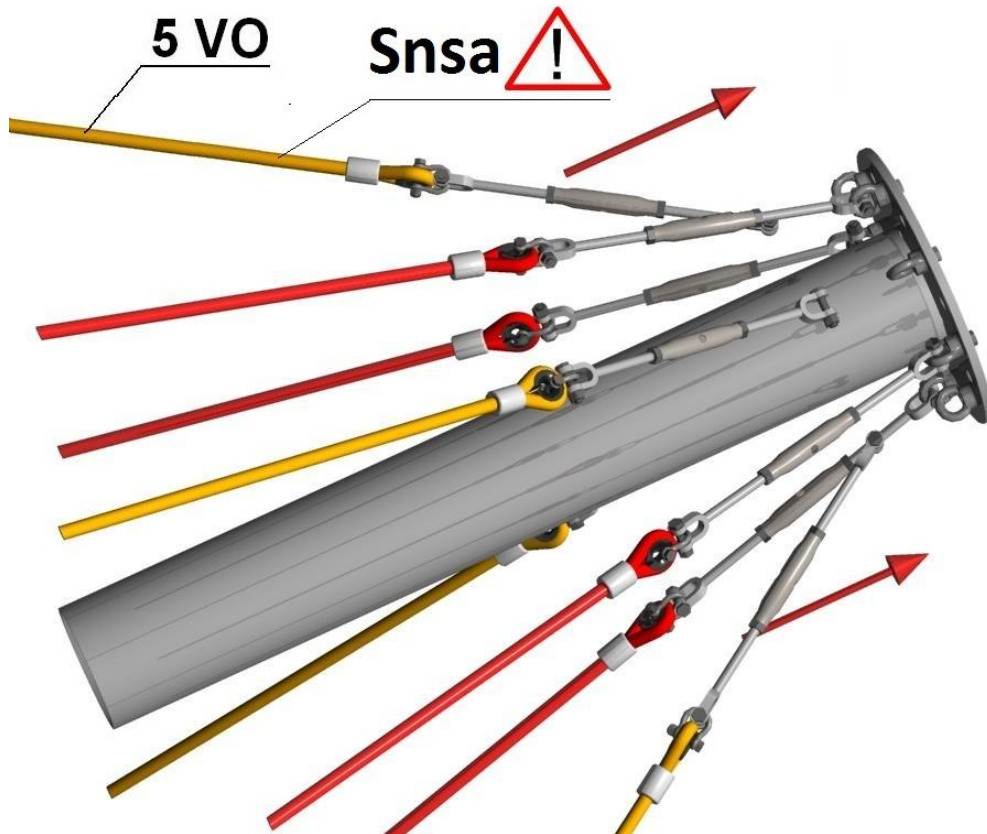
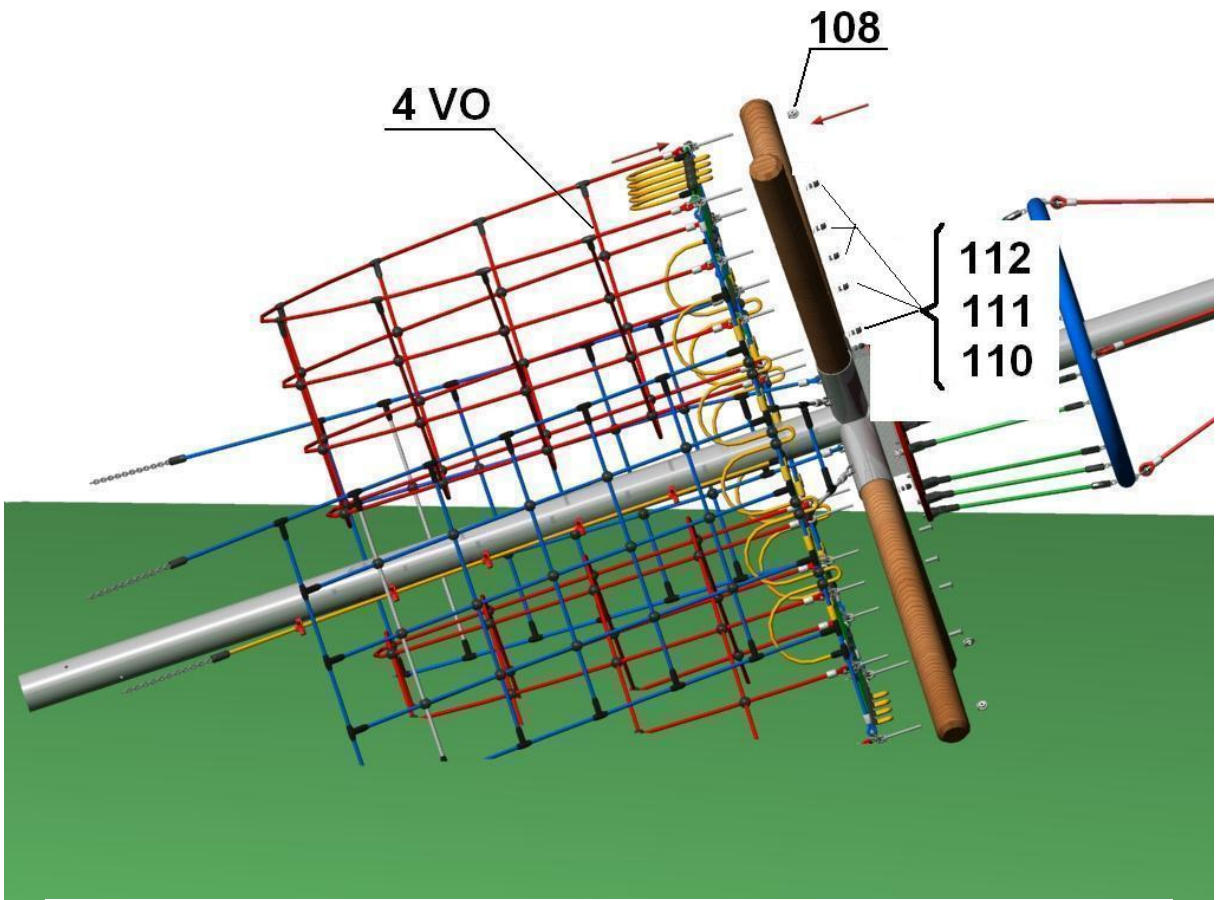

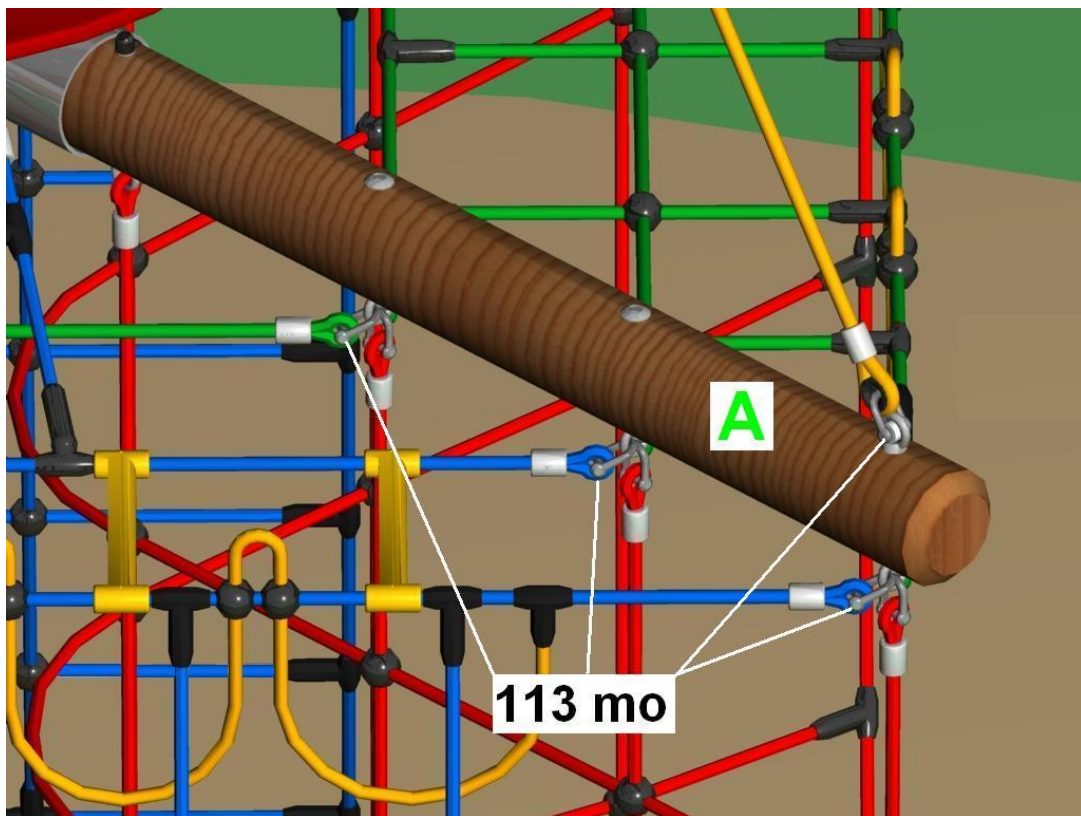
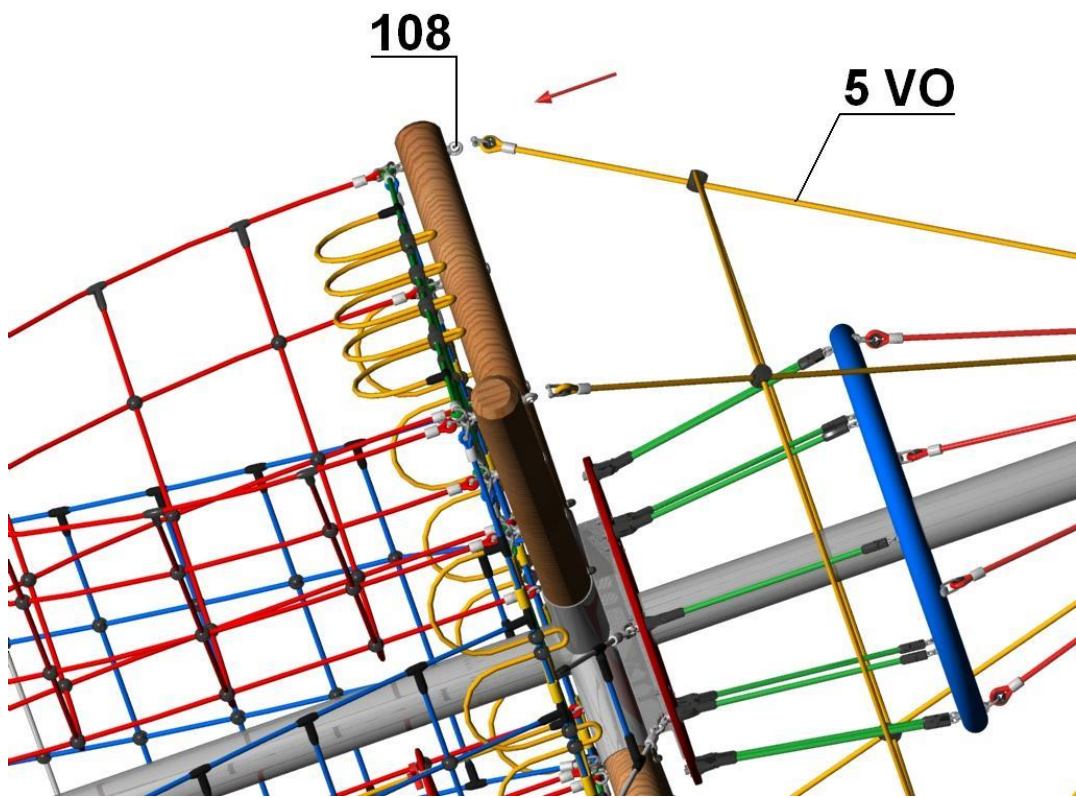

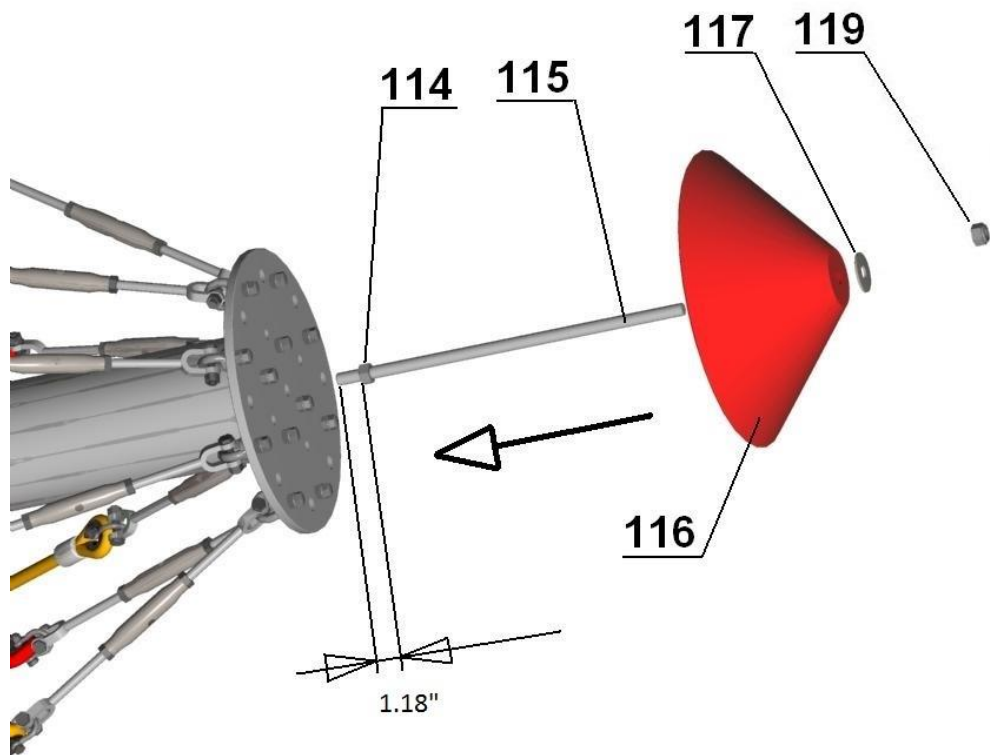

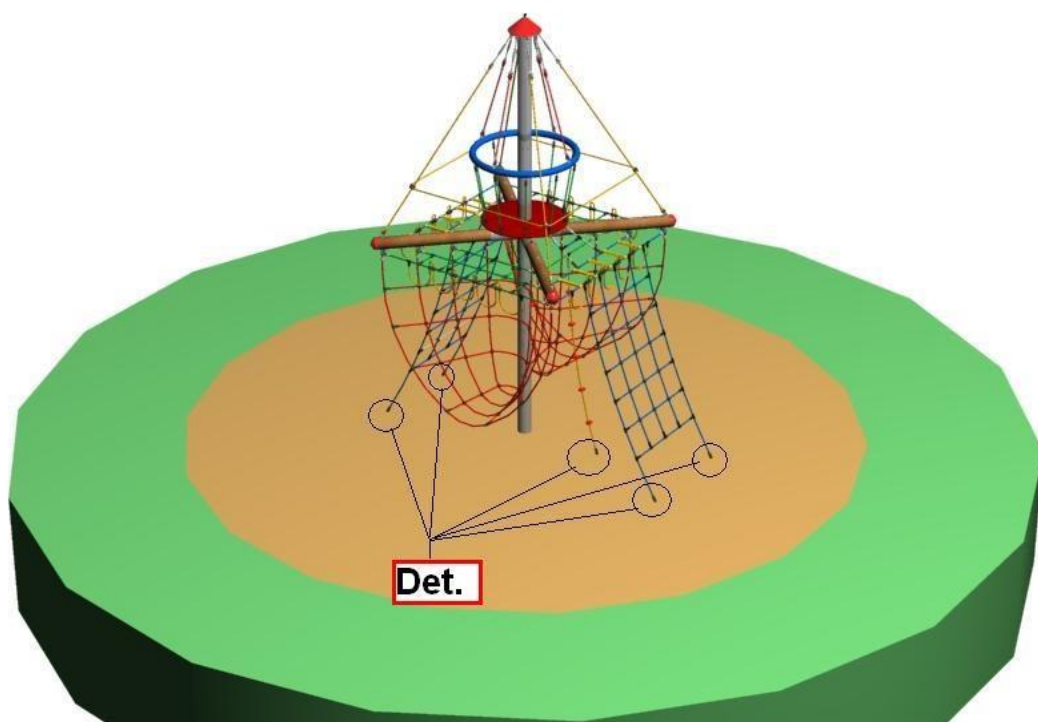
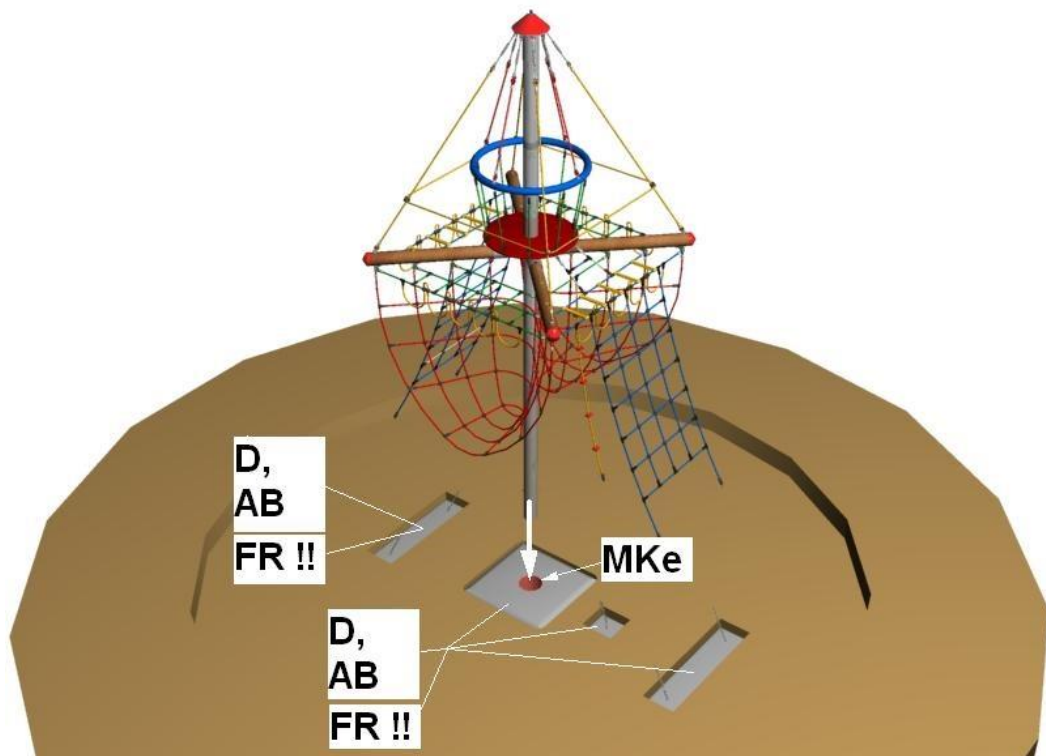

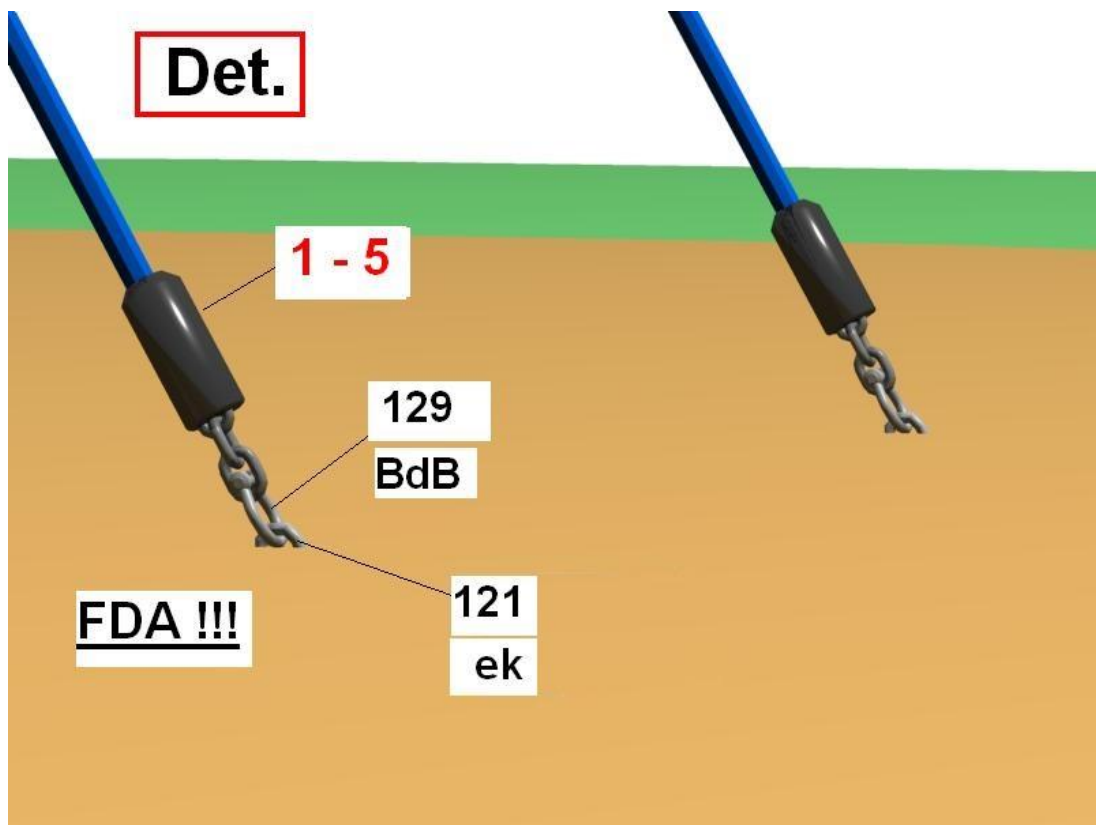
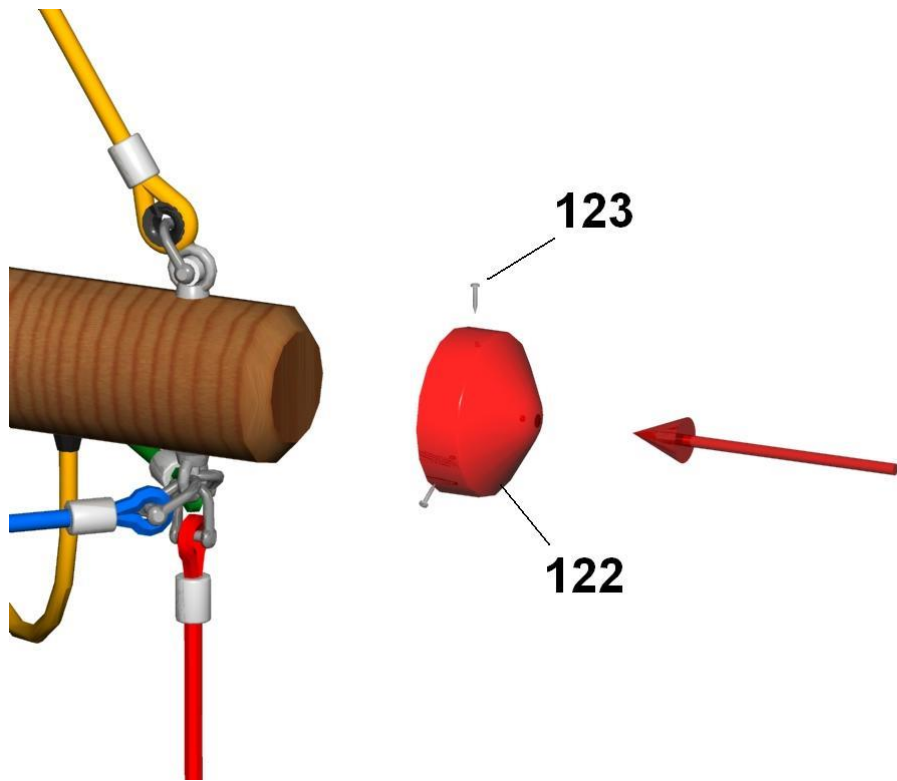

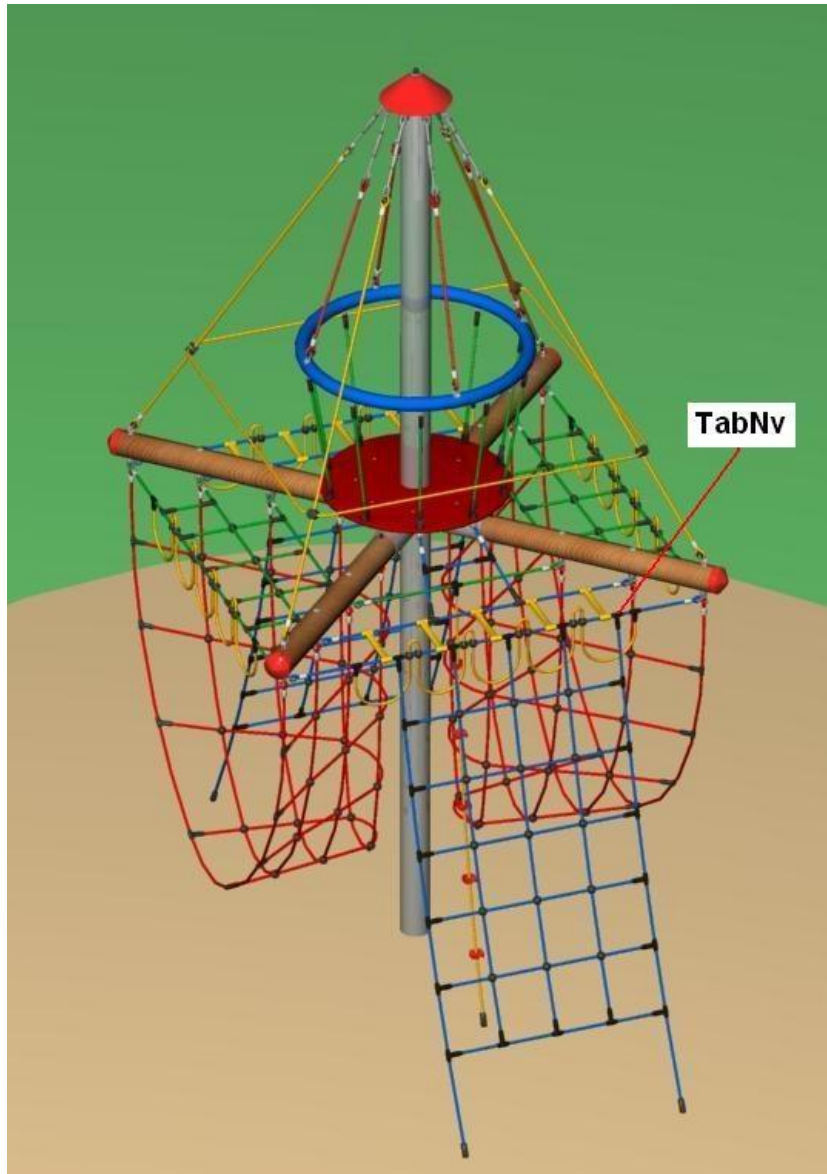



---

	<b>Abbreviations for Pirates Tower</b>
<b>AB</b>	The statutory setting deadlines to be met!
<b>D</b>	Concrete C25/30 (for foundations)
<b>EFB</b>	Concrete reinforcement
<b>G</b>	Drainage layer
<b>F</b>	Fall protection
<b>KNR</b>	Middle foundation pipe
<b>LRB</b>	Fill with Concrete after installation is complete
<b>ML</b>	Mast length above playing level
<b>M.Lot !!</b>	Install post vertically level
<b>P</b>	Post
<b>O.K</b>	Upper edge of playing level
<b>S</b>	View
<b>PS</b>	Safety area
<b>VO</b>	Pre-fitted

**See drawings for details of shortcuts**

---

## 5 Post installation checks

---



If the equipment has not been installed correctly, you must ensure that the public is prevented from using it.

---

### 5.1 Marking filler depth

- Labelling the posts to show the depth of material provided as fall protection (i.e. loose filler).

### 5.2 The equipment has not been installed safely in the following cases:

- Installation of equipment is not complete.
- The protective surface has not been installed yet.
- Appropriate maintenance work cannot guarantee operational safety.

### 5.3 Removal of all assembly aids

- Please make sure that all assembly aids have been removed from the playing area. The equipment must not be approved for use until this check has been carried out.

### 5.4 Information about inspection of the equipment before it is used for the first time

- There are no special inspection requirements to be met before the equipment is used for the first time.

### 5.5 Retighten bolts

- After one week of play, please retighten all bolts again. Later upon respective maintenance.

---

**B Maintenance Instructions**  
**Pirates Tower**  
**Art.4687-20S**

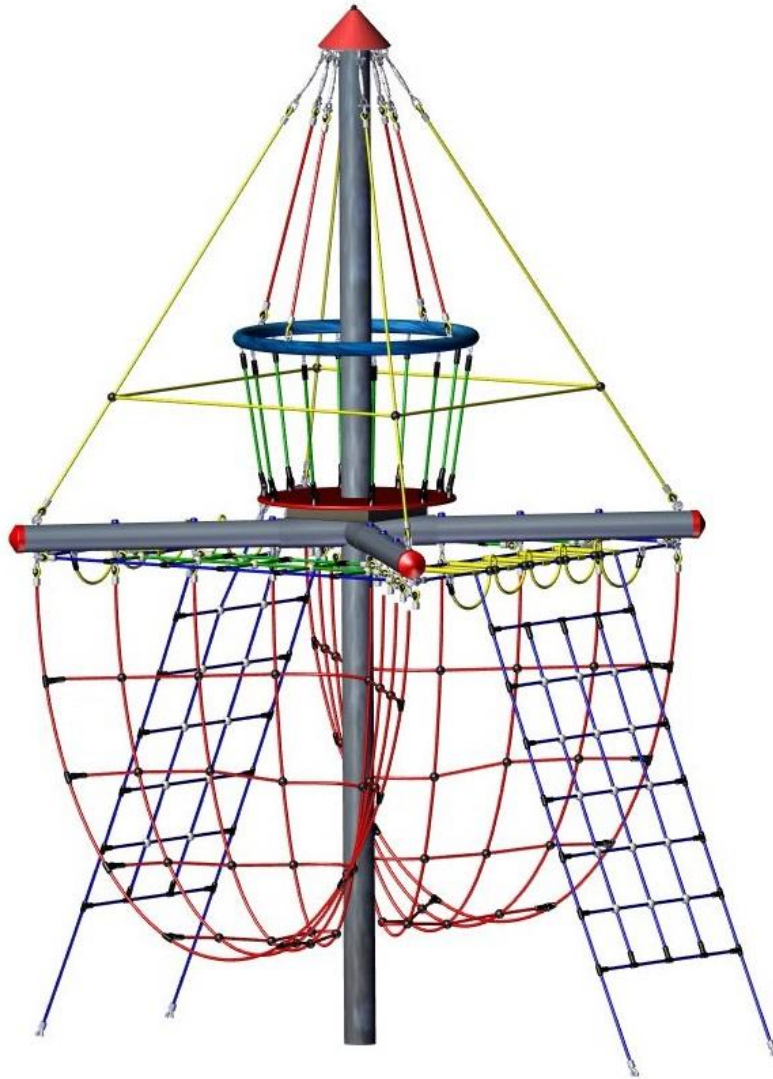

---

**Revision history**

Revision 0 – 2017-02-07

Revision 2 – 2018-11-07 Änderungen n. Angaben v. JF, FH

The first allowed version

Assembly Instructions

All rights reserved

© Copyright 2017 Huck Seiltechnik GmbH

---

## 6 Introduction Maintenance

### 6.1 General informations

This equipment should be installed, inspected, maintained and operated in accordance with ASTM F1487-17 guidelines.



**Please note:** Providing any necessary repairs are carried out, a piece of play equipment that is inspected regularly cannot become so damaged that it is dangerous to the user.

---

Any spare parts which may be required can be obtained directly from your supplier.



This equipment should only be assembled, maintained and repaired by **persons with the necessary expertise.**  
**A copy of the inspection record should be given to the operator, who must confirm receipt.**

---

**These maintenance instructions are based on the standard  
ASTM F1487-17**

---

## **7 General maintenance information**

### **7.1 Maintenance intervals**

Maintenance intervals are based on average use. Please note that more frequent inspections and/or maintenance are required if the play equipment is subject to intensive use.

### **7.2 Inspection frequency**

The frequency of inspections must be based on actual use. Factors that affect frequency include vandalism, location (e.g. coastal proximity), air pollution and the age of the equipment.

### **7.3 Maintenance products and procedures**

All nuts and bolts are hot-dip galvanised or stainless steel. One of the characteristics of stainless steel is that uncontrolled cold welding/Thread grinding may occur when the nuts are tightened. To prevent this, it is necessary to spray the nuts and bolts with Teflon spray or another similar lubricant.

### **7.4 Spare parts**

All spare parts must conform to the manufacturer's specifications.

### **7.5 Identifying spare parts**

All spare parts are listed in the parts list. The parts list follows the installation requirements.

### **7.6 Special instructions for the disposal of individual equipment components**

No special instructions are necessary.

### **7.7 Actions to be taken during the break-in period**

No later than 2 weeks after assembly, all screwed connections should be checked and tightened if necessary. Ropes connected to foundations **must** be retensioned

### **7.8 Maintenance of protective surfaces**

Surfaces providing fall protection must also be maintained regularly. It is particularly important to maintain the correct level of loose surface material and add more if necessary (refer to ASTM F1292 and ASTM F2223).

---

## 7.9 Defects

---



**Attention**

Damages must be repaired as soon as they are detected. If serious defects that affect the safeness cannot be repaired straight away, the equipment then must be closed with immediate effect to prevent further use.

---

## 7.10 Loose screws

---



**Attention**

Loose screws always cause quality problems and put safety at risk. Therefore, loose screws should always be tightened and checks carried out to ensure that there are no missing screws.

---

## 7.11 Preventing equipment use

Use of the equipment should be prevented in the event of incomplete installation, disassembly, maintenance, repairs and defects.

## 7.12 Claims/liability for defects (steel posts)

Steel posts and footings are covered by our guarantee if regular maintenance is carried out and recorded in writing.

Our general terms and conditions apply. Maintenance of steel posts first take place after 3 years. The steel posts must be excavated down to the concrete foundations and checked for corrosion. Zinc paint should be applied to any corroded areas and scratches. Check ropes for abrasion, replace ropes where coating is worn down the steel core.

---

## 8 Maintenance timetable

### 8.1.1 Maintenance interval

We strongly advise you to carry out inspections and maintenance work within the specified periods as use of the equipment, the weather and malicious vandalism cause wear and tear that compromises the safety and function of the equipment.

### 8.1.2 Maintenance intervals in the event of intensive use

Please note that more frequent inspections and/or maintenance are required if the play equipment is subject to intensive use.

### 8.1.3 Defects that compromise safety



In the event of defect that compromises safety, quick action must be taken. This may involve repairing it immediately or shutting down and dismantling the equipment.

### 8.1.4 Defects that compromise function



Defects that compromise function should also be repaired immediately. Such defects lower the value of the equipment to the user and encourage malicious vandalism, which may render the equipment less safe. Any damage should also be repaired immediately.

---



---

## 9 Regular maintenance

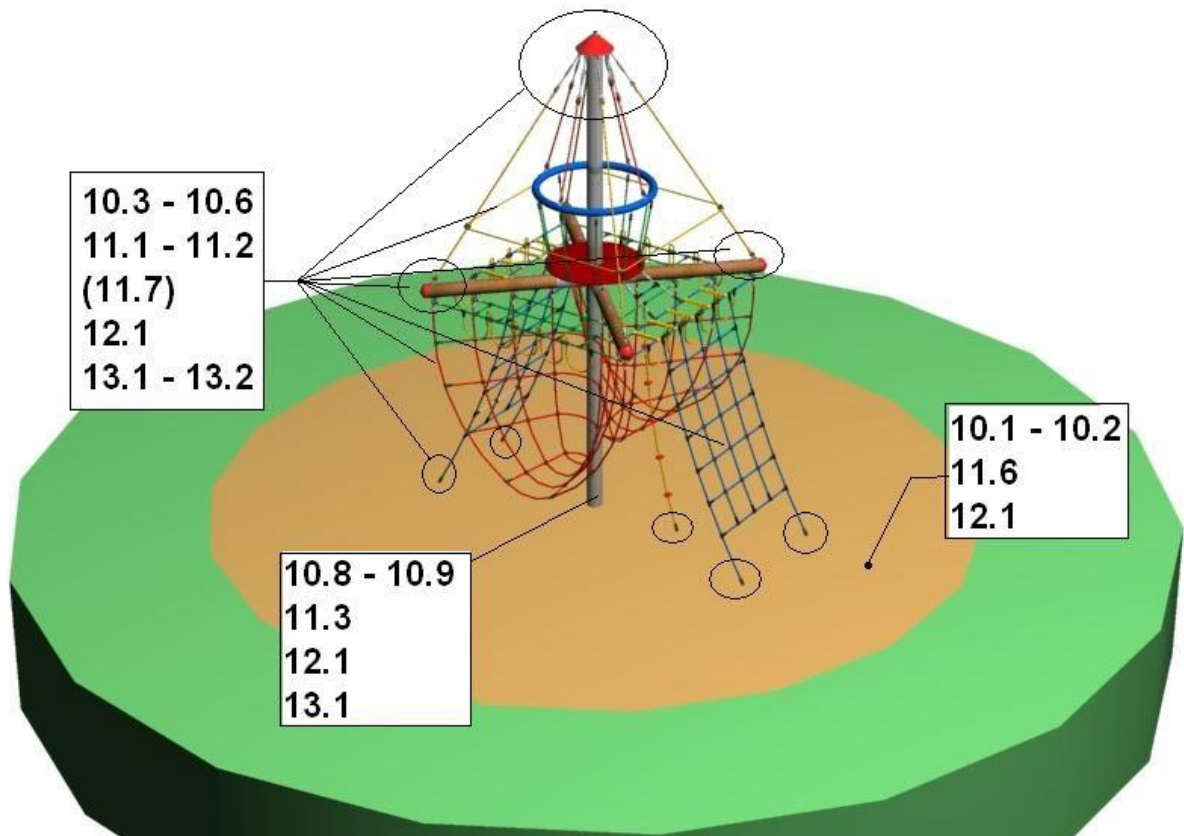

## 10 Monthly maintenance

- 10.1 Check the spaces between the equipment and the ground (clearance and height of fall).
- 10.2 Check the ground surface of fall protection for hard objects and loose foundations.
- 10.3 Check all connecting elements and fittings for wear and tear and tighten if necessary. Repair or replace damaged or missing parts.
- 10.4 Check that moving metal parts (joints, springs, etc.) move smoothly and are not worn. Repair or replace if necessary. It is not necessary to lubricate joints as we only use maintenance-free metal roller bearings.
- 10.5 Check all attachments such as chains, ropes, nets, etc. for damage and tension, repair or replace if necessary.

- 
- 10.6 Check rubber parts, sleeves, etc. for wear and tear or damage and repair or replace if necessary.**
  - 10.7 If necessary, remove excess padding material from the post footings due to danger of rotting.**
  - 10.8 Check the surface of wooden parts for damage caused by the weather or external influences and mold. Repair or replace if necessary.**
  - 10.9 Check the surface of plastic and metal parts, e.g. slides, for damage and replace if necessary.**

## **11 Quarterly maintenance**

- 11.1 Detailed inspection of the operation and stability of the equipment paying particular attention to any wear and tear.**
- 11.2 Tighten all forms of attachment.**
- 11.3 Repaint and retreat surfaces if necessary.**
- 11.4 Maintenance of fall protection surfaces.**
- 11.5 Lubrication of joints.**
- 11.6 Check height of fall protection material and fill up with filler if necessary. If the posts are labelled, fill up to the mark.**
- 11.7 Retension the tension ropes after a period of 3 months. Afterwards please check in equal intervals.**
- 11.8 Retighten all bolts.**

## **12 Half yearly maintenance**

- 12.1 The stability of supporting posts, supports, foundations etc. has to be checked. The safety level of the entire system has to be checked after repairs have been carried out or additional system components have been installed or replaced.**



## **Annual Maintenance**

---

### **13 Annual maintenance**

- 13.1 Ascertaining that the equipment, foundations and surfaces are safe for operation.**
  - 13.2 In particular, the equipment should be checked for decay and corrosion. It may be necessary to dig out or excavate certain components in order to do so. Zinc paint should be applied to corroded areas and scratches.**
- 
-

**14 Maintenance printout**

Name of item: Pirates Tower \_\_\_\_\_ / Art. No. 4687-20S \_\_\_\_\_

Location: \_\_\_\_\_

Customer or operator: \_\_\_\_\_  
 (Town, Town council, Kindergarten)

Date of inspection	Inspector	O.K.	Accessible	Barriered	Defects	Repaired by	Date

**Please copy and return once a year after main inspection has been carried out to the owner/ operator**

**by Telefax**

**Place the confirmation form in the play equipment files.**



## 15 Hand over document

---



After the installation of the equipment, pass the installation and maintenance documents to the operator. The operator has to receive the hand over documents. The complete filled out and signed Hand over document should be copied and sent to the supplier.

---

Art.-No.: 4687-20S

Type of item: Pirates Tower

Serial number: \_\_\_\_\_

**Customer or operator (Town, Town council, Kindergarten, etc.):**

\_\_\_\_\_  
\_\_\_\_\_

Competent person in charge:

\_\_\_\_\_  
\_\_\_\_\_

**Installation company (address):**

\_\_\_\_\_  
\_\_\_\_\_

Responsible assistant (assembler):

\_\_\_\_\_  
\_\_\_\_\_

Received the complete assembly instructions, maintenance instructions and maintenance printout.

\_\_\_\_\_  
\_\_\_\_\_

(Signature of operator)      (Signature of installation company)  
(Stamp)

Date: \_\_\_\_\_