

511-114 SIT-UP STATION

Page 1 of 1
Rev 4/7/03

* IMPORTANT *

PLEASE RETAIN THIS INSTRUCTION SHEET IN YOUR FILES. IT CONTAINS IMPORTANT REPLACEMENT PARTS INFORMATION. ALL EQUIPMENT SHOULD BE INSTALLED IN ACCORDANCE WITH THESE INSTRUCTIONS.

IT IS IMPORTANT TO USE AND MAINTAIN ALL PUBLIC PLAYGROUND EQUIPMENT PROPERLY. PLAYGROUND EQUIPMENT WHICH IS IMPROPERLY MAINTAINED CAN CAUSE SERIOUS INJURY. PERIODICAL INSPECTIONS, MAINTENANCE, REPAIR AND/OR REPLACEMENT OF DAMAGED PARTS IS NECESSARY FOR SAFE OPERATION OF EQUIPMENT AND SAFETY OF USERS. RESILIENT SURFACING SHOULD BE USED UNDER ALL PLAYGROUND EQUIPMENT. APPROPRIATE PUBLICATIONS, AVAILABLE AT NO CHARGE, FROM THE CONSUMER PRODUCT SAFETY COMMISSION, INCLUDE "A HANDBOOK FOR PUBLIC PLAYGROUND SAFETY." YOU CAN RECEIVE YOUR FREE COPY BY CALLING 1-301-504-7908.

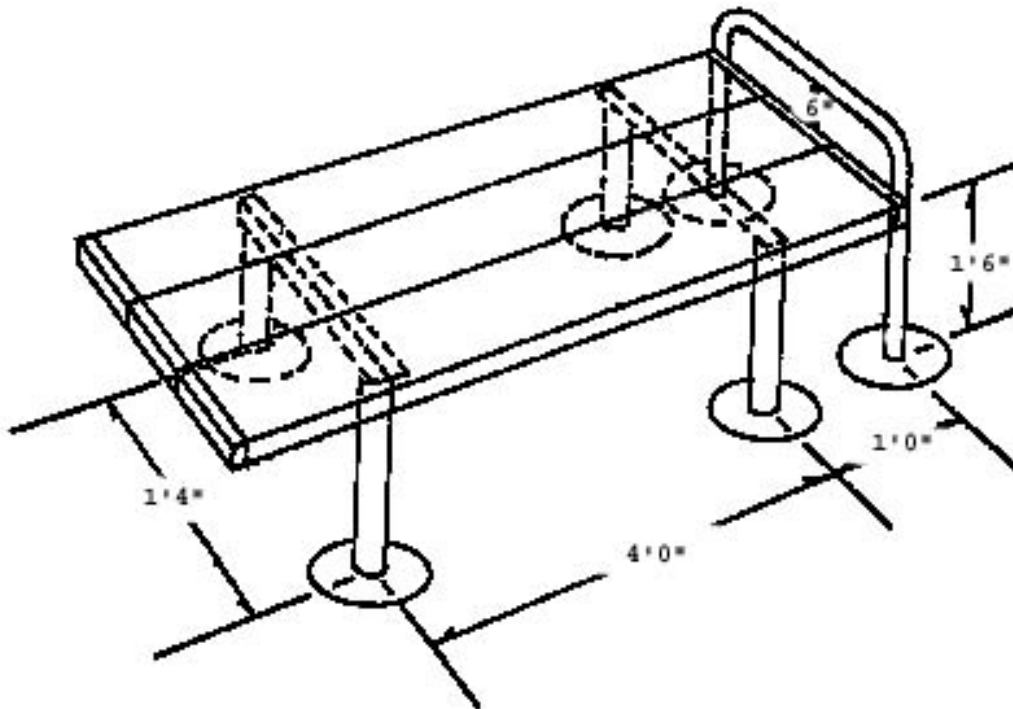

PACKING LIST

1 CTN	- 1	Hardware	Bag
1 BDL	- 3	603-906	6' Alum Board
1 BDL	- 3	603-505	Angles
1 BDL	- 4	503-216	Legs
1 PIPE	- 1	513-615	Toe Bar

HARDWARE BAG

12	-	605-506	Clips
4	-	116-512	5/16" x 3" Hex Hd Bolt
12	-	126-504	5/16" x 1" Carriage Bolt
16	-	316-501	5/16" Flat Washer
16	-	216-501	5/16" Hex Nut
1	-	805-532	Warning Label
1	-	805-534	SportsPlay Label
1	-		Maintenance Checklist

1 CTN

3 BDL

1 PIPE

5 TOTAL PCS

WT 80#

CLASS 70

511-114 SIT-UP STATION

GENERAL USE/FALL ZONE & FOOTING RECOMMENDATIONS

STATIONARY & PORTABLE EQUIPMENT - USE/FALL ZONES SHOULD EXTEND A MINIMUM OF 6 FEET IN ALL DIRECTIONS FROM THE PERIMETER OF THE EQUIPMENT GROUND SPACE. THIS AREA SHOULD BE COVERED WITH THE REQUIRED AMOUNT OF RESILIENT SAFETY SURFACING MATERIAL. FOR SOME EQUIPMENT - USE/FALL ZONES CAN OVERLAP. SEE CONSUMER PRODUCT SAFETY COMMISSION GUIDELINES. DIAMETER & DEPTH OF FOOTING ILLUSTRATED ARE SATISFACTORY IN MOST APPLICATIONS FOR PIPE SIZES UP TO 2 3/8" DIAMETER. VARYING SOIL & CLIMATIC CONDITIONS MAY REQUIRE DEEPER & HEAVIER FOOTINGS IN SOME AREAS. CHECK LOCAL BUILDING CODES.

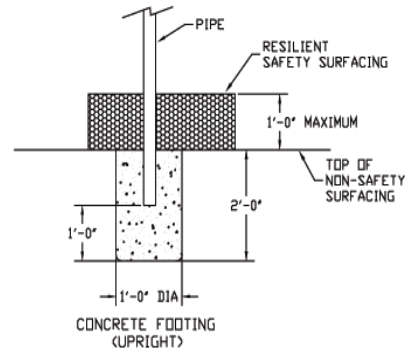
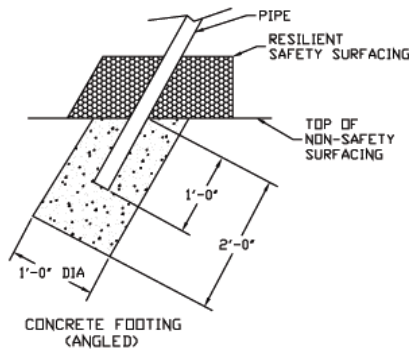

* If resilient surfacing is to be less than 12", then additional pipe should be put in concrete to maintain proper finish grade for equipment.

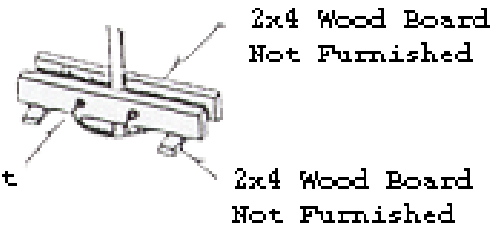
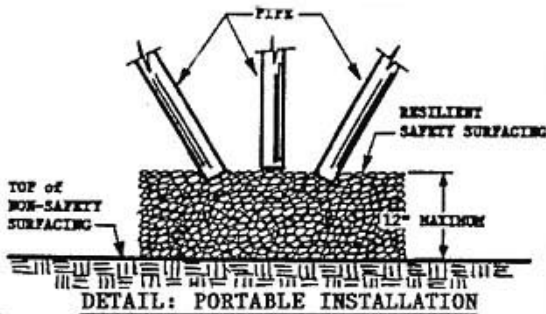

Suggested Bracing Method

USE AREA & FOOTING LAYOUT:

USE AREA:
14' X 18'

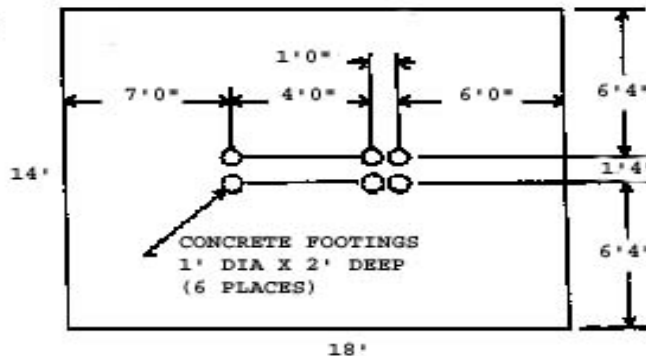

511-114 SIT-UP STATION

Page 3 of 3
Rev 4/7/03

GENERAL ASSEMBLY INSTRUCTIONS:

Check all the parts and hardware with the packing list to be sure you have received everything needed to assemble this product. CONTACT YOUR LOCAL DISTRIBUTOR WITH NOTIFICATION OF ANY MISSING OR DAMAGED PARTS. Contact must be made within ten days of receipt of your order.

Only hand-tighten nuts & bolts on initial assembly. Final tightening should be done **EVENLY** after final assembly when unit has been plumbed & leveled.

After assembly is complete, **ANY ENDS OF BOLTS PROTRUDING BEYOND NUTS SHOULD BE CUT OFF AND/OR PEENED OVER TO REMOVE ANY SHARP EDGES.** Go over entire unit to file smooth any sharp edges or projections that may have been caused by rough handling in shipping or installation. T-Clamps are designed for both one and two bolt connections. In many situations only one bolt is required. See specific assembly instructions.

On products with platforms install 1 - 2 degrees off level to facilitate water drainage.

GENERAL MAINTENANCE INSTRUCTIONS:

Check **MONTHLY** for loose bolts, damaged or broken parts. Tighten and/or replace immediately.

SPECIFIC ASSEMBLY INSTRUCTIONS:

STEP #1: Mark & dig footing holes per SKETCH on PAGE #2.

STEP #2 &
#3:

STEP #2: On the ground, assemble aluminum boards to angles.

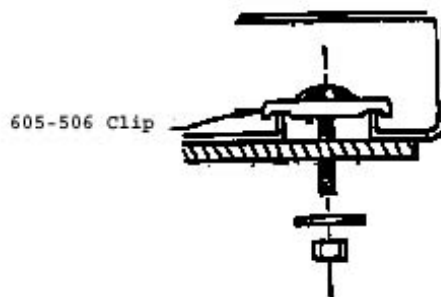

STEP #3: Then attach Board assy to Legs

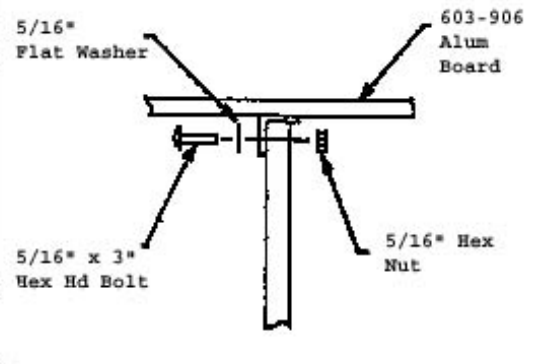

STEP #4: Stand up & brace in footing holes. Length of pipe below intended level of resilient surfacing should be 24". Two long braces holding 2 legs each are recommended.

STEP #5: Plumb & level entire unit. Pour Concrete. Tighten all nuts & bolts so that lock washers are flat. Wait 48 hours before removing braces, installing Resilient Surfacing & using equipment.

STEP #6: Attach Warning Label and Manufacturer's Identification Label to a clean surface. The Labels should be attached in a location where they are clearly visible and legible and away from normal hand and foot placement areas. The Labels must be replaced if they become illegible, destroyed or removed. Contact your distributor for replacement Labels.