



6' Standard Bench with Back

For Part Numbers: 601-673,
601-677, 601-675, 602-677 and
601-679

Component Details

Item No.	Part Number	Description	QTY
1	*Style Index	Bench Plank	2
2	*Frame Index	Bench Leg	2
3	126-704	3/8 x 3 1/2" Button Head Bolt	8
4	316-601	3/8 Washer	8
5	416-505	7/32 Allen	1
6	516-400	LocTite	1

Additional Components for Portable Frame

7*	613-614	Portable Brace*	2
8*	126-701	3/8 x 1 1/4" Button Head Bolt	1
9*	316-601	3/8" Washer	6
10*	126-602	3/8" Nylon Lock Nut	3
12*	126-710	3/8 x 3 1/2" Button head bolt	2

Additional Components for Surface Mount

11**	531-062	3/8 Concrete Anchor	8
------	---------	---------------------	---

*Only required on units that have a portable frame.

**Only Required on Surface on units that have a surface mount frame

Note: Refer to the frame index and style index for part identification and component specific instructions.

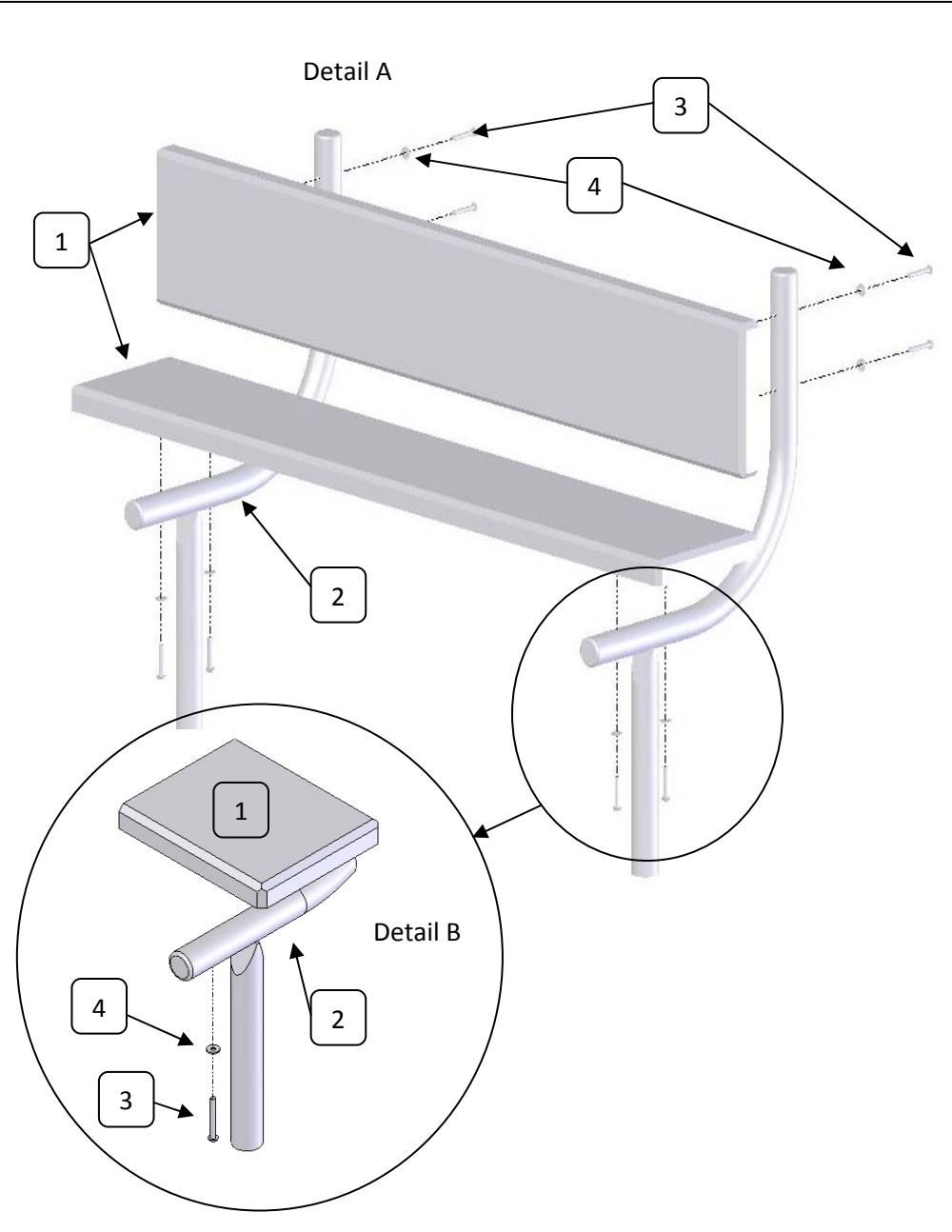



6' Standard Bench with Back

For Part Numbers: 601-673,
601-677, 601-675, 602-677 and
601-679

Important

- Please keep a copy of these instructions in your files. There is important replacement part information in them that will assist you in the event a part is ever needed.

Assembly Information

- Read all assembly instruction before starting assembly.
- Verify that all parts were received by comparing the parts received to the component list on page one.
- If your product mounts to something (surface mount, in ground or wall mount) you will assemble the entire product before drilling holes or mounting frame in order to ensure proper layout.
- CONTACT YOUR DISTRIBUTOR ABOUT ANY PARTS YOU ARE MISSING. You must report missing parts within 10 days of delivery.
- Hand-tighten all bolts during the initial assembly (unless specifically told to tighten completely in the instructions). Once the unit is fully assembled and square you should completely tighten them.
- Other than when a specific step in the assembly instructions specifies "to not apply Loctite, we recommend applying a small amount to all assembly bolts.

General Maintenance

- It is recommended that you inspect the product monthly for loose bolts and broken parts. If replacement parts are needed please refer to these instructions for part numbers and descriptions then call your distributor to order replacements.

Assembly Instructions

NOTE: Only assembly your bench at this time. After it is assembled you may refer to the frame index so you can identify your frame type and then locate the specific mounting instructions for that frame.

1. Attach one of the Bench Planks (1) to one of the Bench Legs (2) by inserting two 3/8" x 3 1/2" Button Head Bolts (3) and 3/8" Washers (4) through the bottom of the leg and into the factory installed nuts on the mounting plate attached to the bottom of the bench plank (Detail B)
2. Following the same procedure established in step 1, attach the same Bench Plank (1) to the second Bench Leg (2) using two 3/8" x 3 1/2" Button Head Bolts (3) and 3/8" Washers (4).
3. Attach the second Bench Plank (1) to the Bench Legs (2) following the procedures outlined in steps 1 and 2. Use detail A from the first page as a reference.
4. Now identify your frame type from and follow the specific instructions for your frame. Again, use the frame index page to complete this step.



6' Bench Style Options

Style Identification

In the event a replacement part is needed, it is important that you are able to identify not only the product but the style of product you ordered. The images to the right represent all the style options that are available for the product you purchased. Please identify your style and it's corresponding part number before you contact your distributor or the manufacturer for replacement parts.

Currently, SportsPlay Equipment offers four style options. Rolled edge with perforated steel, beveled edge with perforated steel, rolled edge with expanded steel and beveled edge with expanded steel.

To identify your product style you must first define the edge. If it has a radius it is a rolled edge and if it has a 45 degree angle it is the beveled edge. Expanded steel is easily identified by its distinct weave pattern. The perforated steel option is simply sheet metal that has been punched with a pattern of holes.

Rolled/Perforated

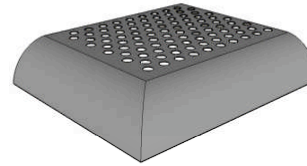

613-501PR

Beveled/Perforated

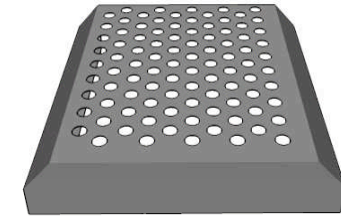

613-501PB

Rolled/Expanded

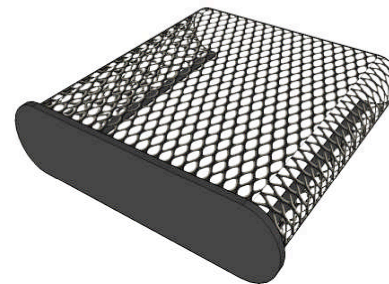

613-501ER

Beveled/Expanded

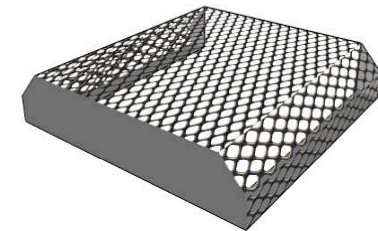

613-501EB



Standard Park Bench Frame Style Index and Install

In Ground Mount Instructions:

1) **IN GROUND MOUNT** (*Refer to the Footing Diagram below*) – Dig two holes 12" in diameter, 20" deep and span 76" from center to center.

2) Place the bench into the holes and level (also make sure bench is still square). Completely fill the holes with concrete. After you add the concrete, make sure that it didn't cause the bench to shift out of level.

3) We recommend that the top of the concrete slope down and away from the Bench leg to help with water runoff.



613-502I
In ground
With Back

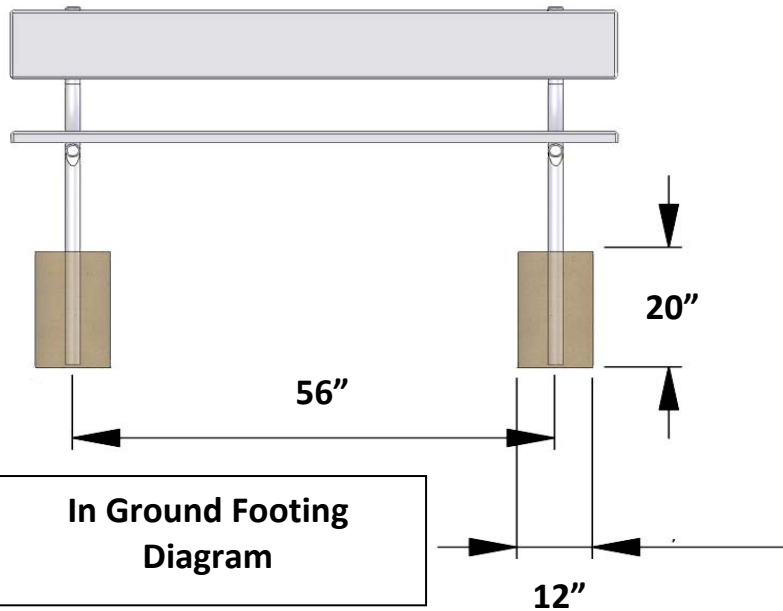

613-502 Portable With Back



Portable Frame Instructions:

1) After assembling the unit attach both of the cross braces (7) to the holes located on the bottom side of the bench in the center of the long support brace, with one 3/8 x 1 1/4" button head bolt (8), two 3/8" washers (9) and one 3/8" lock nut (10).

2) Attach the other end of the braces to each leg using one 3/8 x 3 1/2" button head bolt (3), two 3/8" washers (9) and one 3/8" lock nut (10) for each leg. Completely tighten these bolts.

3) Finally, tighten all remaining bolts.

Surface Mount Instructions:

1) After bolts have been tightened, place the bench in the desired permanent location and mark the holes from the mounting plate onto the mounting surface. Move the bench and drill the marked holes 3.75" deep with a 3/8" bit.

2) Remove the nuts and washers from the anchor bolts (11) and place the anchor bolt into the drilled holes. Back the bolt in the anchor out far enough so there are sufficient threads exposed for the nut after the bolt goes through the mounting plate and washer.

3) Put the bench back in place. Put the put a washer and hand tightened nut on each anchor, do not completely tighten until all nuts are hand tight. Square and level the bench and then tighten all other bolts.



613-502S
Surface
With Back

6' Bench with Back

FOR PART NUMBERS: 602-602, 602-605, 602-615, 602-619, 602-608, 602-611, 602-613, 602-617

Front View

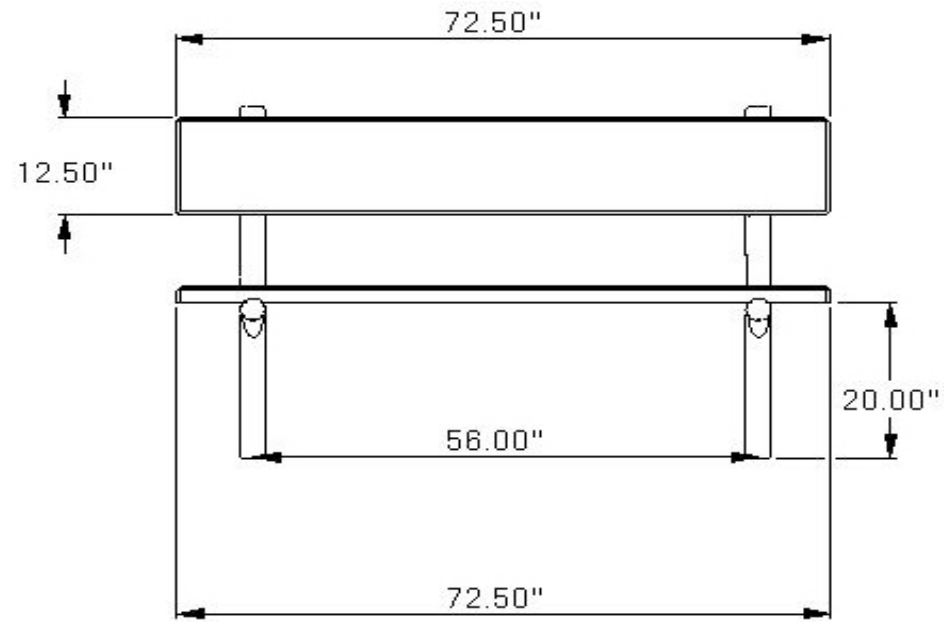

Top View

