



911-132 Model Alicia



800-727-8180

www.sportsplayinc.com

INDEX

INDEX	2
Tool and Material Checklist.....	3
Introduction.....	4
Quick Guide	5
Safety Surfacing/Fall Heights.....	7
Punch List	9
Top Down View Scale	11
Footing Diagram	12
Post Installation.....	13
Deck and Pipe Clamp Installation.....	15
Deck Clamp 903-002	15
Pipe Clamp 903-001	15
Deck Clamp Plan:	16
Pipe Clamp Plan:.....	17
Deck Installation	19
Square Deck	19
Triangle Deck.....	19
Deck Plan:	20
Transfer Station 902-258	21
Transfer Station Plan:	23
Kickplate	25
Kick Plate Plan:.....	26
Triple Rail Slide 902-203,4	27
Triple Rail Slide Plan:.....	28
Rock Wall 3', 4', & 5' 902-273-3,-4,-5.....	29
Rock Wall Plan:	30
Panel Climber 902-267-3, 4', 5'	31
Panel Climber Plan:	32
Zig Zag Loop Climber 902-112.....	33
Zig Zag Loop Climber Plan:	34
Chain Net Climber 902-408, -09, -10	35
Chain Net Climber Plan:.....	36
Guard Wall 902-135-W	37
Guard Wall Plan:.....	38
Steering Wheel 902-114	39
Steering Wheel Plan:.....	40
Tic Tac Toe Panel 902-121.....	41
Tic Tac Toe Panel Plan:	42
Bump Wave Slide 902-284, 5, 6.....	43
Bump Wave Slide Plan:	44
Corkscrew Climber 902-133-3, -4, -5.....	45
Corkscrew Climber Plan:	46
Bubble Panel 902-117	47
Bubble Panel Plan:	48
5' Sectional Slide 902-216.....	49
5' Sectional Slide Plan:.....	51
Periodically check hardware	51
Label Installation	52
Top of Surfacing Label	52
Warning Label	52
Manufacturer Label.....	52
Trouble Shooting	53
Safety Checklist	54
Photo Appendix	55

Tool and Material Checklist

- To dig holes, the best method is a tractor with an auger. Use a 12" auger bit. No matter what you use, there will be a considerable amount of hand digging as well
- Shovels, long handled spades
- Post hole diggers
- Wheelbarrows
- Large construction bar (generally 5' long).
- Spray paint, to mark ground holes
- Pry bar
- Claw hammers
- Large dead-blow rubber hammers
- Small (3lb) Sledgehammer, to use in blocking the posts
- 7/32", 3/6", 1/8" Allen wrenches: These are very important. Several different types are helpful (socket style, small "L" arm, wrench styles etc.)
- Vise grips, large, regular and needle-nose
- 3/4" and 1/2" and 9/16" sockets, both 1/2" and 3/8" drives
- 6' and 8' stepladders, strong ones
- Extension cords (also duplexes to run more than one cord)
- 1/2" drill and 3/8" drill
- 1/2" and 1/2" drill bits and 1/2" spade bits
- Levels: magnetic torpedo, 4' long etc. (as many as possible)
- Shims and blocks from scrap lumber and a saw to cut sizes on site
- Small, skinny, flat shims are helpful in raising posts etc. 2" by 4" and 2" by 6" and Plywood are also helpful
- Pencils and markers
- String line
- Bar clamp 4'
- Sometimes bracing material is helpful (2" x 4" x 6' studs with sturdy lag bolt/nut combinations)
- Files, sandpaper, wood scraps
- Stones
- Cement
- Surfacing
- One brick per post

Introduction

BEFORE STARTING INSTALLATION OF YOUR PLAYGROUND, PLEASE READ INSTRUCTIONS THOROUGHLY.

SITE REQUIREMENTS:

The Playground system is designed to suit a level site. Should there be any falls or slopes on the site; care should be taken to accommodate the entry and exit points and to maintain the correct height. There should not be more than 3” of drop in grade per every 10’.

The site must be inspected for adverse conditions: All sites must be checked for existing utilities such as electricity, gas, water or any other underground hazards. 1-800-DIG-RITE is the number to call to have the services located.

1. Roots, rocks, or other natural obstacles that may pose as a trip hazard.
2. Poor drainage areas.
3. Broken glass or foreign objects around building site.

MAINTENANCE:

As an owner, it is most important that you are aware of your responsibility to insure safe use of your new equipment. It is necessary to install equipment correctly according to the installation instructions provided and inspect the equipment at regular intervals. During inspection, if any part is found damaged or excessively worn, equipment should immediately

be put out of service while the part is replaced. Lack of maintenance will result in premature wear, reduced life expectancy, and possible failure that might result in injury.

All SportsPlay Equipment play events have been engineered to meet all applicable safety guidelines, but if installed improperly, these problems may occur:

- Entrapment gaps (between 3 1/2” and 9” }
- String Entanglements
- Protrusions

Make sure that any bolt end that protrudes more than 2 threads past the face of the nut is trimmed and deburred smoothly. Always double-check your work.

Installation must adhere to the manufacturers assembly manual and all other applicable safety guidelines.

PLAY AREA:

The area immediately above and around the play structure must be free of any obstructions such as:

- Trees
- Other Play Equipment
- Buildings
- Overhead Power lines

Make sure the play area has all the required safety surfacing and the minimum fall zones as required by the safety guidelines. These guidelines can be found at www.cpsc.gov.

**CHILDREN MUST BE SUPERVISED AT ALL TIMES.
No playground is safe without adult supervision!**

Quick Guide

SITE – Make sure the area of installation is relatively level, free of obstacles and underground utilities. If a slope exists, care must be taken to accommodate entry and exit areas to insure they maintain the correct heights. Call 1-800-DIG-RITE to have a technician check the area for underground utilities. This service is free.

MATERIAL INVENTORY – Locate your Component Checklist and the 2d top down drawing included in the instructions. Use both to identify, inventory and best position the parts around the perimeter of the area. If you find damaged or parts missing, contact your SportsPlay Distributor immediately.

INSTRUCTIONS – Thoroughly read the instruction booklet BEFORE beginning the installation. Pay special attention to the pages describing post and deck installation. These are the ‘bones’ of your playground. If they are not properly installed, the remaining events will not install correctly. **KEEP THESE INSTRUCTIONS ON FILE.**

TOOLS – Locate the Tools Checklist in the instructions. Make sure all necessary tools are available at installation time. If you are using volunteers, send a note to them that includes the tool list. You may be able to borrow most items instead of renting.

SUPPLIES – Set your installation date and order supplies from your local building center. You will need some flat

concrete stones for blocking holes, some scrap lumber for bracing and cement. You can figure about 2 80# concrete bags per hole.

DECK LAYOUT – Find the grid drawing in the instruction booklet. Decide which way to orient the structure. ALL fall zone measurements MUST be accommodated. Locate the lowest deck on the drawing. You can start laying out the structure by placing the lowest deck on the ground and then double check your measurements. Measure twice, install once! Consult the instruction booklet for post and deck installation instructions.

BRACING – As the decks and kick plates are installed, be sure to level the posts and place braces in the holes to keep them from shifting. Periodically, plumb and level all posts as you work your way around the playground.

COMPONENT INSTALLATION – Consult the instruction booklet for separate installation instructions for each component on your playground. Begin installing from the lowest deck in a clockwise rotation around the structure back around to the starting deck. Tighten panels as you go, making sure to plumb and level posts.

VISUAL INSPECTION – After all components are installed and tight, do a visual inspection to ensure the panels and posts are level, in the proper place, and look good with respect to one another. Once satisfied, you are ready for concrete.

CONCRETE – Mix the concrete according to the directions. DO NOT mix directly in the hole. Fill each hole to within 2 inches of the original surface. Crown for drainage, and cure 48 hours.

SECURE AREA – Fence off or lock area to insure that NO ONE can play on the playground until it is completely finished. You may consider contacting local law enforcement to inform them of the new installation and ask them to check the area frequently during the night.

BACKFILL AND CLEANUP – 48 hours after pouring cement, backfill all of the holes with dirt to the original ground level and make sure the area is free of any tools, hardware, or sharp objects.

SURFACING – Use the chart on page 8 to decide how much safety surfacing is required. Before spreading loose fill surfacing, be sure to install a weed barrier outside the fall zone dimension, then spread the safety surfacing.

LAST THING – Make one more tour around the playground and physically make sure all hardware is tight.

OPEN FOR PLAY – After the safety surfacing is installed and the hardware has been checked for tightness, your playground is ready for play.

MAINTENANCE - Consult your instruction booklet for the maintenance checklist. Schedule and complete periodic maintenance checks of the entire playground. If any hardware is worn, or any item missing or broken, close the playground and contact your SportsPlay distributor for replacement parts.

Check resilient surfacing depths, move or add additional surfacing if necessary. Make sure the playground area remains free of obstacles, broken glass or other sharp objects.

Safety Surfacing/Fall Heights

You must consider the type of safety surfacing you will use before beginning the installation process. There are two general types, organic/loose fill or synthetic unitary. Both materials have advantages and disadvantages and it is likely that your client's budget will dictate the material of choice. Always have all options available as product quality and long-term performance may cause your client to reevaluate their original budget.

When installing a unitary safety surfacing material such as rubber mats or poured-in-place, you will need to pour a concrete slab so that the rubber material can be secured. This type of product cannot be placed on dirt.

If a loose fill surface such as wood chips is selected, you will need to consider containment borders. There are many products to choose from including hard plastic and natural products such as wood. Creosoted railroad ties are NOT recommended. Loose fill materials like wood chips are easily displaced, so 12" deep is generally satisfactory. Also remember that loose fill will compress with repeated use.

Weed mat: Some use a landscaping fabric material that allows drainage but prevents weed growth. Weed mats are installed after the structure is installed but before the resilient surfacing is installed.

Borders: Building borders above ground, below grade, or on grade depends upon the area in which you live. Assuming you must use 12" of resilient surfacing, there are three basic types of installation:

1. 12" below existing grade
2. 6" below and 6" above existing grade
3. 12" above existing grade

The tallest deck on the unit generally defines the maximum fall height of a structure. If upper body equipment (horizontal ladder) is attached, the fall height is then the distance from the highest part of the equipment to the protective surfacing. Refer to the Top Down View to determine the maximum fall height.

Since the structure will be installed at dirt grade, the height of the resilient surfacing must be determined and factored into the height of installation of decks. For example, if the resilient surfacing will be 12" deep, a 3' deck height will actually install at 4'. When the structure is completed and the surfacing is installed, the deck then will be 3' above the level of the resilient surfacing.

Safety Surfacing Chart

Chart taken from The Handbook for Public Playground Safety written by the U.S. Consumer Product Safety Commission (CPSC) page 5 (www.cpsc.gov).

Table – Critical heights (in feet) of Tested Materials

Material		Uncompressed Depths		Compressed Depths
	6”	9”	12”	9 “
Wood Chips	4	10	11	10
Double Shredded Bark Mulch	6	10	11	7
Engineered Wood Fibers	6	7	>12	6
Fine Sand	5	5	9	5
Course Sand	5	5	6	4
Fine Gravel	6	7	10	6
Medium Gravel	5	5	6	5
Shredded Tires	10-12	N/A	N/A	N/A

These directions are written based upon a depth of 12” of resilient surfacing.

Do not forget to calculate the compressed resilient surfacing depth needed and adjust your “dirt grade height” accordingly.

Punch List

Step 1: Layout

1. Lay square deck on ground in the desired location and measure from all corners to insure there is adequate room. (Refer to Grid Drawing pg. 11)
2. Most installers usually like to orientate the playground so that the entry point of the playground is facing either the sidewalk or the direction from which the children are coming.

Step 2: Holes

1. Mark the locations of all post holes by laying out all the decks in the correct orientation. Make sure all the decks are touching each other and flush on the edges. Then use the center point of each deck corner and marking them with paint or a wooden stake.
2. After the holes are marked, move the decks out of the digging area and dig the first four holes per the footing drawing on page 12.
3. Fill or dig the depth of 1 main hole to what is required; this hole will be used to get the other three holes the same depth in reference to each other. Make sure the hole is flat and tamped solid, then place a small piece of plywood or brick in the bottom. You must take this in account when determining the hole depth.
4. Now, if possible, use a transit to maintain the same hole depth on the remaining three holes, if you don't have access to a transit, then park a line on the first post about two inches above the dirt level. Then measure up from the bottom of the post to this mark and mark a line

on the other three posts at the same distance. Now use a four-foot level across to each line, raising or lowering as necessary to make the lines level. Repeat this for the remaining two posts.

Step 3: Deck and Post Installation

1. Measure 36" plus the amount of safety surfacing you are planning on using (example: $36" + 12" = 48"$ from the existing ground level). Make a mark on the first post at this measurement and then measure from the bottom of post to this mark and make a mark on the remaining three posts at the same measurement.
2. Install a deck clamp per instruction page 15. Tighten all hardware.
3. Now make sure that you have two other helpers and the required deck clamp hardware.
4. Place four posts into the holes and let them rest on the hole edges. Now install the deck on two of the deck clamps and install hardware down through the deck and clamp and install the locknut on the bottom. Do not tighten at this point.
5. Next place the other two posts on the deck and install the hardware.
6. Continue building the main structure by adding the overhead climber, kickplates and other decks and posts per the illustration until all the decks, kickplates, and posts are installed. Make sure the posts are level as you tighten the hardware, this will make the component installation much easier.
7. It may be necessary to brace the deck and posts with lumber to make sure they stay in place and level. Also make sure the deck was installed level.

Step 4 – Component Installation

1. Begin by installing Panel Climber per instructions on page 31.
2. Now install the triple rail slide per instructions on page 27.
3. Install the Rock Wall per instructions on page 29.
4. Now install the Zig Zag Loop Climber per instructions on page 33.
5. Install the Transfer Station per instructions on page 21.
6. Next install the Chain Net Climber per instructions page 35.
7. Now install the Tic Tac Toe Climber per instructions page 41.
8. Install the Guard Wall w/Steering Wheel per instructions on page 37.
9. Next install the Bump Wave Slide per instructions on page 43.
10. Install the Guard Wall per instructions on page 37.
11. Now install the Corkscrew Climber per instructions on page 45.
12. Next install the Bubble Window panel per instructions on page 47.
13. Finally install the 5' Sectional Slide per instructions on page 49. Level and Tighten.

Step 5: Concrete

1. Once all components and posts are tight and level, you may concrete. A good rule of thumb is two 80 lb. bags of concrete per hole. Do not “dry bag” the concrete, always mix per instructions on concrete bag. Be sure to leave concrete about 2” from the top of the ground to allow backfill.
2. Be sure that all splattered concrete is washed off of the posts and components while it is still wet.
3. Block off installation area for at least 48 hours.

Step 6: Final after 48 hours

1. Return in 2 days to backfill concrete, drill and install drive (roll) pins per instructions, and install safety surfacing.
2. Inspect all components to insure the hardware is tight and all panels are level.
3. Make sure all tools and dropped hardware are removed from play area.
4. Open the playground.

Top Down View Scale

Accurate scale drawings have been included at the end of these instructions for your convenience.

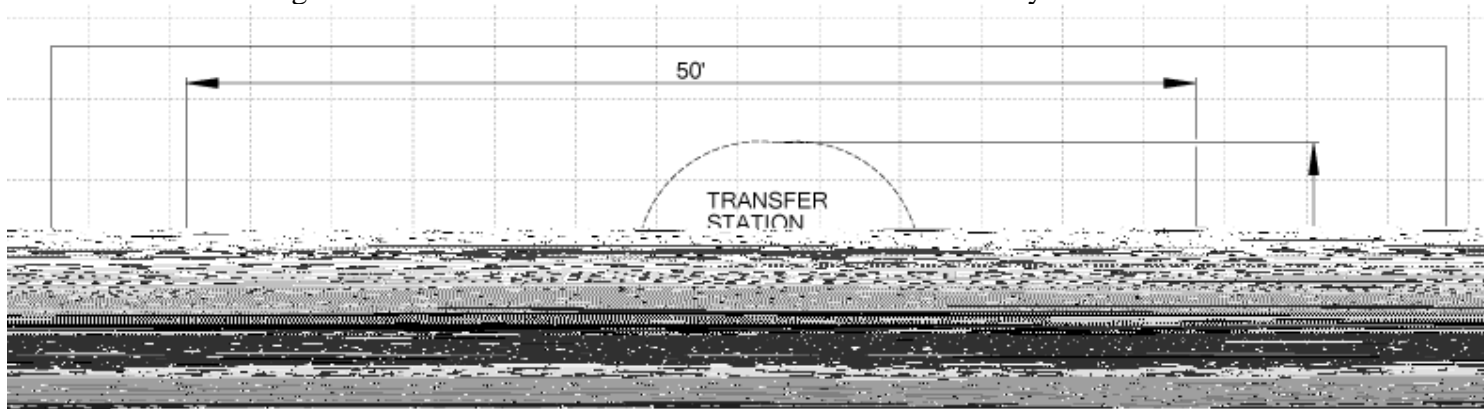

Footing Diagram

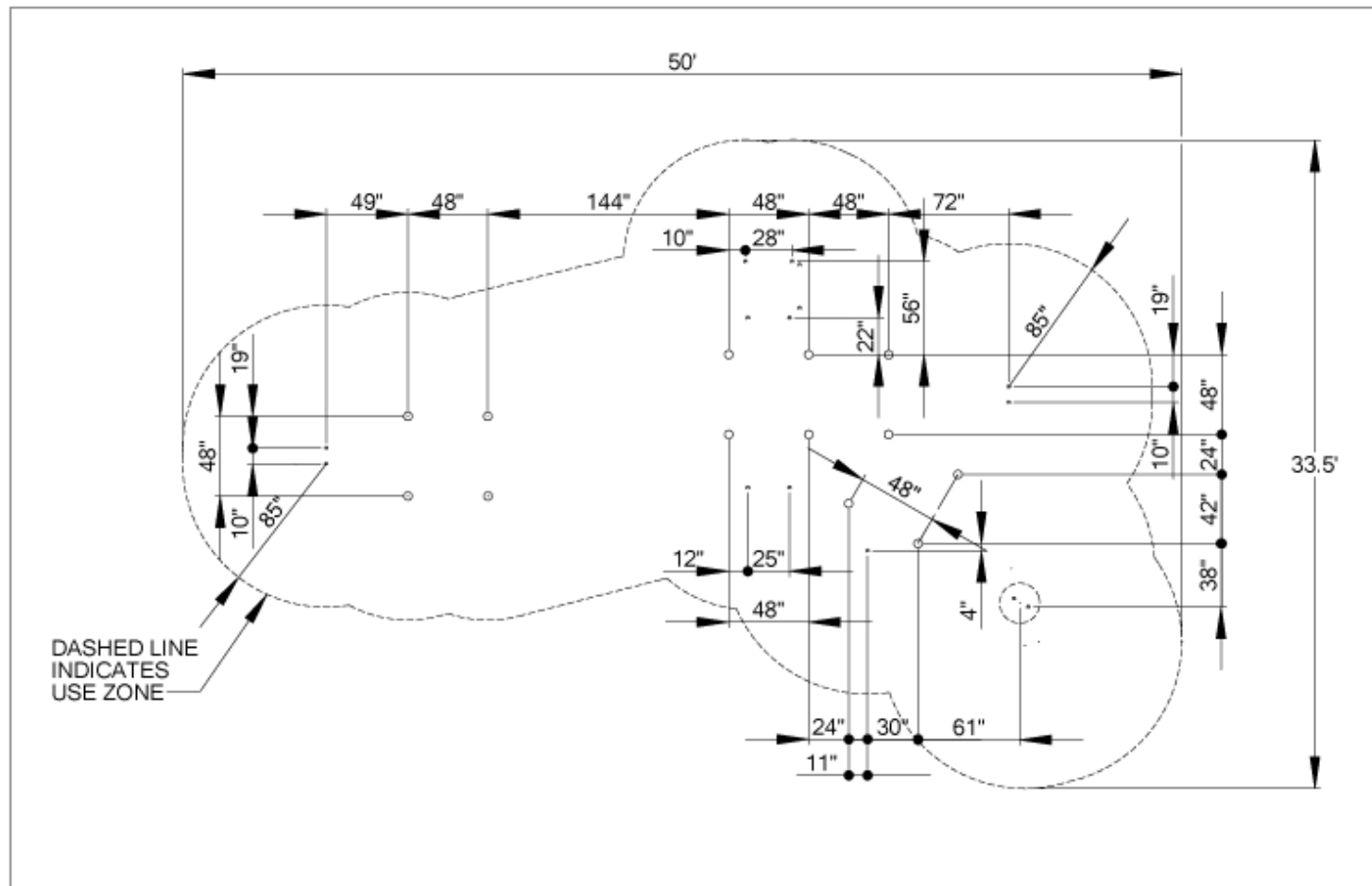

 <p>SportsPlay 5642 Natural Bridge 800-727-6180 Fax: 314-389-9034 www.sportsplayinc.com</p>	<p>Age Appropriateness: 5-12 Yrs Size: 36" X 23" X 3" Use Zone: 50' x 33.5' Critical Fall Height: 60"</p>	<p>Drawn By: Candy</p>	<p>Date: 06-29-05</p>	<p>Alicia 911-132 SportsPlay</p>
		<p>CFSE: Compliant ASTM: Compliant</p>		

Post Installation

Footing size may vary due to local soil and weather conditions. Base of footing **MUST** be below the frost line.

- Dig holes straight down, with a flat bottom and 12” wide making sure to dig holes wide and not cone shaped.
 - Hole depths are 22” deep (this depth changes slightly with grade).
 - Place a brick in the bottom of the hole.
 - Post is placed on top of the brick.
 - If the bottom is not flat and roomy, there will be no room to adjust. It is much easier to have too much room rather than not enough.
 - You can dig by hand using a posthole digger, but a tractor with a 12” auger will make the task much easier.
 - Post tops should be level with one another.
 - **USE A LONG, HEAVY CONSTRUCTION BAR** to adjust levels of posts, legs, etc. **DO NOT** try to level by pushing posts at shoulder or waist length. Carefully bump the posts at the bottom **IN THE DIRECTION YOU WANT THE POST TO GO**.
 - Mark holes and dig by laying the deck on ground and using it as “jig”. Place (4) deck clamps, one per corner, spray paint through middle of clamp onto ground. This marks where the centers of the postholes should be.
 - Remove the deck and clamps from the area.
 - Dig the (4) holes 22” deep and 12” wide. Holes are straight down and flat-bottomed. Install 10” diameter plywood in hole bottoms and place a brick in the bottom of the hole.
- Use a marker to mark 22” from bottom of posts. Use these marks so you can run a 4’ level across marks to make sure the tops of the posts are equal to each other. If line marks are on bubble, then post tops should be on bubble to each other.
 - Install the red plastic end caps on post bottoms.
 - Since your holes are 12” diameter and posts are centered in holes you have approx. 3 1/2” all around the post.
 - Block the posts into center of holes when posts are on bubble. Use scrap lumber and wedges to solidify the posts in their holes as you level the posts. Re-blocking may be necessary at times in order to achieve level. You may also have to widen your holes if they are not dug on center.

Top down view of post set into hole:

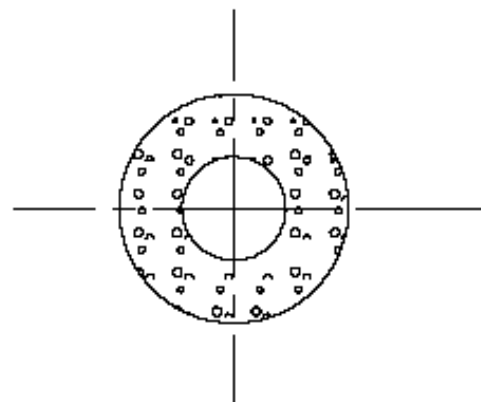

Side view of installed post

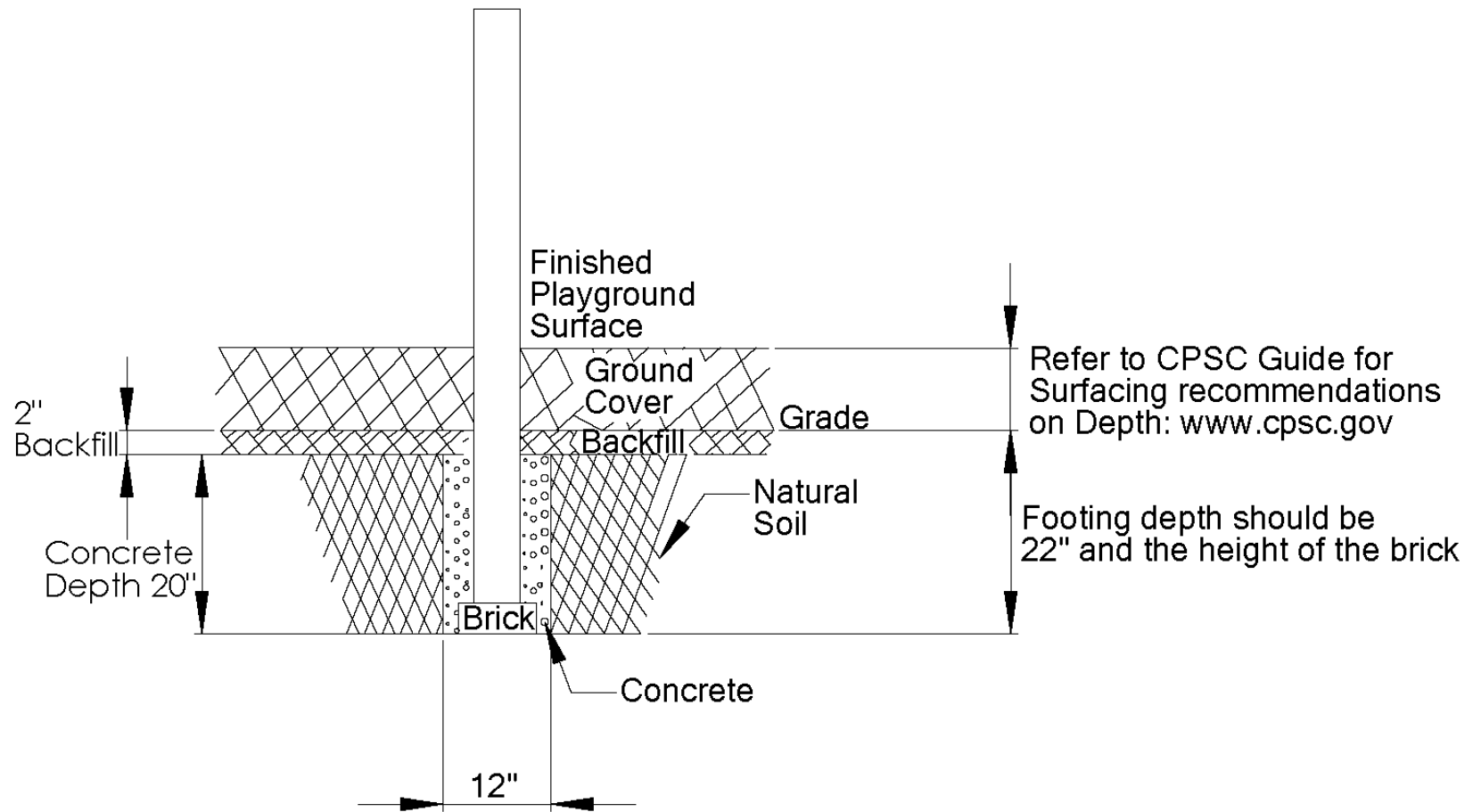

Deck and Pipe Clamp Installation

Deck Clamp 903-002

Item #	Part #	Part Description	Quantity
1	105-025	Clamp half FRONT	1
2	105-026	Clamp half BACK	1
3	116-600	1/2" x 2 1/2" Button Head Bolt	1
4	196-550	Roll Pin 1/4" x 1 3/4"	1
5	236-601	3/8" T-Nut	1
6	196-555	Roll Pin 1/4" x 3/4"	1
7	126-703	3/8" x 1" Button Head Bolt	1
8	226-801	1/2" Lock Nut	1
9	316-801	1/2" Washer	2

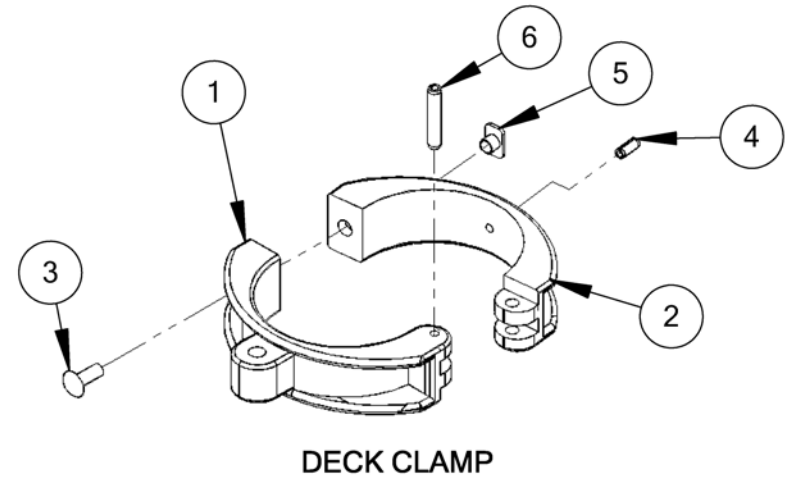

Pipe Clamp 903-001

Item #	Part #	Part Description	Quantity
1	904-002	Clamp half – BACK	1
2	904-001	Clamp half – FRONT	1
3	126-706	3/8" x 1 3/4" Button Head Bolt	2
4	196-807	Socket Set Screw 3/8" x 3/8"	1
5	236-601	T-Nut 3/8"	2
6	196-555	Roll Pin 1/4" x 3/4"	1

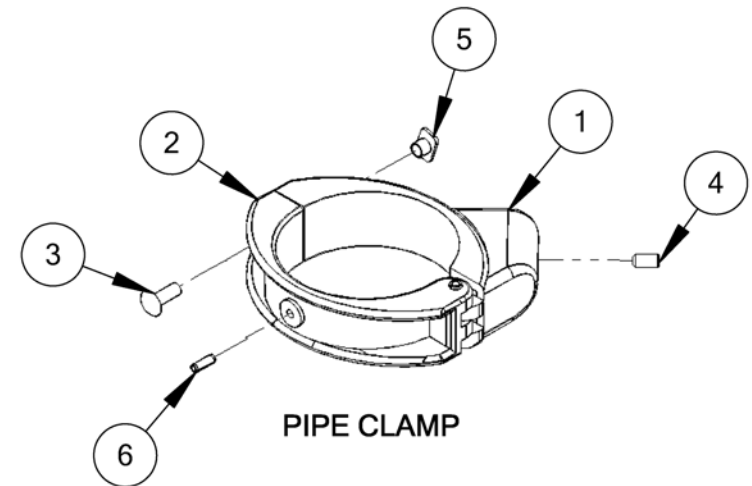

Deck Clamp Plan:

The deck clamps connect to the main upright posts according to the deck height(s) located on the Top Down View.

INSTRUCTIONS:

1. Install the deck clamps to the center of the deck corners. If clamps are off center, then the line of posts will not be straight and the components will not connect properly.
2. Raise the deck to the proper level according to the deck height found on the Top Down View.
3. Hand tighten the button head bolt. Do not over tighten because the post may 'swing'.
4. Decks attach to the clamps using 1/2" x 2 1/4" Button head bolts, washer on top and bottom with 1/2" lock nuts. Connect the deck bolt firmly.
5. Check the deck and all four posts to insure they are level and the deck is at the proper height.
6. Once the deck and all four posts are level and the deck is at the proper height, tighten the clamp onto the post.
7. Install Roll Pins

When the playground has been built and there are no more adjustments, drill through all of the clamps (through pre-drilled 1/4" drill holes in clamps) and the 5" O.D. posts. Use a sharp 1/4" metal drill bit to drill a straight hole. Do not egg out the holes. Then tap a 3/4" roll pin through clamp into post so that the pin is flush with the clamp. Do not allow pins to protrude. If a pin has been installed but a clamp or component has to be moved, the pin can be knocked through into post.

IMPORTANT: Extra roll pins can be installed through certain high traffic clamp applications such as firepoles, roof clamps, handholds, etc. Finally smooth down any drill holes etc., with steel wool or a file.

SPECIFICATIONS:

Event: Clamps shall be 6061T5 aluminum fastener for 5" OD posts weighing 2.21 lbs.

Paint shall be electrostatically applied oven cured powdercoat.

Hardware: Stainless Steel tamper resistant

MAINTENANCE:

Touch up any marred paint surfaces.

Periodically check hardware for integrity and tightness.

Pipe Clamp Plan:

The pipe clamps connect to the main upright posts according to the height of the events found on the Top Down View.

INSTRUCTIONS:

There are two ways to install the clamps:

1. Pre-install the clamp to the post first, then slide the 1 3/8" O.D. pipe into the clamp.
2. Install the clamp over the 1 3/8" pipe first, and then install the clamp to the post.

You will do both of these applications, depending on the circumstances.

1. Clamp is installed to post first, then 1 3/8" O.D. pipe moves into clamp.
2. Install clamp to pipe first, then to post. Fit clamp onto the pipe, and install the clamp "sideways" over the post. You may have to assert some pressure. **MAKE SURE PIPES ARE ALL THE WAY INTO CLAMPS BEFORE INSTALLING ONTO POSTS.** (2 1/4" end of pipe goes inside clamp) Use rubber hammer for clamps.

You can use a marker to mark the location of clamps when pre-installing posts. If a pipe clamp is close to another clamp or a deck etc. it may be necessary to pre-tighten the set screw to clamp, then move clamp into position. For convenience of installing button head bolts, it is necessary that the bolt heads face outward.

If the clamp is crooked to the pipe, and the pipe WILL NOT be able to enter the clamp. Sometimes, you can coax the clamp onto the pipe with a rubber hammer. If that will not work, take clamp off and install it "sideways", placing it on the pipe first and then onto the post. Pipes enter into clamps 2 1/4" deep. Components like walls, vertical climbers, ladder ends, etc. are all 48" long, and the pipe ends have to go straight into the clamps or the connection will not work. If you force a clamp it can break!

All of our components such as walls, climbers, horizontal ladders, arch walls etc. are 48" wide, and clamp to the middle of the posts. That means that these components are centered onto the posts at 48" on center.

There is up to 4" of extra room in the pipe clamp cavities, 2" to the left and 2" to the right. This means that it is possible to be either too far left or right of center. Keep in mind that all **COMPONENTS HAVE TO BE CENTERED**, that the left and right are inserted equally into clamps!

When the playground has been built and there are no more adjustments, drill through all of the clamps (through pre-drilled 1/4" drill holes in clamps) and the 5" O.D. posts. Use a sharp 1/4" metal drill bit to drill a straight hole. Do not egg out the holes. Then tap a 3/4" roll pin through clamp into post so that the pin is flush with the clamp. Do not allow pins to protrude. If a pin has been installed but a clamp or component has to be moved, the pin can be knocked through into post.

Extra roll pins can be installed through certain high traffic clamp applications such as firepoles, roof clamps, handholds,

etc. Finally smooth down any drill holes etc., with steel wool or a file.

SPECIFICATIONS:

Event: Clamps shall be 6061TS aluminum fastener for 5" OD posts weighing 2.21 lbs.

Paint shall be electrostatically applied oven cured powdercoat.

Hardware: Stainless Steel tamper resistant

MAINTENANCE:

Touch up any marred paint surfaces.

Periodically check hardware for integrity and tightness.

Deck Installation

Square Deck

Item #	Part #	Part Description	Quantity
1	905-705	Square Deck	1
2	903-002	Deck Clamp Assembly	4
4	316-801	1/2" Washer	8
5	226-801	1/2" Lock Nut	4
6	126-703	3/8" x 1" Button Head Bolt	4

Triangle Deck

Item #	Part #	Part Description	Quantity
2	903-002	Deck Clamp Assembly	3
3	905-710	Triangle Deck	1
4	316-801	1/2" Washer	6
5	226-801	1/2" Lock Nut	3
6	126-703	3/8" x 1" Button Head Bolt	3

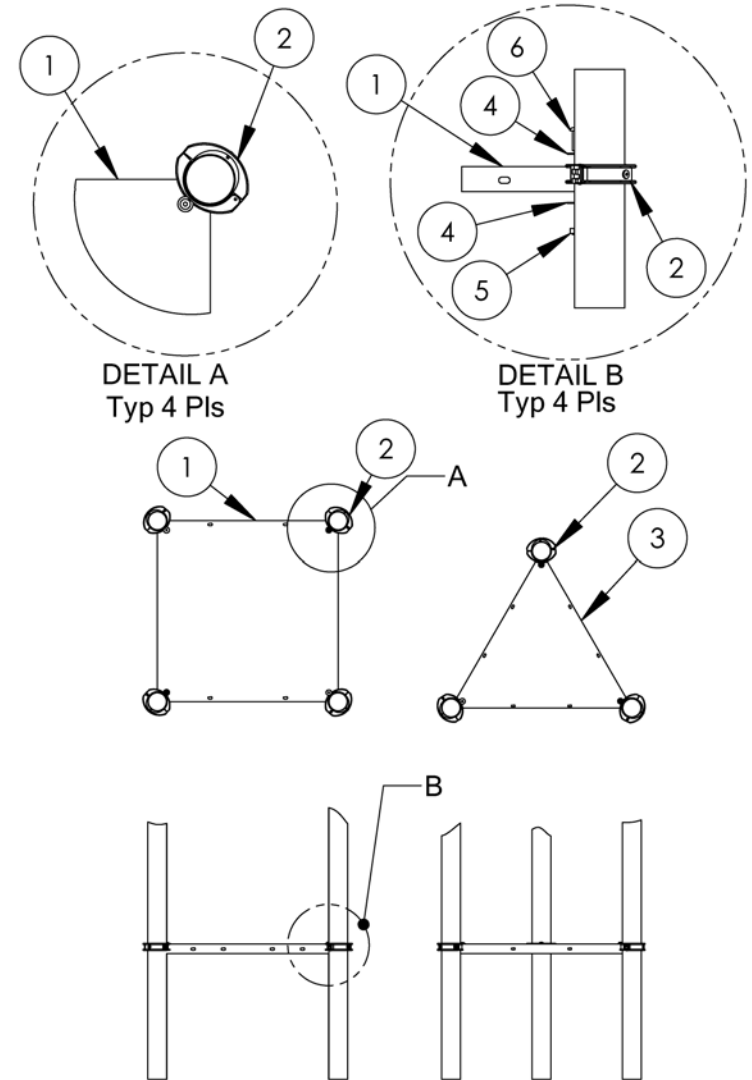

Deck Plan:

The deck(s) connect to the main upright posts according to the specifications found on the Top Down View.

INSTRUCTIONS:

There are two methods:

The BEST method is to make a table or stand to place your deck on at the required deck height. The table will stabilize the deck so you can level it.

You can make a table from sawhorses.

Deck stand or table holds deck while you build around it.

Blocks stabilize the posts while table stabilizes the deck.

The second method is to pre-install the (4) deck clamps so that there is 42 1/4" between the holes in the deck clamps.

Use a level and a marker to make sure the clamps are level to each other.

Place deck onto clamps and bolt.

This method works but is less stable than the first method. The deck and posts will stabilize more as you add components

Pre-install deck clamps and level.

SPECIFICATIONS:

Event: Steel Deck shall be constructed of #12 gage perforated steel, welded to 2 1/2" x 2" by 18" angle frame, 1/4" endplates, center-bracing, plastisol coated and oven cured.

, welded to 2 1/2" x 2" by 18" angle frame, 1/4" endplates, center-bracing, plastisol coated and oven cured. Square Deck is 48" x 48" (2304 square inches), Hex Deck is 7 1/2" by 8' (8640 square inches); Triangle is 48" square 16 gage.

Paint: Oven cured plastisol

Hardware: Stainless Steel tamper resistant

MAINTENANCE:

Touch up any marred paint surfaces.

Periodically check hardware for integrity and tightness.

Transfer Station 902-258

Item #	Part #	Part Description	Quantity
1	905-704	Transfer stairs	1
2	905-715	Transfer deck	1
3	905-716	Transfer step	1
4	913-224	Plank leg	2
5	913-225	Pipe w/ hand holds	1
6	913-226	Support pipe	1
7	903-001	Pipe clamp	2
8	913-227	Hand rail left	1
9	913-228	Hand rail right	1
10	913-230	Inside leg	2
11	105-016	1 7/8" aluminum pipe plug	2
12	126-701	3/8" x 1 1/4" button head bolt	14
13	126-704	3/8" x 3" button head bolt	2
14	126-707	3/8" x 1 1/2" button head bolt	4
15	126-708	3/8" x 2 1/4" button head bolt	4
16	217-104	3/8 rebar	4
17	226-602	3/8" Nylon lock nut	24
18	316-601	3/8" Flat washer	44
19	385-901	1 3/8" black plug flat	2

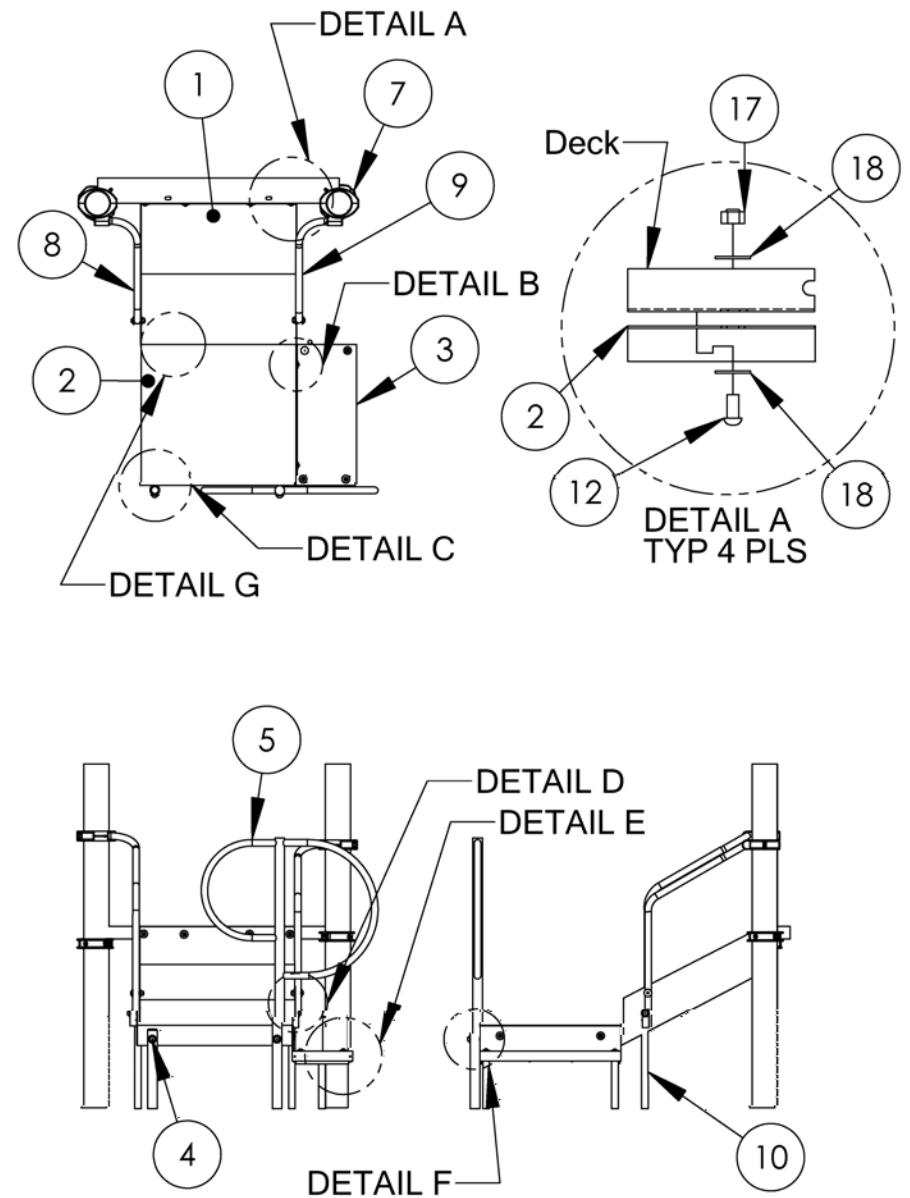



3' TRANSFER STATION

902-258

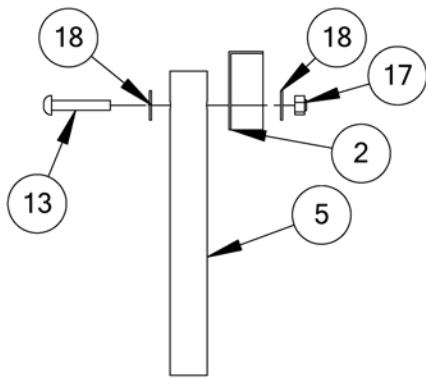

DETAIL F

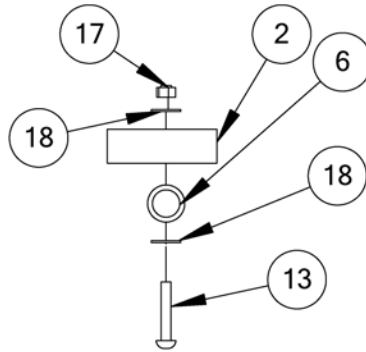

DETAIL C

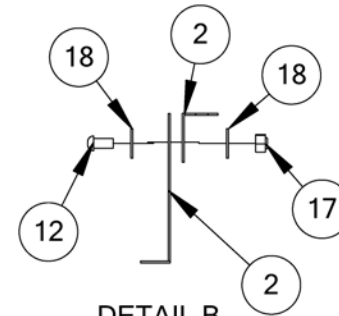

DETAIL B
TYP 2 PLS

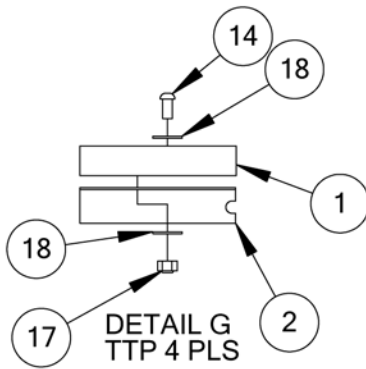

DETAIL G
TTP 4 PLS

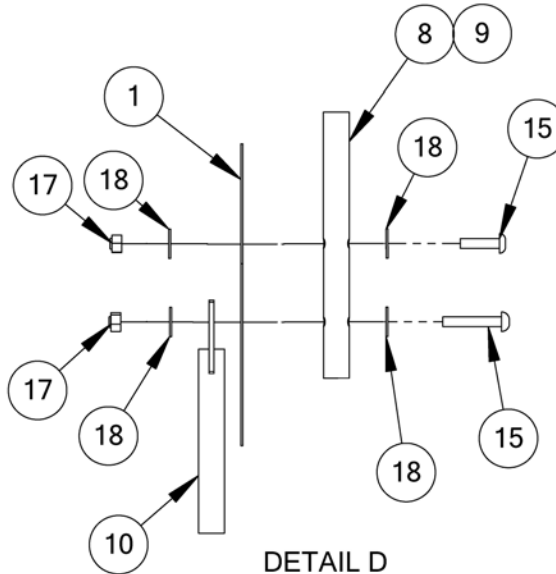

DETAIL D
TYP 2 PLS

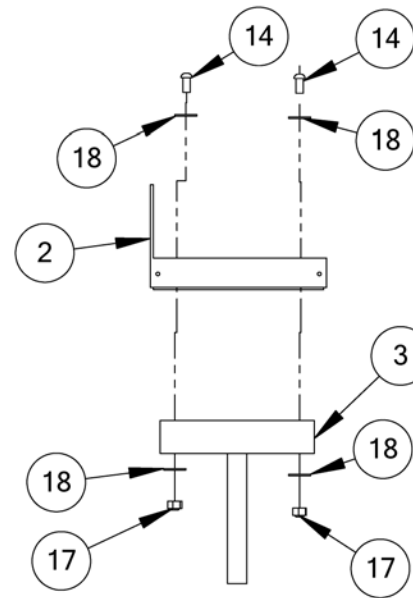

DETAIL E
TYP 2 PLS

Sheet 2 of 2

5 4 3 2 1

Transfer Station Plan:

The transfer station connects to a deck side. Consult the Top Down View for proper placement of the event.

INSTRUCTIONS:

1. First connect the bottom platform to the two-step assembly using (4) 3/8" X 1 3/4" button head bolts, (8) 3/8" washers, (4) 3/8" lock nuts.
2. Inside post supports (A+B), Handhold post (C), Short post (D). Center of A, B, C, D. A+B are 22" from deck posts, and C+D are 55 1/2" from the deck posts (on center).
3. Notice the "center line" (broken line): A+B are 14" left and right from the centerline. C+D are 12 1/2" left and right from the centerline.
4. Inside posts A+B are located outside the front of the transfer step bottom.
5. The (2) plank postholes are located by physically locating them, using the plank as a jig to locate (depending on whether plank will be on the right or left of the transfer deck.)
6. Lay out and mark (4) ground holes for posts #A, B, C, D by physically setting the transfer steps up to the deck, and use spray paint to mark the (4) holes.
7. Dig them 24" deep and 8" in diameter.
8. Loosely install these posts into their ground holes with re-bars in the bottom.
9. Connect the top of transfer step to deck (at the four hole locations on deck side) with (4) 3/8" X 1 3/4" button bolts, washer on both sides, and lock nuts under deck.
10. The bottom end of transfer step is blocked up vertically and horizontally on bubble.
11. Determine on which side the step plank will be located by viewing the Top Down drawing.
12. The handhold post will connect to the front step to the opposite side of the step plank.
13. Connect the transfer deck bottom front with (1) 3/8" by 3" button head bolt, washer both sides, and lock nut under the transfer deck.
14. Connect the short post (44" long) to the other side of front with same bolt connection through hole which is 2" from top of the short post.
15. Connect the left and right handrails to each side between the left and right deck posts to the vertical holes located on the corner of second step.
16. (2) pipe clamps, one per post, are installed on the "deck side" of posts at approx. 23 1/2" over the deck clamps.
17. Line up and bolt the bottom end handrails to outside of steps with (4) 3/8" by 3" button head bolts, washers and lock nuts under steps.
18. The bottom nut connection on each side will also connect to the 2" by 4" plate on the "inside post".
19. Connect plate to bottom bolts and level and adjust the inside posts.
20. Locate and match up the (2) holes in the top of angle plate, (connected to the step plank) to the holes on the left and right of the transfer step bottom. Hold the plank assembly there in order to spray paint the locations for the (2) angle/pipe ground holes (legs for plank assembly).
21. Dig these two holes 24" deep and 8" wide.
22. Connect the two angle/pipe legs to the plank (so the legs of angles are on the outside of plank) with (4) 3/8"

by 2" button bolts, washers on both sides, and (4) lock nuts underneath.

23. Install (2) re-bars in the bottom holes of these pipes.
24. Install the assembly into the ground holes, so that the top of the 27" angle plate matches to the holes in side of the bottom of the transfer assembly, and so your ground holes are correct so that they are on bubble and in middle of their holes etc.
25. Connect with (2) 3/8" by 1 1/4" button bolts, no washer on the outside and (2) 3/8" washer and lock nuts on underside of deck. Re-check levels of all (6) posts and the bottom plank and the entire transfer step. Make sure it is all level and blocked.

SPECIFICATIONS:

Event: Transfer Station shall be constructed of #9 gage by 3/4" flattened, expanded metal, including offset kickplates to fully enclose gaps between decks and steps.

Paint: Shall be oven-cured plastisol

Hardware: Stainless Steel tamper resistant

MAINTENANCE:

Touch up any marred paint surfaces.
Periodically check hardware for integrity and tightness.

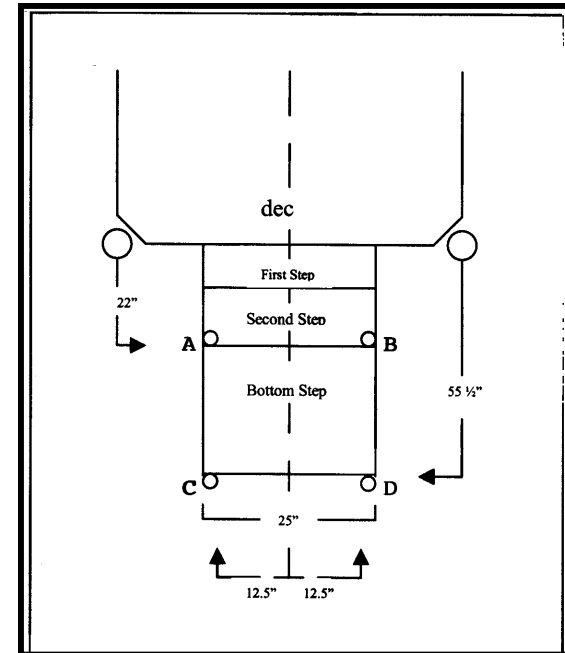

Kickplate

Item #	Part #	Part Description	Quantity
1	902-246	9" x 37" Kick plate	1
	902-247	12" x 37" Kick plate	
	902-249	26" x 37" Kick plate	
2	316-601	3/8" Flat Washer	16
3	126-701	3/8" x 1 1/4" Button head bolt	8
4	226-601	3/8" Lock Nut	8

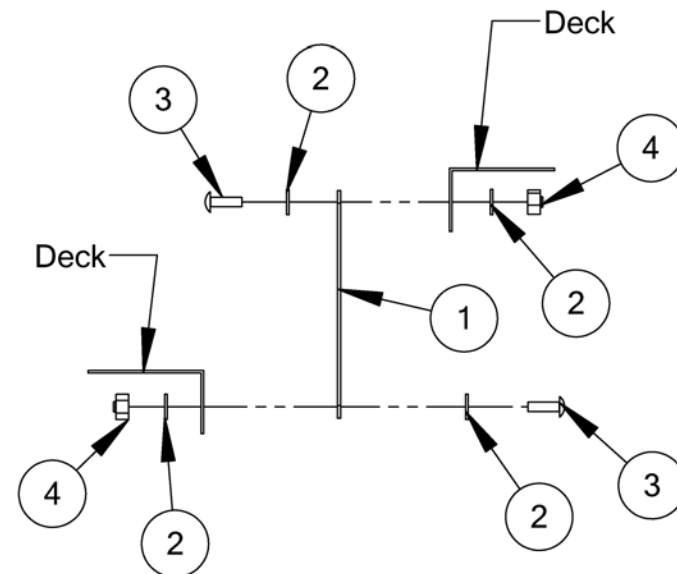
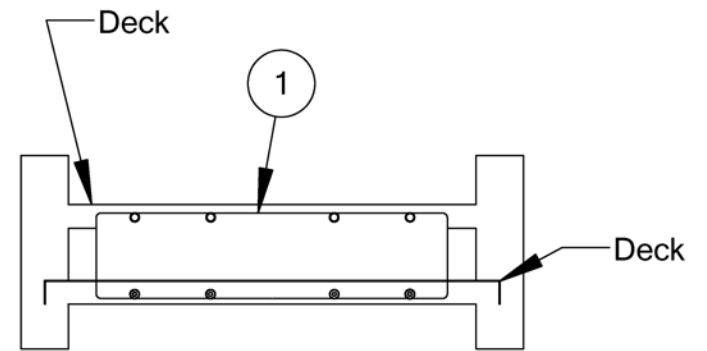

Kick Plate Plan:

Kick plates are installed to close the gaps created when decks rise in 'staircase' fashion.

INSTRUCTIONS:

- Kick plates are bolted to the FRONT of the higher deck and the BACK of the lower deck.
- Bolt kick plate to both decks.
- Insure that all hardware is tight.

SPECIFICATIONS:

Event: Kick plates are powdercoated.

Paint shall be electrostatically applied oven cured powdercoat.

Hardware: Stainless steel tamper resistant

MAINTENANCE:

Touch up any marred paint surfaces.

Periodically check hardware for integrity and tightness.

Triple Rail Slide

902-203,4

Item #	Part #	Part Description	Quantity
1	902-203 902-204	3' Triple Rail Slide 4' Triple Rail Slide	1
2	905-204	Connector Plate	1
3	903-103	48" Slide Guard	1
4	903-001	Pipe Clamp	4
5	903-214	T Legs	1
6	126-704	3/8" x 3" Button Head Bolt	2
7	126-702	3/8" x 3/4" Button Head Bolt	4
8	226-602	3/8" Nylon insert lock nut	6
9	316-601	3/8" Flat Washer	16
10	903-002	Deck clamp assembly	2
11		3/8" Zip toggle	4

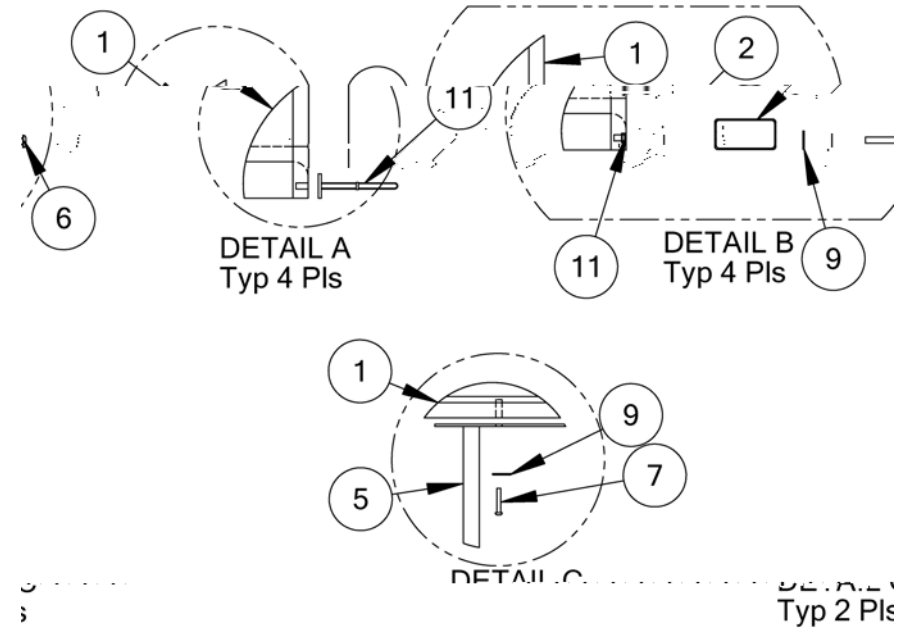

TABLE

Deck Height	Post/Footing Height
36"	49"
48"	88.5"

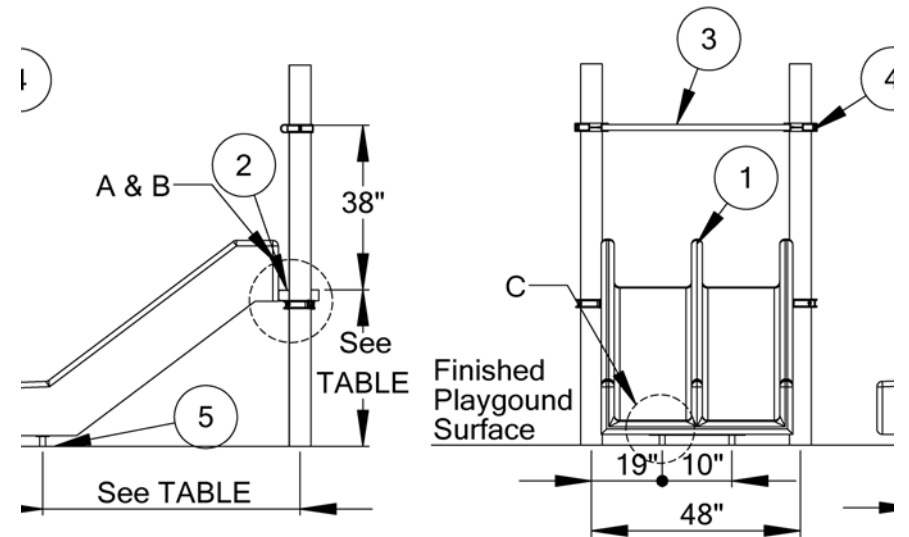

Triple Rail Slide Plan:

The Triple Rail Slide connects to the deck via a plastisol coated connector plate. The connector plate attaches to the top of the deck holes which are 15” apart on center. The slide legs are attached to the underneath of the exit end of the slide.

INSTRUCTIONS:

1. Mark 2 ground holes for the slide legs by placing the slide onto the deck, spray paint the ground to mark leg positions, and then remove the slide. (the legs are not attached to the slide yet)
2. Install the slide leg on the bottom of the slide with (3) 3/4” x 3/4” button head bolts. See Detail 3.
3. Install the slide with legs attached into the ground holes first, then to the deck.
4. Re-bar goes through the holes in the bottom of the legs.
5. The connector plate attaches to the deck when it is 90 degrees to the deck and any adjustments have been made to the ground holes.
6. It may be necessary to field drill the connector plate to the slide.
7. Connect top plate with (2) 3/8” x 1 1/4” button head bolts, no washer on top, and 3/8” washer and lock nut on bottom
8. Position the hand grab bars on either side of the slide so that the black plug end of each bottom spacer bar held by a pipe clamp butts up against the slide wall.
9. Make sure the grab bars are vertical, on bubble and no more than 3 1/2” from the support posts.

SPECIFICATIONS:

Event: Triple Rail Slide shall be constructed of 3/8” double wall construction has plastisol coated connector plate to deck with double slide legs and re-bar to ground. Has 2 slide beds with 4” high sidewalls. Comes with slide guard, post clamps and hardware.

Hardware: Stainless Steel tamper resistant

MAINTENANCE:

Touch up any marred paint surfaces.

Periodically check hardware for integrity and tightness.

Superficial scarring of the plastic can be ‘healed’ by gentle use of a heat gun or torch.

Rock Wall 3' ,4' , & 5' 902-273-3,-4,-5

ITEM NO.	PART NUMBER	DESCRIPTION	QTY.
1	902-273-3, 902-273-4, 902-273-5	Rock Climbing Wall	1
2	903-103	48" Pipe	1
3	000-000	Hand Holds	2
4	903-001	Pipe Clamps	2
5	196-807	3/8" x 3/8" Set Socket Screw	4
6	196-550	1/4" x 1/4" Roll Pin	4
7	236-601	3/8" T-Nut	8
8	316-601	3/8" Flat Washer	13
9	116-538	5/16" x 1-3/4"	1
10	216-512	5/16" x 1" Buttonhead Nut	1
11	226-602	3/8" Nylon Lock Nut	4
12	126-706	3/8" X 1-3/4" Buttonhead Bolt	8

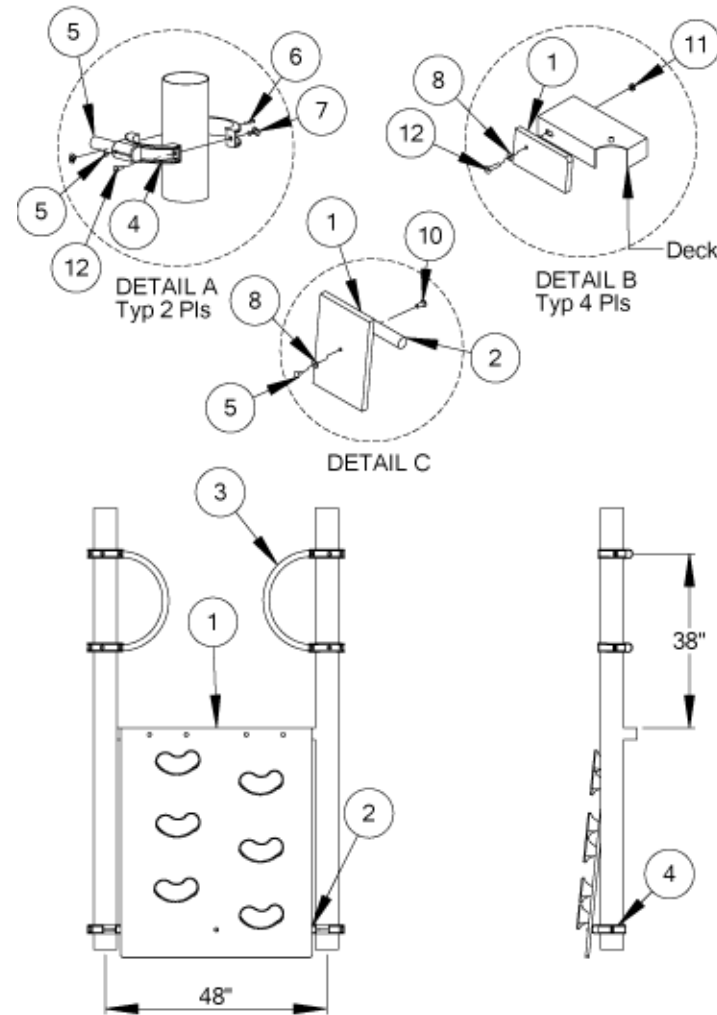

Rock Wall Plan:

The Rock Wall attaches to the side of a deck at the top and to 2 clamps and one pipe on the bottom.. See the Top Down View for placement.

INSTRUCTIONS:

- Begin by installing the rock wall to the side of the deck.
- Install the 2 pipe clamps and 1 48” pipe on the bottom.
- Attach the rock wall to the pipe.
- Finally attach the handholds.

SPECIFICATIONS:

Event: Rock wall is constructed of 3/4” polyethylene. Metal brackets are powdercoated.

Paint shall be electrostatically applied oven cured powdercoat.

Hardware: Stainless steel tamper resistant

MAINTENANCE:

Touch up any marred paint surfaces.

Periodically check hardware for integrity and tightness.

Panel Climber

902-267-3, 4', 5'

ITEM NO.	PART NUMBER	DESCRIPTION	QTY.
1	902-257	3' Panel Climber	1
2	903-206	Bracket for Plastic Panel	4
3	905-718	Deck Extension	1
4	903-001	Pipe Clamps	8
5	216-512	5/16" x 1" Buttonhead Nut	12
6	116-530	5/16" x 1" Buttonhead Bolt	12
7	326-501	5/16" Lock Washer	12
8	316-601	3/8" Washer	20
9	226-602	3/8" Nylon Lock Nut	4
10	226-602	3/8" x 1-1/4" Buttonhead Bolt	4
11	196-807	3/8" x 3/8" Socket Set Screw	8
12	126-706	3/8" x 1-3/4" Buttonhead Bolt	16
13	236-601	3/8" T Nut	16
14	196-555	1/4" x 3/4" Roll Pin	8

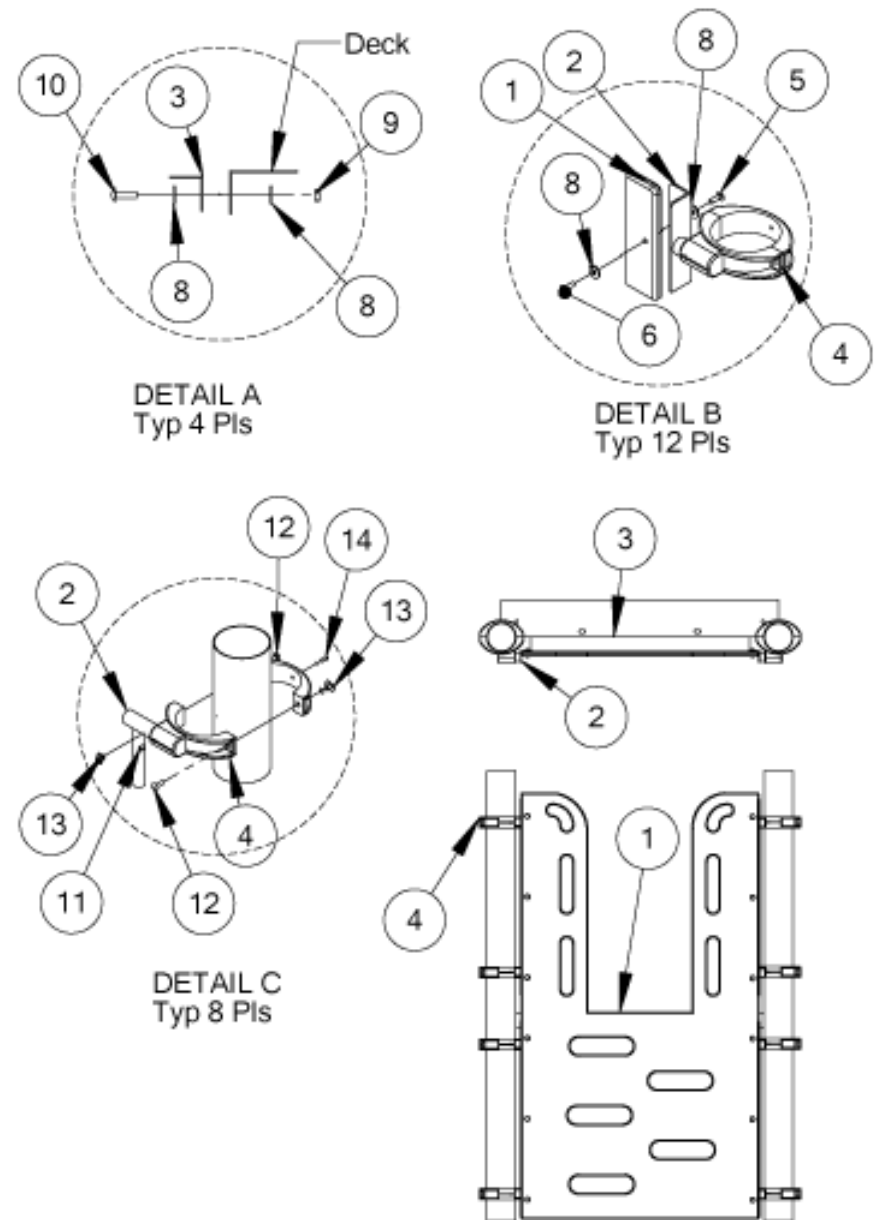

Panel Climber Plan:

The Panel Climber attaches to the posts via 8 pipe clamps and 4 brackets. See the Top Down View for placement.

INSTRUCTIONS:

- First install the deck extension to the side of the deck as shown in Detail A. Level and tighten.
- Next install the four angle brackets to the climber. There will be two per side, one will go above the deck and the other will go below the deck. You may find it easier to attach the pipe clamps to the posts as shown above and then insert the brackets into them. Then this will allow you to mount the brackets and pipe clamps so they do not interfere with any other component.
- Once location has been determined, hold climber up against the brackets and mark the holes. The top of the entrance cutout should be even with the deck extension.
- Drill and mount the panel climber as shown in detail B.

SPECIFICATIONS:

Event: Bus Panel is fabricated of ¾" polyethylene. Metal brackets are powdercoated.

Paint shall be electrostatically applied oven cured powdercoat.

Hardware: Stainless steel tamper resistant

MAINTENANCE:

Touch up any marred paint surfaces.
Periodically check hardware for integrity and tightness.

Zig Zag Loop Climber

902-112

ITEM NO.	PART NUMBER	DESCRIPTION	QTY.
1	902-112	Zig Zag Loop Climber	1
2	903-005	48" Pipe	2
3	903-001	Pipe Clamps	4
4	196-807	3/8" x 3/8" Set Sock	8
5	126-706	3/8" x 1 1/4" Button Bolt	8
6	196-555	1/4" x 3/4" Roll Pin	14
7	236-601	3/8" T-Nut	8

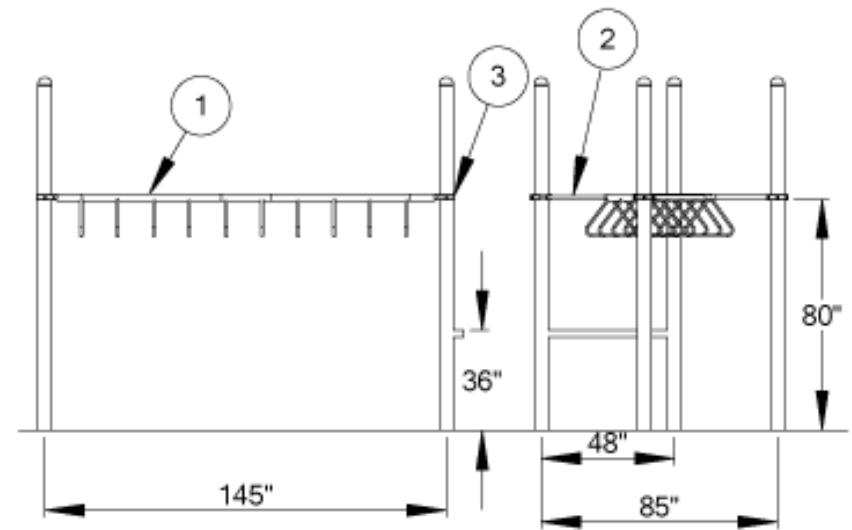
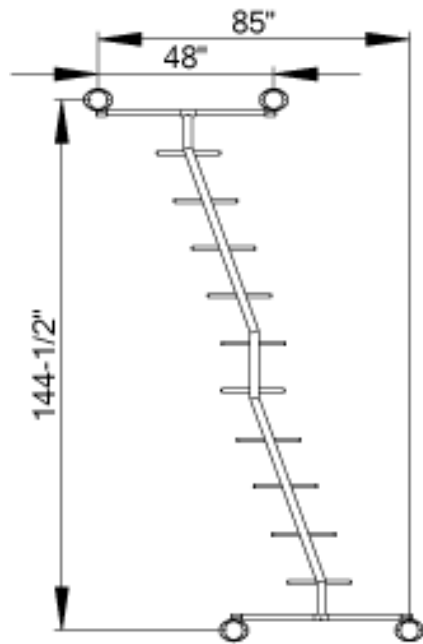
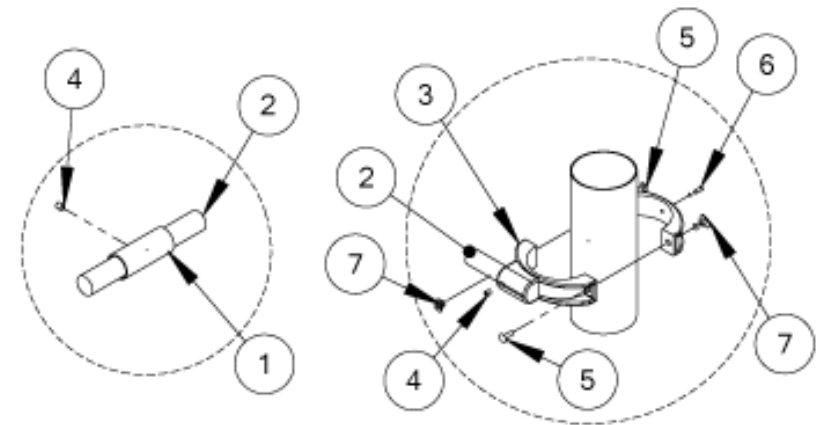

Zig Zag Loop Climber Plan:

The Zig Zag Climber attaches above a deck or stand alone to the outside of the posts with 4 pipe clamps. See the Top Down View for post placement.

INSTRUCTIONS:

- Install the zig zag on the outside of the posts, see top view.
- Insert the (2) 48" pipes into the sleeve on each end, center them and lock down with the 3/8" set screws.
- Place one pipe clamp on any of the 4 large structure posts at a height of 80" from the top of the safety surfacing to the bottom of the clamp. Tighten clamp. Install a second clamp on the other post on that end but do not tighten it.
- Lift one end of the climber and insert pipe into pipe clamp. Slide the other loose clamp up to the other end of the pipe and insert this pipe end into it, level and tighten clamp. Do not tighten set screw at this time.
- Install a third pipe clamp on one of the remaining two posts on the opposite end at the same height (due to ground variations you will probably need to level the climber after climber is in place).
- With the help of another person, raise the other end of the climber and insert into the installed pipe clamp. Now check for level and adjust as needed.
- Finally install the final pipe clamp and make sure the climber is centered between the posts and tighten all set screws.

SPECIFICATIONS:

Event: Mirror is constructed of 1/8" thick poly carbonate with silver backing attached to a 3/4" polyethylene panel. Metal brackets are powdercoated.

Paint shall be electrostatically applied oven cured powdercoat.

Hardware: Stainless steel tamper resistant

MAINTENANCE:

Touch up any marred paint surfaces.

Periodically check hardware for integrity and tightness.

Chain Net Climber

902-408, -09, -10

Item #	Part #	Part Description	Quantity
1	902-402	Chain Net 3'	1
	902-410	Chain Net 4'	
	902-415	Chain Net 5'	
2	902-408	Top Angle Plate	1
3	903-409	Chain Net Bottom Plate	1
4	903-126	Small Handhold	2
5	903-001	Pipe Clamp	4
6	558-901	3/8" "S" Hook	8
7	126-701	3/8" x 1 1/4" Buttonhead bolt	2
8	316-601	3/8" Washer	2
9	226-601	3/8" Lock Nut	2

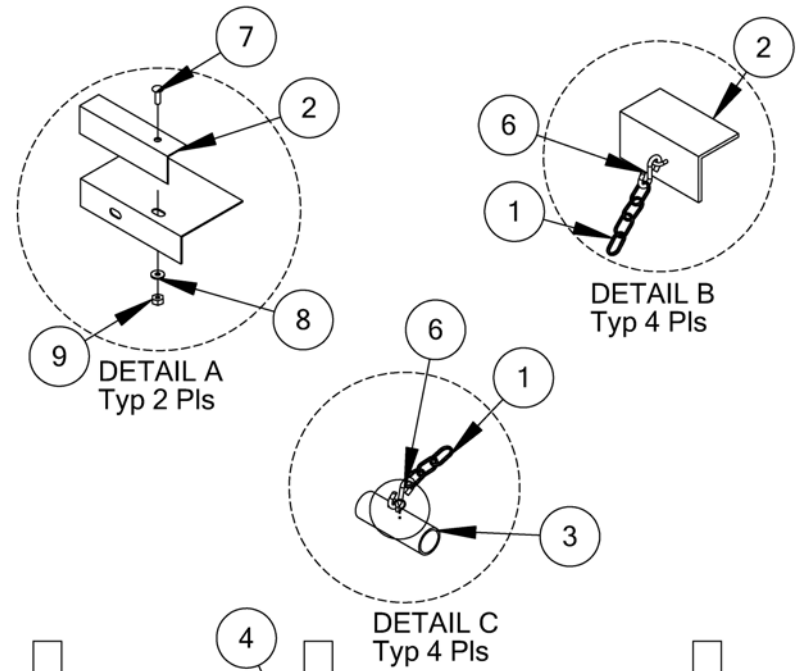

TABLE

Deck Height	Post/Footing Distance
36"	32"
48"	32"
60"	62"

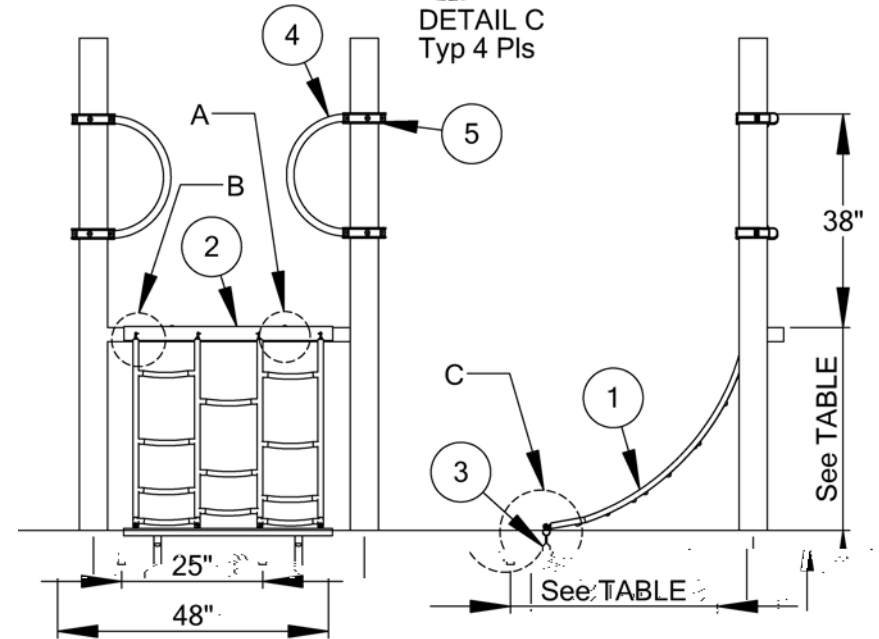

Chain Net Climber Plan:

The Chain Net Climber attaches at deck level and is secured at ground level. Separate handholds are included. See the Top Down View for placement.

INSTRUCTIONS:

- Install the top angle to the deck using hardware listed in Detail A.
- Attach the S hooks to the chain net climber, then to the top angle plate according to Detail B. Make sure to close S hooks to no greater gap than 3/16”.
- Use the chain net as a template to mark the position of the bottom plate on the ground. The chain net should be installed at least 32” out from the deck. The net should have a slight dip in it.
- Dig holes 24” deep.
- Set the bottom angle feet in the cement, keeping the angle flush on the ground so it will not be a trip hazard. Eye bolts must be below the required depth of resilient surfacing. Bolt heads face out toward the climber. The threaded end is on the underside of the net.
- After cement hardens, attach the bottom of the chain net to the bottom angle with S hooks. Make sure to close S hooks to no greater gap than 3/16”.

SPECIFICATIONS:

Event: chain net is plastisol coated 4/0 galvanized chain.

Paint shall be electrostatically applied oven cured powdercoat.

Hardware: Stainless steel tamper resistant

MAINTENANCE:

Touch up any marred paint surfaces.
Periodically check hardware for integrity and tightness.

Guard Wall

902-135-W

Item #	Part #	Part Description	Quantity
1	913-117-W	Guard Wall /fitting	1
2	903-001	Clamps	4
3	196-807	3/8" x 3/8" Socket Set Screw	4
4	196-550	1/4" x 3/4" Roll Pin	4
5	236-601	3/8" T-Nut	8
6	126-706	3/8" x 1 3/4" Button Head Bolt	8

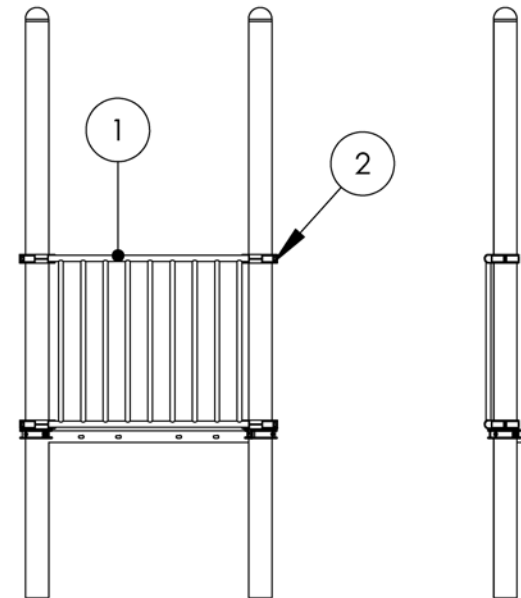
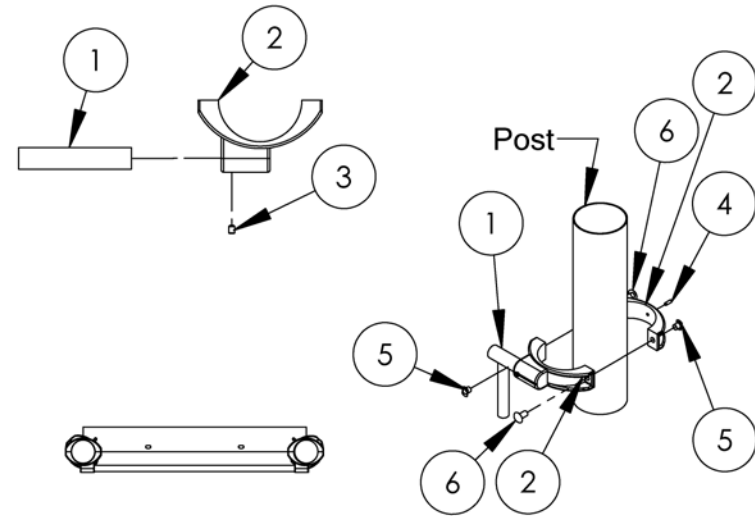

Guard Wall Plan:

The 10 Rung Guard Wall attaches above the deck to the “deck side” of the posts with 4 post clamps. There is a mounting plate for the Steering Wheel that will be attached later.

INSTRUCTIONS:

- Install the wall on the “deck side” of the posts.
- Install with the centered welded bracket toward the top
- Install with no more than 3 1/2” between the bottom of the wall and the top of the deck
- It is helpful to install with a couple of equal size shims under the wall to help hold the wall in position
- Review the clamp instructions for sideways attachment of clamps.

SPECIFICATIONS:

Event: the 10 Rung Guard Wall is 48” wide and acts as a barrier to prevent falls from decks. Horizontal pipes that fit into post clamps are 1 3/8” OD. Vertical pipes are 1” OD.

Paint shall be electrostatically applied oven cured powdercoat.

Hardware: Stainless steel tamper resistant

MAINTENANCE:

Touch up any marred paint surfaces.
Periodically check hardware for integrity and tightness.

Steering Wheel 902-114

Item #	Part #	Part Description	Quantity
1		Welded wheel fitting	
2	905-117	Steering Wheel	1
3	902-135-W	Guard Wall with welded wheel fitting	1
4	116-600	1/2" x 1/2" Button Head Bolt	1
5	316-801	1/2" Flat Washer	5
6	226-802	1/2" Nylon Lock Nut	1

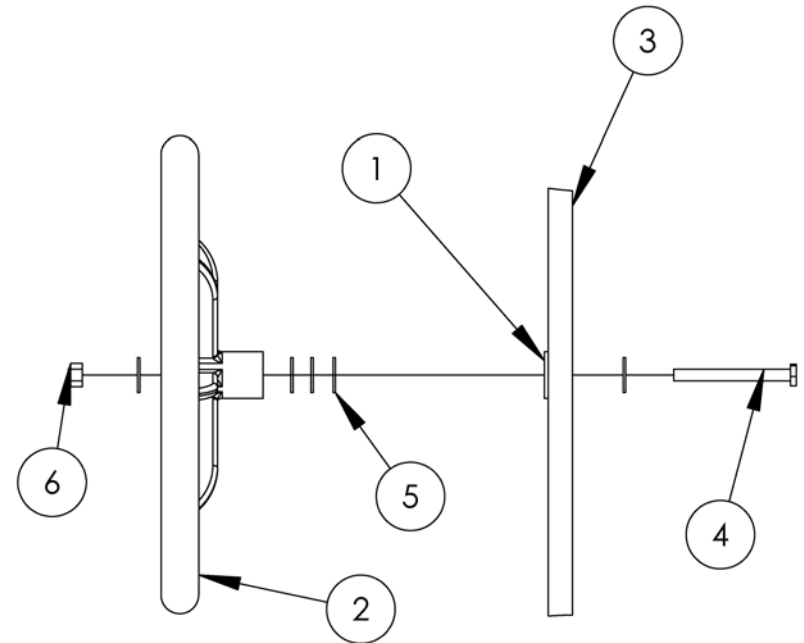
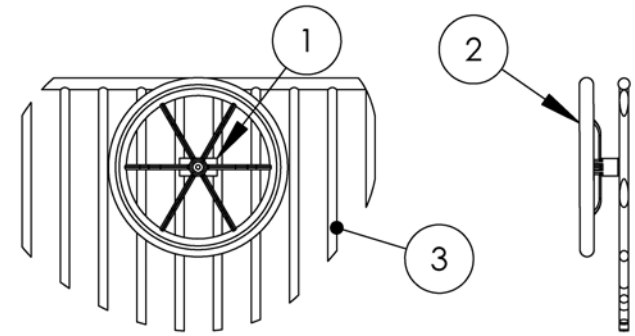

Steering Wheel Plan:

The Steering Wheel attaches to the 10 Rung Guard Wall onto the welded bracket.

INSTRUCTIONS:

- Place the 1/2" lock nut **INSIDE** the wheel so as not to create a protrusion.
- Place one washer between the bolt head and the plate
- Place three washers between the wheel and plate
- Place one washer inside the wheel under the lock nut
- Tighten the nut
- The wheel should be tight, but yet still able to turn
- Snap on the cover over the bolt assembly

SPECIFICATIONS:

Event: Steering Wheel shall be constructed of a polycarbonate 12" diameter wheel countersunk wheel hub connects to wall with non-slip double plate, center 1/2" bolt and lock nut.

Hardware: Stainless steel tamper resistant

MAINTENANCE:

Periodically check hardware for integrity and tightness.

Tic Tac Toe Panel

902-121

Item #	Part #	Part Description	Quantity
1	903-121	Tic Tac Toe Panel	1
2	903-001	Post Clamp	4
3	196-807	3/8" x 3/8" Socket Set Screw	4
4	196-555	1/4" x 3/4" Roll Pin	4
5	236-601	3/8" T Nut	8
6	126-706	3/8" x 1 3/4" Button head bolt	8

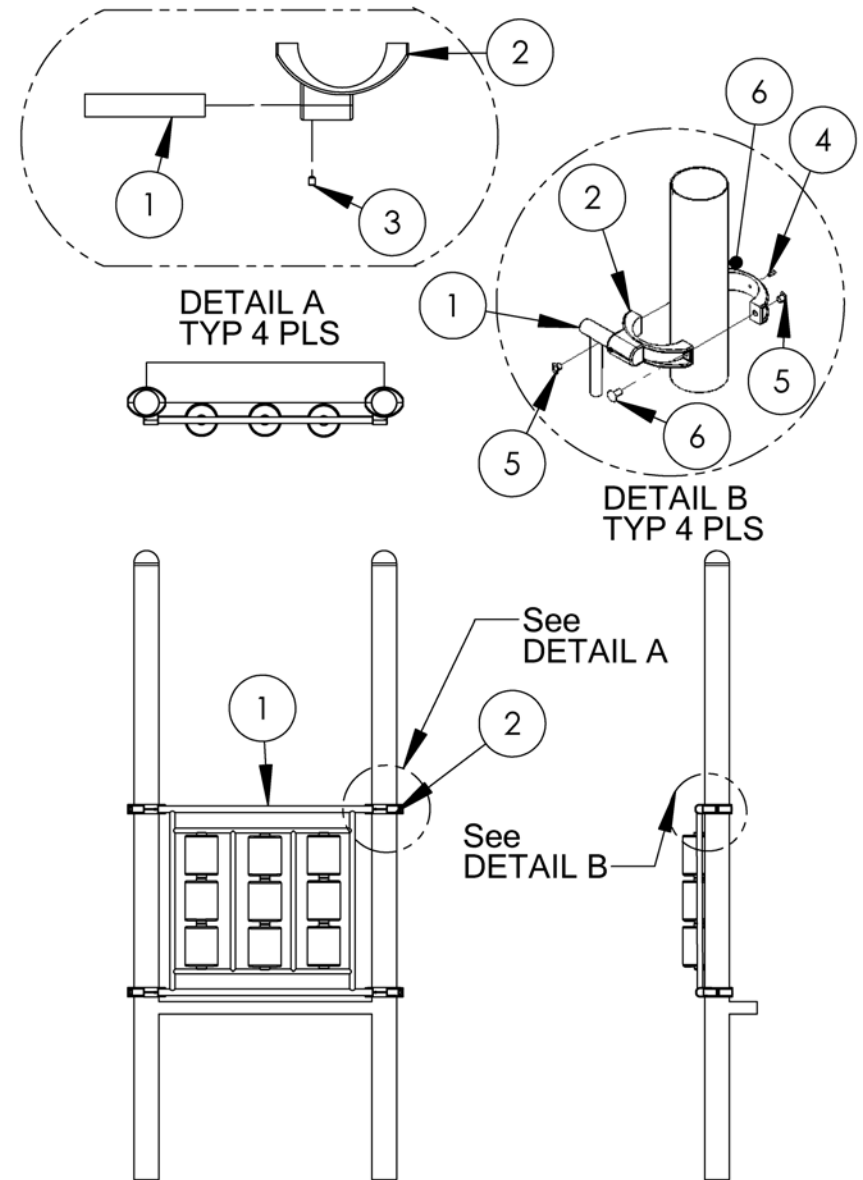

Tic Tac Toe Panel Plan:

The Tic Tac Toe Panel attaches above or below the deck to the “deck side” of the posts with 4 post clamps. See 2d Top Down view for proper placement.

INSTRUCTIONS:

- Install the wall on the “deck side” of the posts
- Install with the centered welded bracket toward the top
- Install with no more than 3 1/2” between the bottom of the wall and the top of the deck
- It is helpful to install with a couple of equal size shims under the wall to help hold the wall in position
- When the unit is installed on bubble, equally space the spacer bars on each side between the posts using the allen wrench

SPECIFICATIONS:

Event: Tic Tac Toe Panel shall be constructed of cylindrical blocks with silkscreen letters are held by 7/8” OD pipe. Event is 48” wide and attaches with four pipe clamps.

Paint shall be electrostatically applied oven cured powdercoat.

Hardware: Stainless steel tamper resistant

MAINTENANCE:

Touch up any marred paint surfaces.

Periodically check hardware for integrity and tightness.

Bump Wave Slide 902-284, 5, 6

Item #	Part #	Part Description	Quantity
1	435-609	Bump Wave Slide 4'	1
	435-607	Bump Wave Slide 5'	
	435-608	Bump Wave Slide 6'	
2	913-115	Slide Guard	1
3	903-214	Slide T Leg	2
4	903-001	Pipe Clamp	4
5	903-141	Z Plate (installed on slide)	1
6	126-701	3/8" X 1 1/4" Button head bolt	2
7	316-601	3/8" Flat Washer	11
8	226-602	3/8" Lock Nut	2
9	196-555	1/4" x 3/4" Roll Pin	4
10	196-807	3/8" x 3/8" Socket Set Screw	4
11	126-706	3/8" x 1 3/4" Button head bolt	8
12	236-601	3/8" T-Nut	8
13	126-702	3/8" x 3/4" Button head bolt	7

TABLE A:

Deck Height	Post/Footing Distance
48"	72"
60"	95.5"
72"	113"

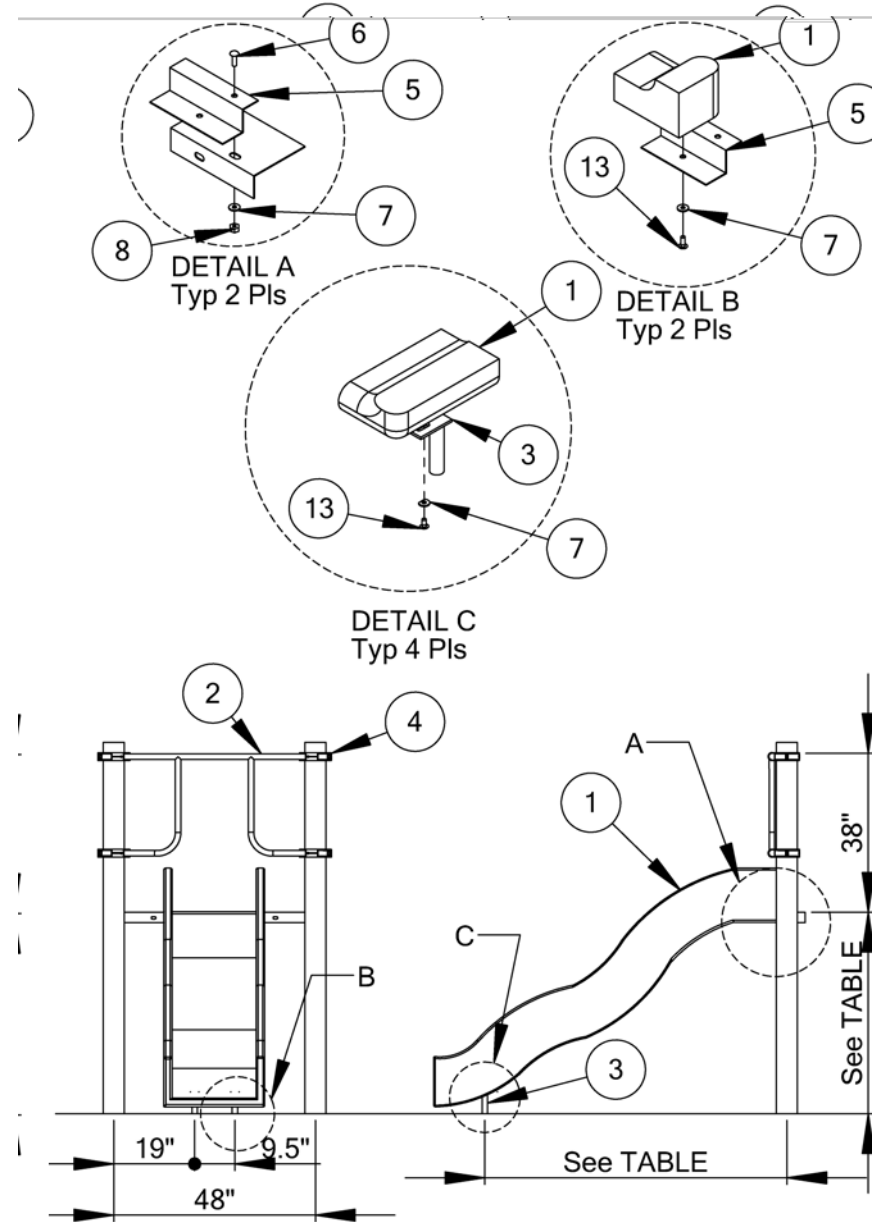

Bump Wave Slide Plan:

The Bump Wave Slide attaches to the deck by bolting through the Z plate and the deck sidewall. See the Top Down View for placement.

INSTRUCTIONS:

- Underneath the ‘foot’ of the slide, there are two sets of threaded inserts into which the slide legs attach.
- Using your slide as a template, mark the ground holes for the slide legs making sure that the holes in the Z plate are aligned with the holes in the deck and the A plate is at a 90 degree angle to the deck. Prop the ‘foot’ of the slide up and mark hole locations.
- Dig one hole for both legs 12” wide by 20” long and 24” deep.
- Connect the slide legs to the threaded inserts with four 3/4” x 3/8” button head bolts.
- Place the bottom end of the slide with installed legs and re-bars through the hole in the bottom of the slide legs into the ground.
- Carefully tip the top of the slide back onto the deck.
- Make sure you ream the vinyl coated holes out (15” apart) with a 1/2” metal bit.
- Connect the Z plate to the deck with two 3/8” x 1 1/4” button head bolts, no washer on top, and 3/8” washer and lock nut on the bottom. (Normally, this is already assembled)
- Place a level over the bottom to be sure it is on bubble, block and level.

- Install the slide guard and four clamps over the deck entry on the “deck side” so that the top of the guard is approximately 38” above the deck.

SPECIFICATIONS:

Event: Bump Wave Slide is 3/8” wall, rotationally molded, 24” wide slide bed with 6” high side rails. Metal brackets are powdercoated.

Paint shall be electrostatically applied oven cured powdercoat.

Hardware: Stainless steel tamper resistant

MAINTENANCE:

Touch up any marred paint surfaces.

Periodically check hardware for integrity and tightness.

Corkscrew Climber

902-133-3, -4, -5

Item #	Part #	Part Description	Quantity
1	903-137	Arch Wall	1
2	903-133-3 903-133-4 903-133-5	Corkscrew Climber 3' Corkscrew Climber 4' Corkscrew Climber 5'	1
3	903-001	Pipe Clamp	4
4	196-555	1/4" x 3/4" Roll Pin	4
5	196-807	3/8" x 3/8" Socket Set Screw	4
6	236-601	3/8" T Nut	8
7	126-706	3/8" x 1 3/4" Button head bolt	8
8	116-535	5/16" x 1 1/2" Button head bolt	1
9	326-501	5/16" Lock Washer	1
10	216-512	5/16" X 1" Button head nut	1

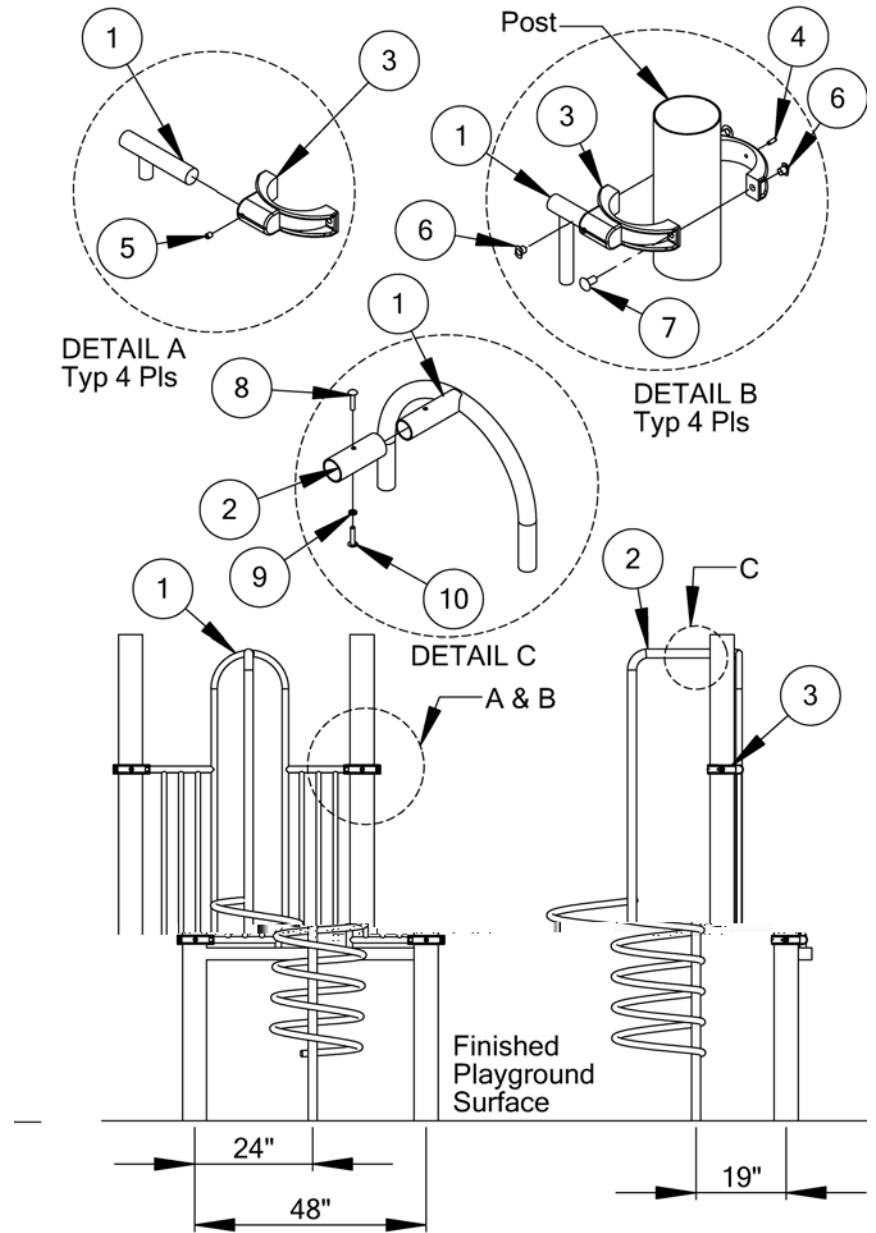

Corkscrew Climber Plan:

The Corkscrew Climber attaches to the deck from an arch wall.

INSTRUCTIONS:

- Install the arch wall on the “deck side” of the posts with pole attachment stub facing outward.
- Attach the Corkscrew Climber to the arch wall. (See detail C) Be sure to maintain the same width between the top and bottom of the arch entry opening.
- Make sure all gaps (between walls and posts and deck) are less than 3 1/2”.
- Install Corkscrew Climber 19” out from the deck.

SPECIFICATIONS:

Event: Corkscrew Climber is constructed of Type #4 steel welded to 24” diameter by 1 5/8 O.D. coil. Angle plate connects to deck. 1” outer diameter handholds are welded to support.

Paint shall be electrostatically applied oven cured powdercoat.

Hardware: Stainless steel tamper resistant

MAINTENANCE:

Touch up any marred paint surfaces.
Periodically check hardware for integrity and tightness.

Bubble Panel

902-117

Item #	Part #	Part Description	Quantity
1	435-665	Bubble panel	1
2	903-001	Pipe Clamp	4
3	903-309	Spacer Bar (preinstalled)	2
4	903-103	Panel Support (preinstalled)	2
5	196-807	3/8" x 3/8" Socket Set Screw	8
6	196-555	1/4" x 3/4" Roll Pin	4
7	236-901	3/8" T-Nut	8
8	126-706	3/8" x 1 3/4" Button head bolt	8

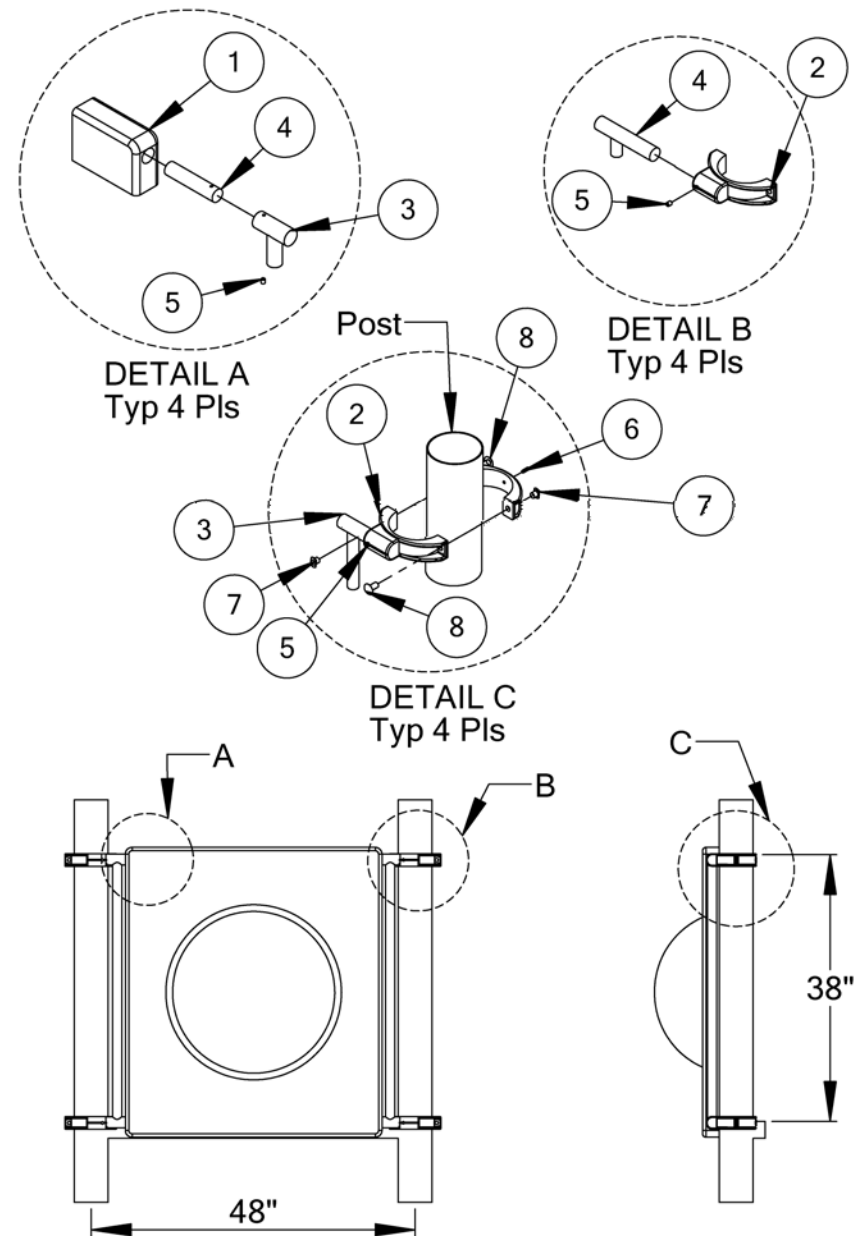

Bubble Panel Plan:

The Bubble Panel attaches above or below the deck to either the “deck side” or the outside of the posts with 4 post clamps. See the Top Down View for placement.

INSTRUCTIONS:

- DECK SIDE OF POSTS - Install the panel on the “deck side” of the posts making sure the gap between the panel and the deck does not exceed 3 1/2”.
- OUTSIDE POSTS – Install the panel on the outside of the posts making sure the gap between the panel and deck does not exceed 3 1/2”.
- If installing to an above deck position, install the bottom clamps first. If installing to a below deck position, install the upper clamps first. (See Detail B) Install with *no more* than 3 1/2” between the panel and the nearest edge of the deck. Installation above or below deck requires the same distance between the wall and deck. This measurement is *CRITICAL* for the safety of the users.
- Install the panel to the clamps. (See Detail A and C). Center the panel between the posts. The bubble faces OUT or away from the deck. To center, adjust the vertical spacer bars between the posts and panel by adjusting the set screws.
- It is helpful to install with a couple of equal size shims under the panel to help hold the wall in position

SPECIFICATIONS:

Event: Bubble is constructed of clear lexan and is bolted to the panel with stainless steel hardware. Metal brackets are powdercoated.

Paint shall be electrostatically applied oven cured powdercoat.

Hardware: Stainless steel tamper resistant

MAINTENANCE:

Touch up any marred paint surfaces.

Periodically check hardware for integrity and tightness.

5' Sectional Slide 902-216

ITEM NO.	PART NUMBER	DESCRIPTION	QTY.
1	000-000	Curved Sectional Slide 5'	1
2	903-011	Pipe Clamps	2
3	903-214	"T" Leg	2
4	903-215	Bracket for Sectional Slide	2
5	226-602	3/8" Nylon Lock Nut	9
6	316-601	3/8" Flat Washer	24
7	196-807	3/8" x 3/8" Socket Set Screw	2
8	126-706	3/8" x 1-3/4" Buttonhead Bolt	4
9	236-601	3/8" T-Nut	4
10	196-555	1/4" x 3/4" Roll Pin	2
11	116-618	3/8" x 4-1/2" Hex Bolt	5
12	126-709	3/8" x 2-1/2" Buttonhead Bolt	2
13	516-200	3/8" Toggler	4
14	116-608	3/8 x 2" Buttonhead Bolt	2
15	126-702	3/8" x 3/4" Buttonhead Bolt	4

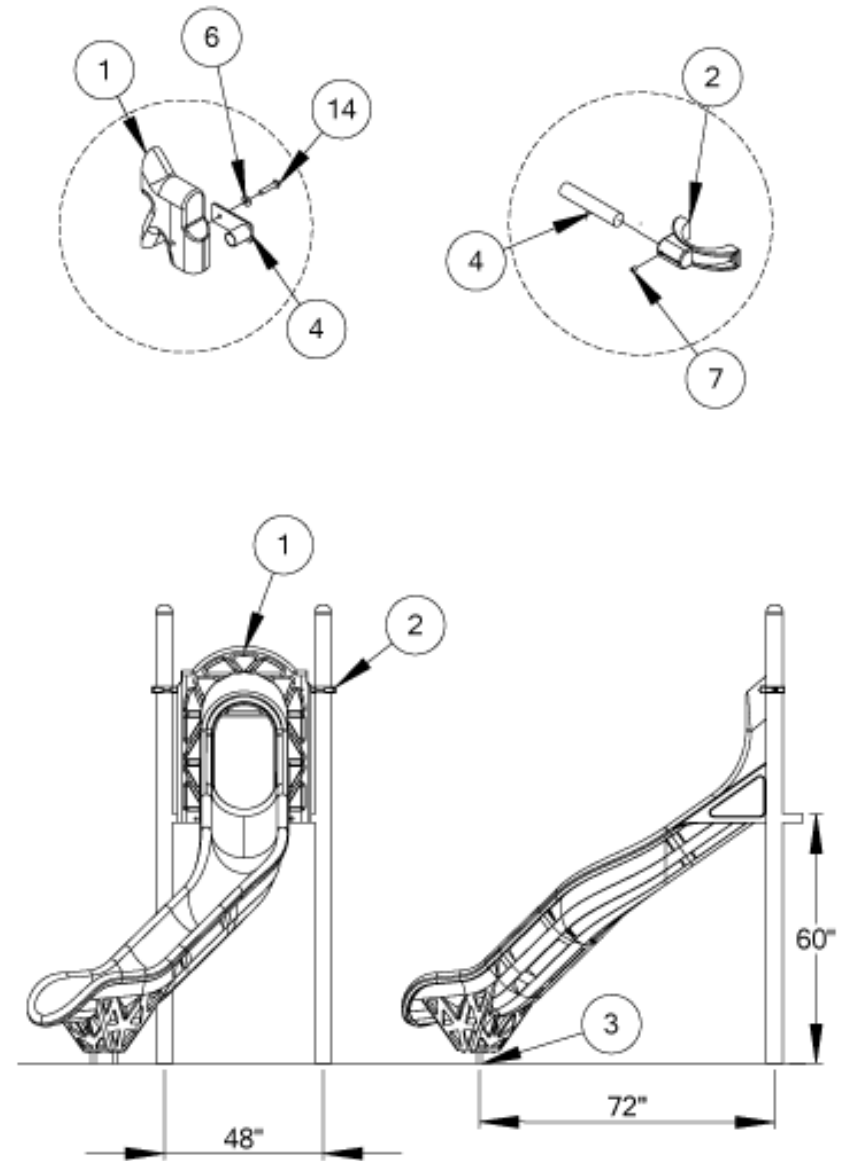

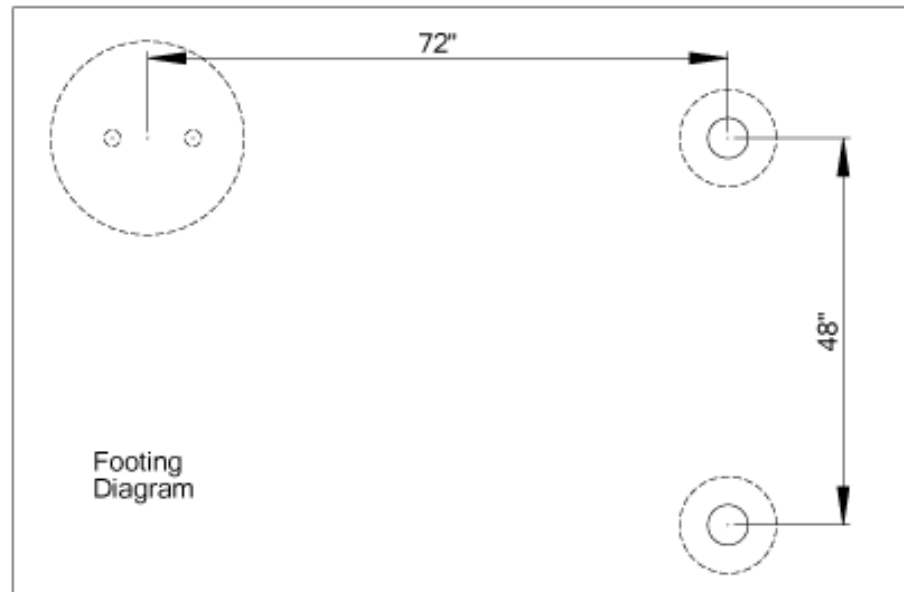
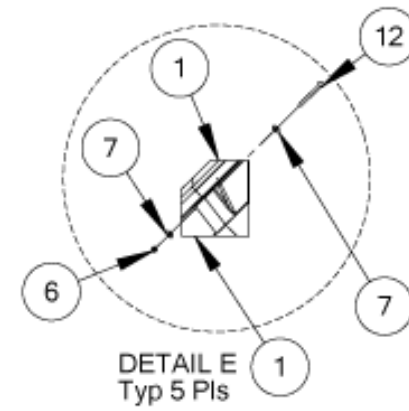
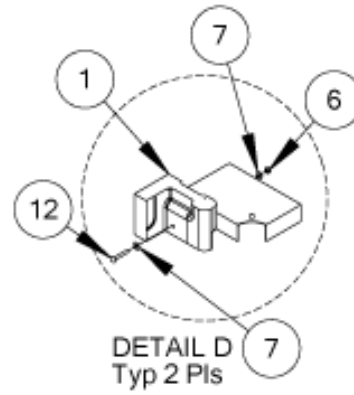
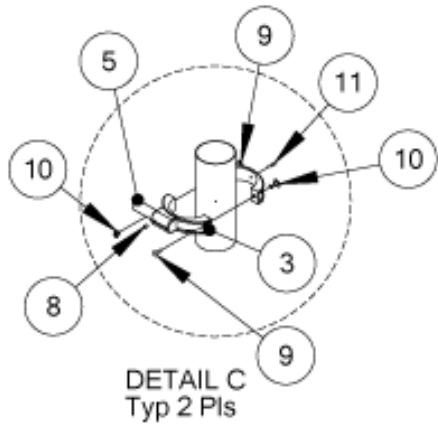

5' Sectional Slide Plan:

The spiral slide attaches to the main structure deck via bolts through the slide and two brackets and two clamps on top.

INSTRUCTIONS:

- Begin by marking the one footing by using the footing layout above. Dig the hole 24" in diameter and 24" deep, this one hole will be used for both bottom support legs.
- Now assemble the two slide pieces together as shown in Detail E and tighten.
- Next install the slide to the deck, this will require at least 1 other person. Raise and let rest on the deck, mark the two outside holes and drill. Install hardware as shown in Detail D.
- Attach the two brackets as shown in Detail A. Then attach pipe clamps and tighten.
- Finally level slide and make sure that water will drain out of bedway and then concrete.
- Allow concrete to fully cure before allowing play.

SPECIFICATIONS:

Event: Slide is rotationally molded and deck is plastisol coated.

Paint shall be electrostatically applied oven cured powdercoat.

Hardware: Stainless steel tamper resistant

MAINTENANCE:

Touch up any marred paint surfaces.
Periodically check hardware

Label Installation

Apply to clean, dry, smooth surface. Carefully peel label from paper backing and apply with no wrinkles or tears. Install them where they will not be disturbed during play. Inspect labels regularly. If torn, disfigured, damaged or faded, contact your SportsPlay distributor for replacement labels.

Top of Surfacing Label

Install one to each upright post at the level you have determined will be your "Top of Surfacing" based on fall height and resilient surfacing used.

Warning Label

Install two labels at eye level to different upright posts at locations most likely to be used to access the play unit.

Manufacturer Label

Install labels at eye level to posts near the Warning Labels.

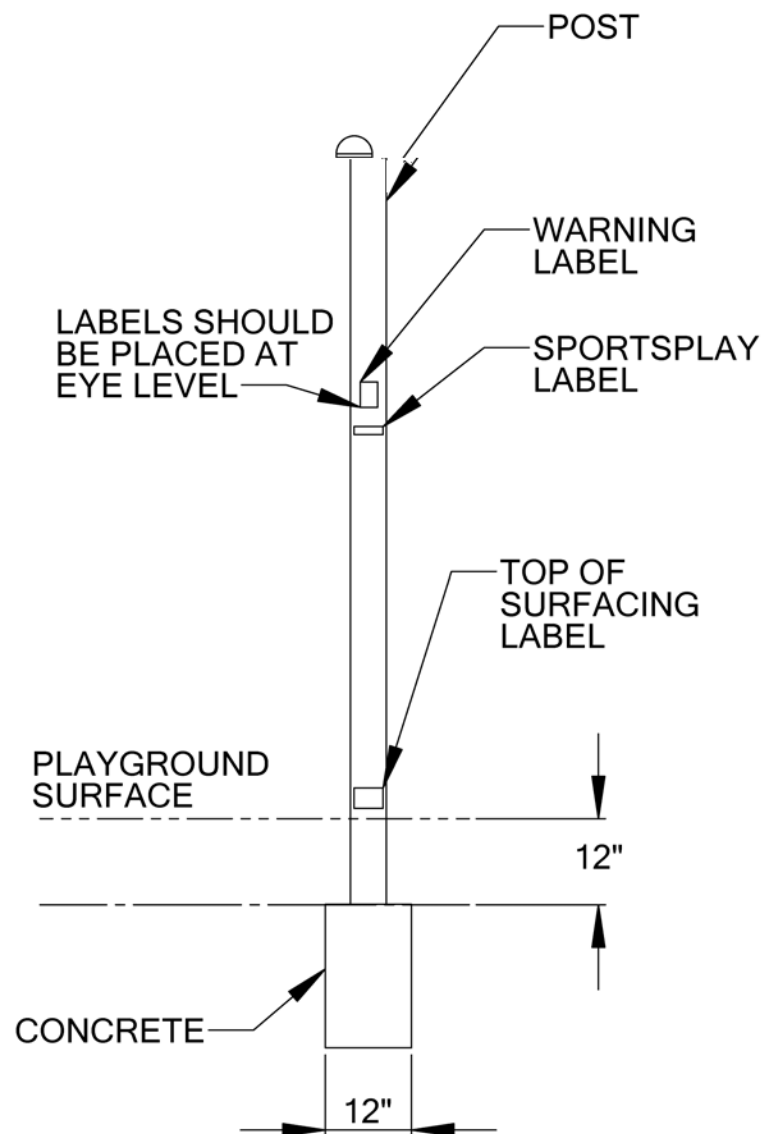

Trouble Shooting

Problem: Incorrect sized hole or no hole where there is supposed to be one.

Solution: Use a 1/4" leader drill bit to drill a hole at the desired location. Next, drill larger size hole with correct bit. Usually, when there is a hole missing, it is an oversight, but if it appears that there are several missing holes, re-check your work.

Problem: Setscrew missing on clamp or setscrew hole is cross-threaded.

Solution: Drill a new hole in the clamp at the correct location with a 5/16" bit, then tap with a 3/8"/16 tap.

Problem: A typical 48" long portion of a pipe will not fit correctly, causing the posts to be off level.

Solution: First, check to see that the pre-installed setscrews are not installed too far into the clamp making it impossible for the pipe to enter the clamp. Also, make sure that the clamp is not crooked, preventing the pipe ends to enter the clamp all the way. If this is the case, install clamp sideways onto pipe, then attach to post. The pipes enter the clamp a distance of 1 1/4" deep. If the pipe does not enter all the way, then use a rubber hammer to pound a component to the left or right to ensure the pipe ends have dead-ended into clamps. If the problem remains, contact your distributor.

Problem: A clamp has already been drilled and has had a roll pin installed and you have to move it.

Solution: Using a punch, simply knock the roll pin through the clamp and post then move the clamp.

Problem: There is interference between a vertical portion of one component and another vertical portion of another component going into the opposite direction. (For instance, in the case of a tunnel or bubble window that has a vertical spacer bar).

Solution: Loosen the spacer bar by loosening the setscrew on it, move it over to make room.

Problem: Your posts are out of line.

Solution: Unblock your new posts. Check to see if when the deck was installed the posts were not on the center to the corners of the deck. Loosen the hardware and re-line the posts this way. In most cases, you have to back up, loosen hardware, and physically move each post or component that is connected similarly with 48" end pipes. There is a chance that the component was installed so that it was out of center of the 48" posts, which connect it. Loosen the setscrews on these parts; move them back into line, re-block posts. You must work hard to insure that posts are in line and on bubble.

Problem: You try to level a part or post and it won't budge, it swings or else bounces back.

Solution: Your hardware or blocks are too tight. Loosen the assembly, level and then re-block and re-tighten.

Problem: Bolt size in parts box does not match the instructions for the bolt.

Solution: If we made an error in sending the wrong hardware, use a correct size from the hardware store and we'll reimburse you.

Safety Checklist

Carefully go over each post, deck and component with bare hands very carefully to detect any areas that may be sharp. During installation and handling, there may be areas that were hammered; causing rough areas that may be sharp. Use the following list to check for problem areas:

- Scrapes in metal pieces. Use steel wool, files or sandpaper to smooth.
- Spatter or burrs at all welded locations. Look closely and smooth.
- Scratches on the plastic parts. Look closely and smooth with steel wool.
- Edges and mold lines on plastic and aluminum parts should be smoothed with steel wool or files.
- Slide connection joints, smooth and fill if necessary with outdoor clear caulk sealant. This applies to any small opening that might be a “catch” or entanglement point.
- Sleeve ends, sometimes rough handling will cause rough edges. Sand down rough areas if they exist. Check that screws are seated.
- Vinyl coated parts, check all areas to de-burr.
- Roll pins; make sure they are flush and to not stick out.
- Clamps, when aluminum is hammered, it can cause a rough area. De-burr if necessary.
- Bolt thread protrusions, two threads are maximum protrusion allowed. If more than two threads are visible, cut off and file smooth.
- “T” nuts, should not stick out. Loosen and retighten.
- Black top end caps, smooth down rough areas as necessary.
- If there are any nail or screw heads which are improperly installed (bent or marred) remove and replace.
- Angle irons, check all corners for rough areas – sand if necessary.
- Set Screw, all setscrews should be flush with metal surfaces. Check all and tighten.
- Exposed concrete – all concrete should be poured below grade. Backfill all of the footings with dirt.
- Never ASSUME that hardware was tightened. Check everything.
- Touch up painted areas as needed.

Photo Appendix

Explosion drawings are included throughout the instructions. Photographs have been included for those who prefer them.

1. Mark post hole positions
2. Install post
3. Install deck
4. Install deck clamp
5. Install pipe clamp
6. Install panel (slide guard/arch wall/etc.) to pipe clamp
7. Leveling Suggestion
8. Leveling Suggestion

1



3



2



4



5



7



6



8



Maintenance Checklist

LOCATION _____ INSPECTOR _____
 DATE _____

INSTRUCTIONS: All playground components are listed below. Check monthly. Train personnel (through study of CPSC Guidelines and ASTM standards) to be alert to playground hazards and report them promptly. Avoid use of hazardous equipment until repaired. Check in equipment column means satisfactory. Letter (R) means needs repair and could be hazardous. Copy this page and explain "R" ratings on reverse side.

Equipment	36" deck	Transfer station	Crawl tunnel	Alpha panel	Guard wall with wheel	Triple rail slide	Slide guard	Deck clamps	Post clamps	Large handhold	Small handhold		
Resilient Surfacing Depth													
Broken glass, trash, foreign objects, etc.													
Exposed or loose concrete footings, other trip hazards													
Missing or broken parts													
Sharp or jagged edges													
Protrusions													
Entanglement, such as open S- hooks													
Rust, rot, cracks, splinters													
S- hooks, hangers, chain. Replace when 25% worn													
Loose or missing hardware													
Drainage, particularly in heavy use areas													
Adequate use zone													
Other (specify)													
Labels legible													