



## **MEGA SERIES INSTALLATION APPENDIX**

# **INSTALLATION APPENDIX**





## MEGA SERIES INSTALLATION APPENDIX

Loose fill surfacing material must be maintained at the required depth within the use zone. Loose fill material must be replaced or added as necessary to maintain its resilient properties.

### **FINAL INSTALLATION STEPS**

\_\_1. Once the entire playground has been assembled level and square each post, deck and component.

\_\_2. Tighten all hardware.

\_\_3. Starting at the center of the structure and working out towards the perimeter of the structure, pour concrete into footing holes. Leave 2” from the top of the hole to the top of the concrete to allow for backfill. Slope concrete down and away from post to water from seeping between the post and the concrete. Refer to the footing sections in the individual component instructions for a cutaway drawing.

\_\_4. Clean off any concrete that may have splashed onto equipment before it dries.

\_\_5. After the concrete has set for a minimum of 48 hours (refer to manufacturers instructions for proper cure time) you should backfill the holes. Also, remove any concrete that is not in the holes so they don’t become a hazard for children.

\_\_6. Install labels as instructed on the next page.

\_\_7. Install Surfacing. A protective surfacing material is required under and around all play equipment within the use zone. If using loose fill surfacing, we recommend a depth of 12” for the entire use zone.



## MEGA SERIES INSTALLATION APPENDIX

### LABEL INSTALLATION

SportsPlay Equipment Inc. has included multiple labels that must be installed on the playground structure as recommended by ASTM.

There are four different labels that, as the owner you are required to install and maintain. If a label becomes damaged please contact your distributor for replacement.

- 1) Warning label – Qty 4
- 2) Supervision and Age Appropriateness – Qty 4
- 3) Manufacturers Identification – Qty 4
- 4) Safety Surfacing – Qty 1 label per post

**\_\_1. Identify the proper location.** The image to the right shows the proper placement for the labels on the playground post. With the exception of the surfacing labels all labels must be placed between 48” and 60” from the top of the surfacing on the main posts in a conspicuous location, on all four sides of the playground that will be visible to adults.

The surfacing labels shall be placed so that the arrows on the label are level with the top of the recommended surfacing.

**\_\_2. Apply.** Once you have identified the proper location for the labels ensure that the location is clean and dry, remove the backing from the label and attach them to the post. Smooth out any wrinkles or bubbles by rubbing the backing piece on the surface of the label.

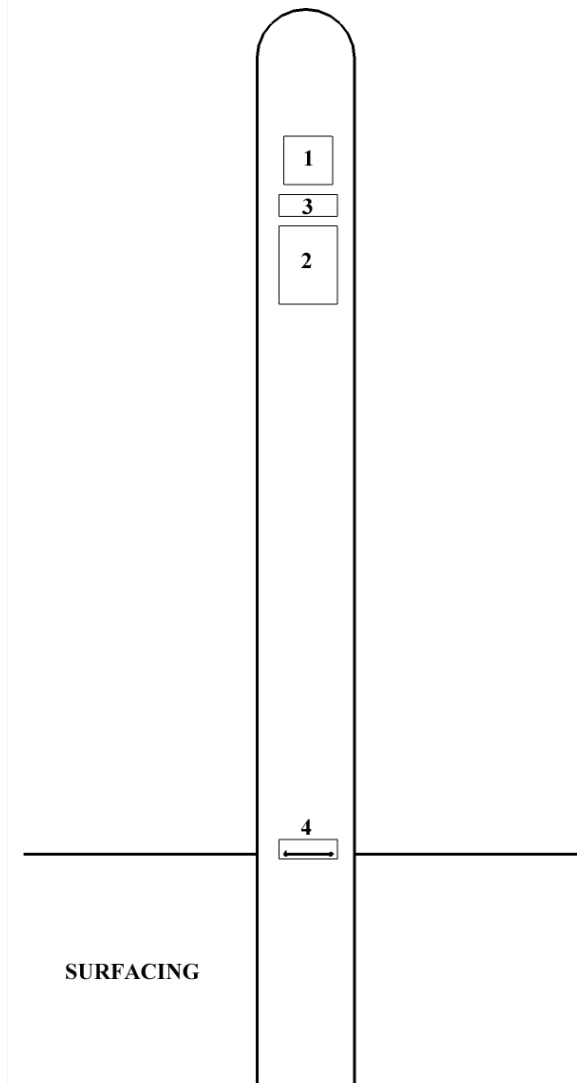



### MAINTENANCE AND INSPECTION PROCEDURES

An inspection and maintenance program is a requirement for all playground equipment. As the owner/operator you are responsible for developing a comprehensive inspection and maintenance program for each piece of equipment you own.

Daily inspections of all play areas and equipment for potential hazards is recommended. Pay special attention to moving parts and other components that are expected to wear. Also inspect for foreign debris (broken glass, nails, sharp metal) that could cause injury in and around all play areas.

At a minimum inspections should be scheduled and performed based on the component maintenance requirements. Inspection is not enough, you must perform necessary maintenance when a problem is identified and the equipment must be taken out of service until it is corrected.

A person familiar with the equipment should perform inspections and maintenance.

The component maintenance sheets and a general inspection checklist are included in the next section of this booklet and as the owner it is your responsibility to ensure that you have a copy of each sheet for each component on your playground. If you require additional maintenance sheets simply contact your distributor for a new copy.

All documents that have been included are originals and you will need to make copies to use while performing the inspections and any required maintenance.

All completed forms should be put on file or you may want to insert them at the end of this manual.

Before making copies, note the site location and identify which playground each form is for, on the form itself to prevent using the forms from this playground on equipment from another playground.

### **SURFACING**

Surfacing should be inspected regularly (daily) to ensure that the required surfacing has not been displaced. Displaced surfacing should be raked back into its proper place to maintain the required depth.

Things to look for during inspection:

1. Heavy traffic areas (swings and slide exits) which are prone to surfacing displacement
2. Standing water: Surfacing compacts much faster when wet.
3. Most loose fill surfacing will no longer function as a protective surfacing when frozen.

**SportsPlay Equipment does not manufacture surfacing and is only providing this information on surfacing as a guide for safety. Please contact the manufacturer of your surfacing for a complete guide on surfacing inspection and maintenance**



## MEGA SERIES INSTALLATION APPENDIX

### UNDERSTANDING THE MAINTENANCE FORMS

The first form is the General Inspection checklist. This form will cover the basic inspection of the play equipment and area. SportsPlay recommends performing this inspection daily as it covers basic safety of the equipment and area. Documenting this inspection is up to you but you can simply laminate a copy and mark each item with a dry erase marker before allowing access to the area.

After the general maintenance checklist you will find the component maintenance forms. There are two types of components maintenance forms. The first type covers common components or items found on all playgrounds SportsPlay Equipment manufactures (ex: main posts, labels, four hole brackets, footings etc...). The other type of component maintenance forms is specific to the components found on your playground (specific slide, climber, etc...).

Each component form has two sections. The first gives details about what to look for and how to make repairs (not all problems can be repaired in the field) and the second part is the form you will use while performing the inspection/maintenance. The second part includes the inspection checklist and recommended frequency along with a spot to document the date, pass or fail and a signature line for the inspector. If repairs were required there is a spot to list the problem and the action taken. Once these forms have been completed you should either insert them into the back of this manual or keep them on file elsewhere.

Remember that the documents furnished are the originals and copies should be made to use for the actual inspection.



## **ORIGINAL INSPECTION AND MAINTENANCE FORMS**







## MEGA SERIES INSTALLATION APPENDIX

### GENERAL INSPECTION CHECKLIST

#### **Adequate surfacing under and around equipment**

- Surfacing material is in good condition
- Ensure surfacing materials are not compacted (rake and fluff if necessary)
- Inspect and remove all foreign objects from play area
- No sharp edges on equipment
- No missing pieces of equipment
- No protruding bolts
- No potential clothing entrapments
- All safety guards are in place
- No open crush or shearing points on moving parts
- Inspect and remove or fix all trip hazards (rocks or exposed footings)

- No loose or missing hardware
- Moving parts (example: swings) are not worn
- Swing chains are not looped over the top bar of the swing set
- There are no modifications to the playground
- No strings or rope tied to the equipment
- No liter, tree branches or other debris in and around the play area
- No obvious damage to the play equipment
- Equipment is securely installed
- Windows and bubbles are securely installed with no sign of wear
- Equipment appears to be installed level and square (no obvious tilt or lean)

### Inspect all posts for the following:

- Verify that all hardware is in place and secure
  - Bolts & Nuts – Snug tight and then tighten an additional  $\frac{1}{4}$  turn
  - Set Screws – Snug tight and then tighten an additional full turn
  - Should you discover hardware is broken or missing order replacement parts immediately Refer to the component installation instructions for part identification
- You will perform this inspection when performing your component inspections

### Replacement Parts

- Contact your distributor to order new labels. If unable to contact distributor please call SportsPlay Equipment for replacements: 1-314-389-4140
- Before calling be sure to identify the proper part, part number and quantity needed
- When ordering replacement hardware you need to order replacement tools since most hardware is tamper resistant

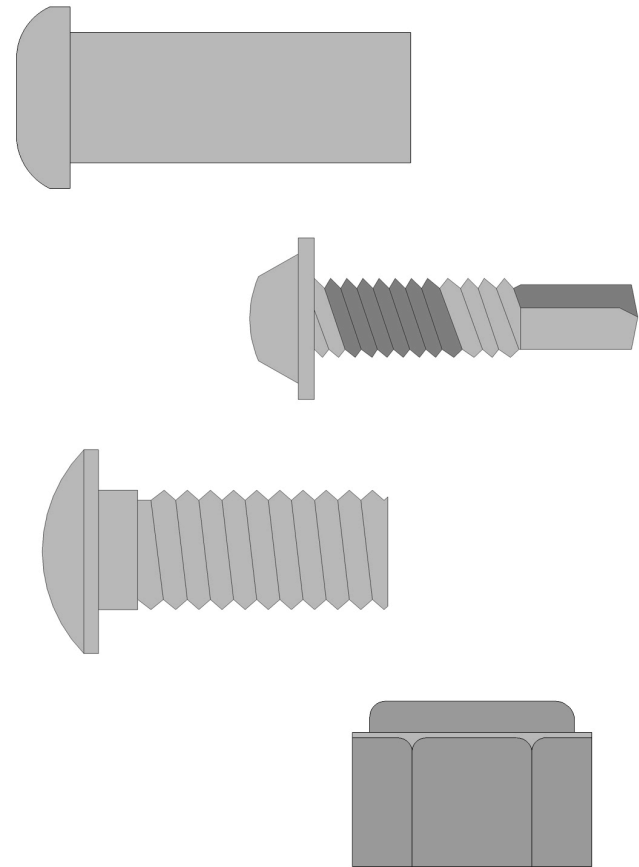

### Footings

- Move surfacing (if loose fill) to expose the footing
- Inspect concrete for cracks or loose supports
  - If cracked footings or loose supports are found you must excavate the soil around the concrete, remove the concrete and pour a new footing
- Replace or move the surfacing back into position and verify correct surfacing levels are maintained in and around the play equipment

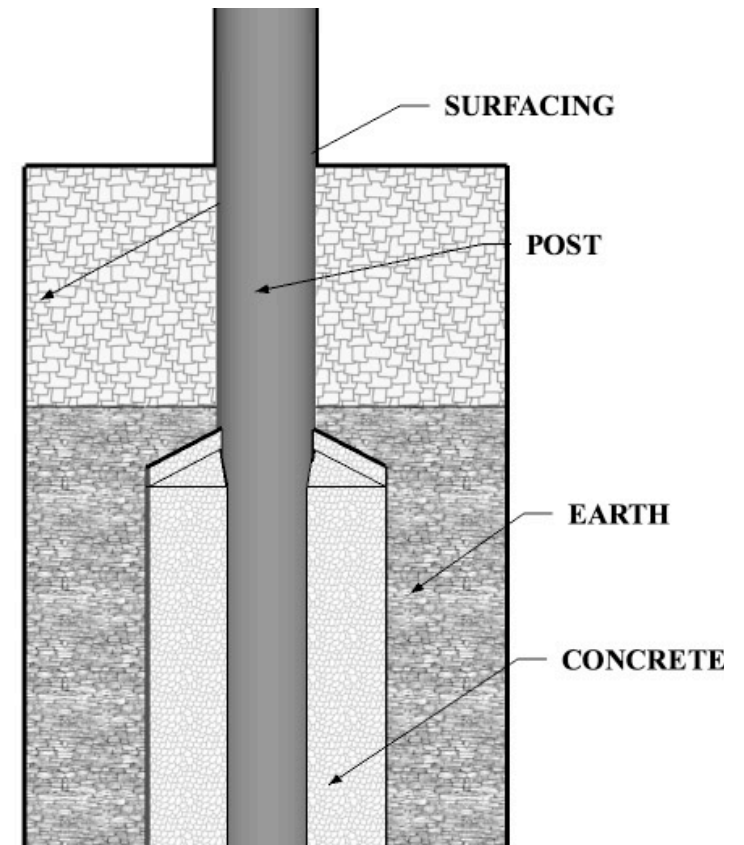



**INSPECTION FORM**

- MAKE COPIES OF THIS FORM TO USE FOR INSPECTION
- REVIEW THE “MAINTENANCE GUIDE” IN THE APPENDIX TO BETTER UNDERSTAND THE IMPORTANCE OF MAINTENANCE AND HOW TO DEVELOP A MAINTENANCE SCHEDULE.
- DOCUMENT ALL MAINTENANCE ACTIONS ON THE LIST AS WELL AS ANY NOT LISTED.
- INCLUDE DATES AND SIGNATURES

Inspection Checklist	Recommended Frequency	Grade (Pass/Fail/NA)	Date Inspected	Date Repairs Completed
Inspect footings for cracks	Yearly			
Inspect footings for loose supports	Yearly			

Inspector: \_\_\_\_\_ Signature: \_\_\_\_\_ Date: \_\_\_\_\_

<b>Maintenance Record</b>			
Part	Problem	Corrective Action	Date

**Inspect all four labels at all locations for the following:**

- The labels are present
- The labels are not worn
- There are Manufactures id, age group and warning labels (labels 1-3 on the drawing to the right) on all four sides at eye level.
- Each post shall have a surfacing level label (label 4 on the drawing) at the proper position on the post
- If any of the labels are worn or missing order replacements

**Installing new labels**

- Clean the surface where the label is being applied
- Allow surface to dry
- Apply label
- Use the label backing material to smooth out all wrinkles and bubbles

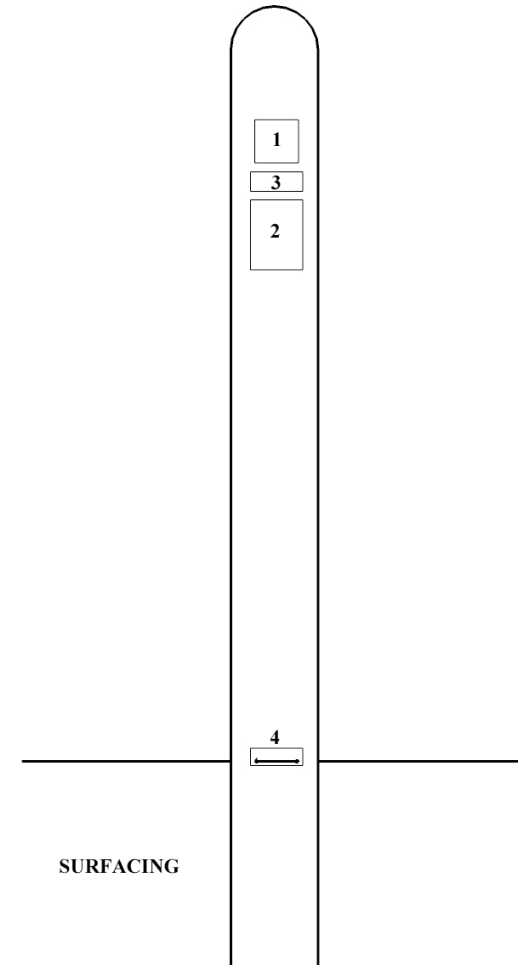

**Replacement Parts**

- Contact your distributor to order new labels. If unable to contact distributor please call SportsPlay Equipment for replacements: 1-314-389-4140



**INSPECTION FORM**

- MAKE COPIES OF THIS FORM TO USE FOR INSPECTION
- REVIEW THE “MAINTENANCE GUIDE” IN THE APPENDIX TO BETTER UNDERSTAND THE IMPORTANCE OF MAINTENANCE AND HOW TO DEVELOP A MAINTENANCE SCHEDULE.
- DOCUMENT ALL MAINTENANCE ACTIONS ON THE LIST AS WELL AS ANY NOT LISTED.
- INCLUDE DATES AND SIGNATURES

Inspection Checklist	Recommended Frequency	Grade (Pass/Fail/NA)	Date Inspected	Date Repairs Completed
Inspect Labels	Monthly			

Inspector: \_\_\_\_\_ Signature: \_\_\_\_\_ Date: \_\_\_\_\_

<b>Maintenance Record</b>			
Part	Problem	Corrective Action	Date

**Inspect all posts for the following:**

- Verify all posts are securely installed in the concrete footing
  - Review the footing maintenance document for repair procedure should you discover a post is not secure
- Inspect paint for damage, if damaged:
  - If powder coating needs to be repaired sand surface and mask off area. Coat with primer and once the primer has dried paint with color matching touch up paint. Contact distributor of color matching paint.
- Verify there are no sharp edges
  - If there are sharp edges or gouges smooth them down and touch up the paint using the procedure above

**Replacement Parts**

- Contact your distributor to order new labels. If unable to contact distributor please call SportsPlay Equipment for replacements: 1-314-389-4140

**LABELS**

- Should you discover a damaged label during inspection, review the label maintenance sheet for instructions on how to replace them.

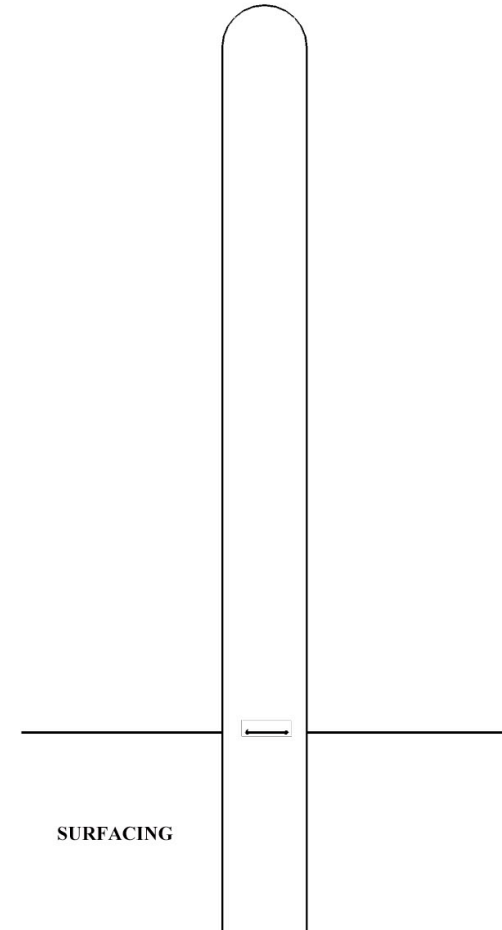



**INSPECTION FORM**

- MAKE COPIES OF THIS FORM TO USE FOR INSPECTION
- REVIEW THE “MAINTENANCE GUIDE” IN THE APPENDIX TO BETTER UNDERSTAND THE IMPORTANCE OF MAINTENANCE AND HOW TO DEVELOP A MAINTENANCE SCHEDULE.
- DOCUMENT ALL MAINTENANCE ACTIONS ON THE LIST AS WELL AS ANY NOT LISTED.
- INCLUDE DATES AND SIGNATURES

Inspection Checklist	Recommended Frequency	Grade (Pass/Fail/NA)	Date Inspected	Date Repairs Completed
Inspect posts for damage	Monthly			
Verify posts are secure in footings	Monthly			

Inspector: \_\_\_\_\_ Signature: \_\_\_\_\_ Date: \_\_\_\_\_

Maintenance Record			
Part	Problem	Corrective Action	Date



### **Deck Attachment**

- Ensure deck is securely attached to post and all hardware is in place and in good condition

### **Hardware**

- Inspect for loose or missing hardware. Tighten all loose hardware and replace all missing hardware. Block off access to equipment if necessary.
- Order new hardware from SportsPlay Equipment Inc.

### **Welds**

- Inspect all welds for cracks. If a crack is found block access to the playground and contact your distributor for replacement parts immediately.

### **Finish**

- Inspect all metal components for coating damage. If powder coating needs to be repaired sand surface and mask off area. Coat with primer and once the primer has dried paint with color matching touch up paint. Contact distributor of color matching paint. Contact Distributor for Thermoplastic repair kit.

**Surfacing** - Refer to the surfacing maintenance sheet.

### **Replacement Parts**

- Reference the parts list on page 2 of the instruction set for this component to identify the part/s correctly.
- Contact your distributor to order parts.

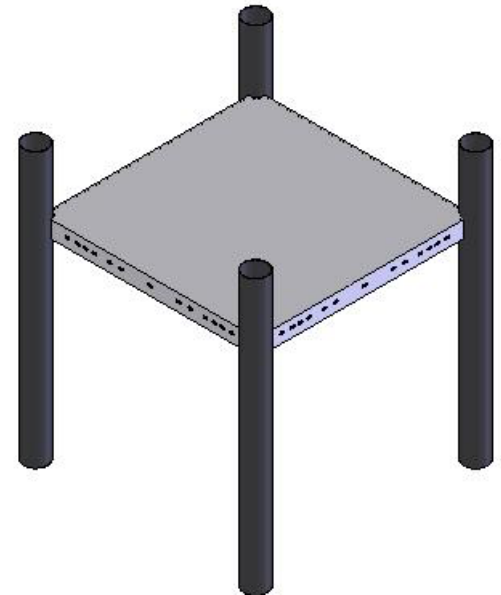



### **Deck Attachment**

- Ensure deck is securely attached to post and all hardware is in place and in good condition

### **Hardware**

- Inspect for loose or missing hardware. Tighten all loose hardware and replace all missing hardware. Block off access to equipment if necessary.
- Order new hardware from SportsPlay Equipment Inc.

### **Welds**

- Inspect all welds for cracks. If a crack is found block access to the playground and contact your distributor for replacement parts immediately.

### **Finish**

- Inspect all metal components for coating damage. If powder coating needs to be repaired sand surface and mask off area. Coat with primer and once the primer has dried paint with color matching touch up paint. Contact distributor of color matching paint. Contact Distributor for Thermoplastic repair kit.

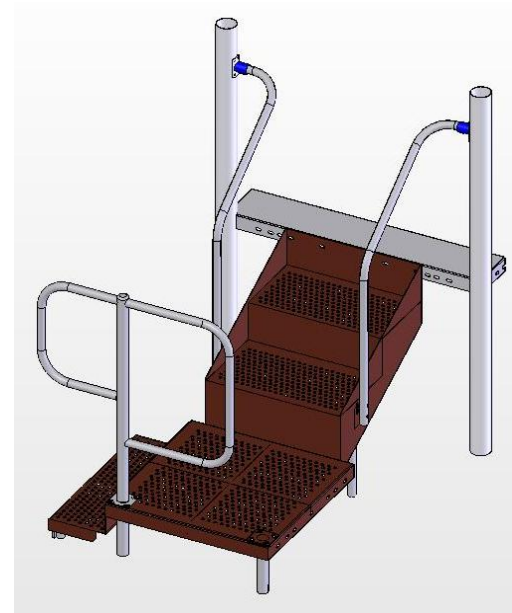

**Surfacing** - Refer to the surfacing maintenance sheet.

### **Replacement Parts**

- Reference the parts list on page 2 of the instruction set for this component to identify the part/s correctly.
- Contact your distributor to order parts.



**INSPECTION FORM**

- MAKE COPIES OF THIS FORM TO USE FOR INSPECTION
- REVIEW THE “MAINTENANCE GUIDE” IN THE APPENDIX TO BETTER UNDERSTAND THE IMPORTANCE OF MAINTENANCE AND HOW TO DEVELOP A MAINTENANCE SCHEDULE.
- DOCUMENT ALL MAINTENANCE ACTIONS ON THE LIST AS WELL AS ANY NOT LISTED.
- INCLUDE DATES AND SIGNATURES

Inspection Checklist	Recommended Frequency	Grade (Pass/Fail/NA)	Date Inspected	Date Repairs Completed
Inspect Deck Attachment to Post	Monthly			
Inspect Hardware	Monthly			
Inspect Finish	Monthly			

Inspector: \_\_\_\_\_ Signature: \_\_\_\_\_ Date: \_\_\_\_\_

Maintenance Record			
Part	Problem	Corrective Action	Date

### **Brackets**

- Inspect all four-hole clamps and panel clamps.
- Ensure the setscrews are tight and in place.
- Ensure all Torx Screws are in place and that the bracket is firmly attached to post.
- Inspect the clamps for cracks and sharp edges. Smooth any sharp edges and fix the finish. Replace brackets if cracked.

### **Hardware**

- Inspect for loose or missing hardware. Tighten all loose hardware and replace all missing hardware. Block off access to equipment if necessary.

### **Welds**

- Inspect all welds for cracks. If a crack is found block access to the playground and contact your distributor for replacement parts immediately.

### **Finish**

- Inspect all metal components for coating damage. If powder coating needs to be repaired sand surface and mask off area. Coat with primer and once the primer has dried paint with color matching touch up paint. Contact distributor of color matching paint. Contact Distributor for Thermoplastic repair kit.

**Surfacing** - Refer to the surfacing maintenance sheet.

### **Footings**

- Inspect all footings to ensure equipment is secure. You must block access to prevent access until repair is made.

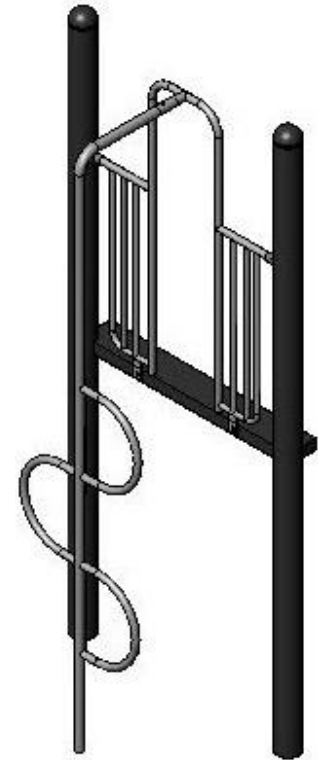

### **Replacement Parts**

- Reference the parts list on page 2 of the instruction set for this component to identify the part/s correctly.
- Contact your distributor to order parts.



### **Brackets**

- Inspect all four-hole clamps and panel clamps.
- Ensure the setscrews are tight and in place.
- Ensure all Torx Screws are in place and that the bracket is firmly attached to post.
- Inspect the clamps for cracks and sharp edges. Smooth any sharp edges and fix the finish. Replace brackets if cracked.

### **Hardware**

- Inspect for loose or missing hardware. Tighten all loose hardware and replace all missing hardware. Block off access to equipment if necessary.

### **Plastic Components**

- Inspect for any sharp edges or deformities. Minor deformities and sharp edges can be repaired using a utility knife. Block off access until repairs are made. Contact distributor for replacement parts.

### **Welds**

- Inspect all welds for cracks. If a crack is found block access to the playground and contact your distributor for replacement parts immediately.

### **Finish**

- Inspect all metal components for coating damage. If powder coating needs to be repaired sand surface and mask off area. Coat with primer and once the primer has dried paint with color matching touch up paint. Contact distributor of color matching paint. Contact Distributor for Thermoplastic repair kit.

**Surfacing** - Refer to the surfacing maintenance sheet.

### **Slide**

- Refer to “Plastic Components” section.
- Inspect run-out section of the slide for standing water. Adjust the slide by digging up existing footing and install it slightly lower to increase the slope of the slide.

### **Footings**

- Inspect all footings to ensure equipment is secure. You must block access to prevent access until repair is made.

### **Replacement Parts**

- Reference the parts list on page 2 of the instruction set for this component to identify the part/s correctly.
- Contact your distributor to order parts.

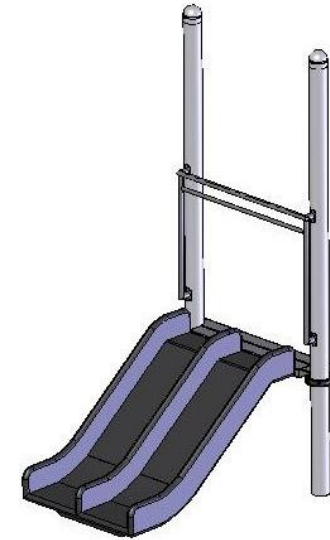





### **Brackets**

- Inspect all four-hole clamps and panel clamps.
- Ensure the setscrews are tight and in place.
- Ensure all Torx Screws are in place and that the bracket is firmly attached to post.
- Inspect the clamps for cracks and sharp edges. Smooth any sharp edges and fix the finish. Replace brackets if cracked.

### **Hardware**

- Inspect for loose or missing hardware. Tighten all loose hardware and replace all missing hardware. Block off access to equipment if necessary.

### **Plastic Components**

- Inspect for any sharp edges or deformities. Minor deformities and sharp edges can be repaired using a utility knife. Block off access until repairs are made. Contact distributor for replacement parts.

### **Welds**

- Inspect all welds for cracks. If a crack is found block access to the playground and contact your distributor for replacement parts immediately.

### **Finish**

- Inspect all metal components for coating damage. If powder coating needs to be repaired sand surface and mask off area. Coat with primer and once the primer has dried paint with color matching touch up paint. Contact distributor of color matching paint. Contact Distributor for Thermoplastic repair kit.

**Surfacing** - Refer to the surfacing maintenance sheet.

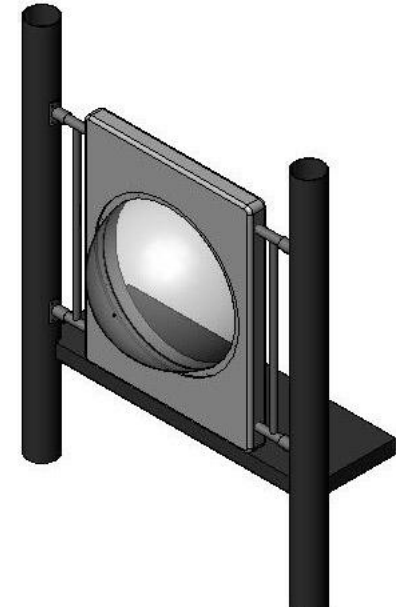

### **Footings**

- Inspect all footings to ensure equipment is secure. You must block access to prevent access until repair is made.

### **Replacement Parts**

- Reference the parts list on page 2 of the instruction set for this component to identify the part/s correctly.
- Contact your distributor to order parts.



### **Brackets**

- Inspect all four-hole clamps and panel clamps.
- Ensure the setscrews are tight and in place.
- Ensure all Torx Screws are in place and that the bracket is firmly attached to post.
- Inspect the clamps for cracks and sharp edges. Smooth any sharp edges and fix the finish. Replace brackets if cracked.

### **Hardware**

- Inspect for loose or missing hardware. Tighten all loose hardware and replace all missing hardware. Block off access to equipment if necessary.

### **Plastic Components**

- Inspect for any sharp edges or deformities. Minor deformities and sharp edges can be repaired using a utility knife. Block off access until repairs are made. Contact distributor for replacement parts.

### **Welds**

- Inspect all welds for cracks. If a crack is found block access to the playground and contact your distributor for replacement parts immediately.

### **Finish**

- Inspect all metal components for coating damage. If powder coating needs to be repaired sand surface and mask off area. Coat with primer and once the primer has dried paint with color matching touch up paint. Contact distributor of color matching paint. Contact Distributor for Thermoplastic repair kit.

**Surfacing** - Refer to the surfacing maintenance sheet.

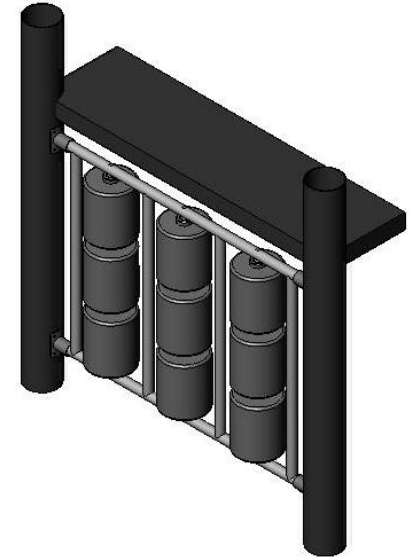

### **Footings**

- Inspect all footings to ensure equipment is secure. You must block access to prevent access until repair is made.

### **Replacement Parts**

- Reference the parts list on page 2 of the instruction set for this component to identify the part/s correctly.
- Contact your distributor to order parts.



### **Brackets**

- Inspect all four-hole clamps and panel clamps.
- Ensure the setscrews are tight and in place.
- Ensure all Torx Screws are in place and that the bracket is firmly attached to post.
- Inspect the clamps for cracks and sharp edges. Smooth any sharp edges and fix the finish. Replace brackets if cracked.

### **Hardware**

- Inspect for loose or missing hardware. Tighten all loose hardware and replace all missing hardware. Block off access to equipment if necessary.

### **Plastic Components**

- Inspect for any sharp edges or deformities. Minor deformities and sharp edges can be repaired using a utility knife. Block off access until repairs are made. Contact distributor for replacement parts.

### **Welds**

- Inspect all welds for cracks. If a crack is found block access to the playground and contact your distributor for replacement parts immediately.

### **Finish**

- Inspect all metal components for coating damage. If powder coating needs to be repaired sand surface and mask off area. Coat with primer and once the primer has dried paint with color matching touch up paint. Contact distributor of color matching paint. Contact Distributor for Thermoplastic repair kit.

**Surfacing** - Refer to the surfacing maintenance sheet.

### **Slide**

- Refer to “Plastic Components” section.
- Inspect run-out section of the slide for standing water. Adjust the slide by digging up existing footing and install it slightly lower to increase the slope of the slide.

### **Footings**

- Inspect all footings to ensure equipment is secure. You must block access to prevent access until repair is made.

### **Replacement Parts**

- Reference the parts list on page 2 of the instruction set for this component to identify the part/s correctly.
- Contact your distributor to order parts.

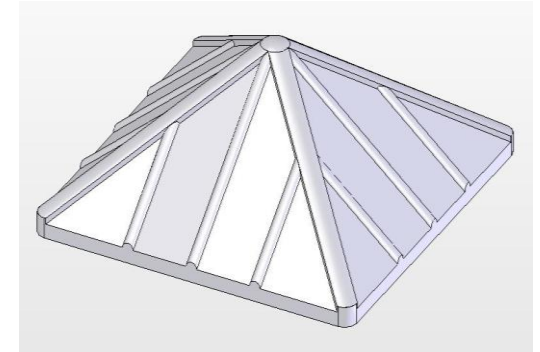





## **MEGA SERIES INSTALLATION APPENDIX**

### **COMPLETED INSPECTION AND MAINTENANCE FORMS**