

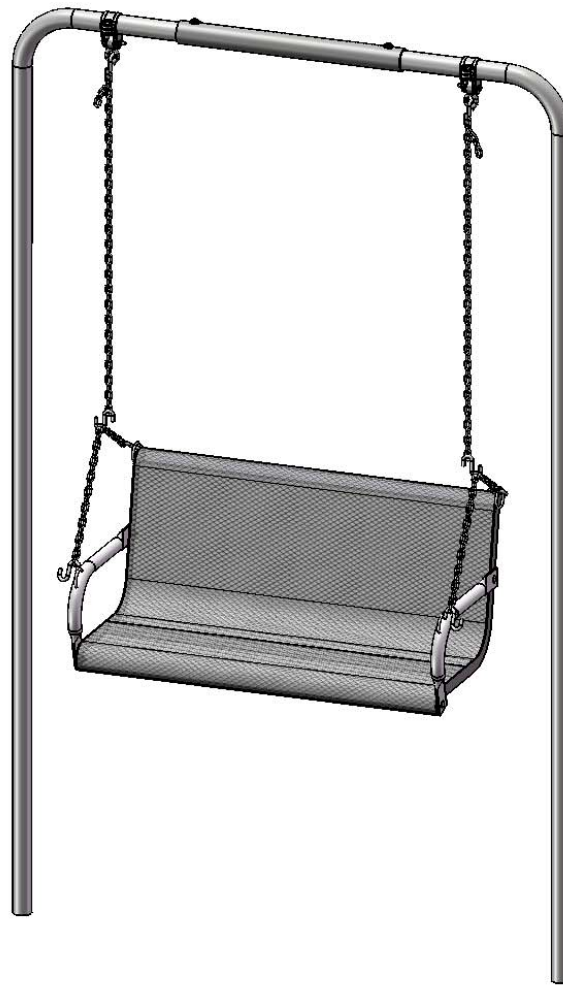

A PLAYCORE Company



Model #967-V4



A PLAYCORE Company

1675 Locust Street
Red Bud, IL 62278
Phone: 618-282-8200
Fax: 618-282-8202

WARRANTY & TERMS

WARRANTY: 5 Year Limited Warranty on Thermoplastic coated elements. Ultra Play guarantees all items for one full year to be free of defects in workmanship or materials when installed and maintained properly. We agree to repair or replace, any items determined to be defective. Items specifically not covered by this warranty include vandalism, man made or natural disasters, lack of maintenance, normal weathering or wear and tear due to public abuse.

Damages or loss in transit is the responsibility of the carrier, whether visible or concealed. It is the responsibility of the recipient to assure that the order is received complete. Before signing the delivery receipt, inspect the shipment immediately and completely. Note any damages or shortages on the bill of lading. Damage reports must be filed within 10 days. Ultra Play is NOT responsible for damages or loss in transit. Title to all goods passes to the customer at the time of shipment. Ultra Play will assist in filing claims if the freight arrangements were made by Ultra Play at your request.

CANCELLATIONS AND RETURNS: Cancellations are only accepted with approval of Ultra Play. No merchandise shall be returned without a Return Goods Authorization number which is issued by customer service. Any authorized merchandise must be carefully packed and received in saleable condition. A restocking charge of up to 25% will be applied to all returned goods when the error is not the fault of Ultra Play. All returns must be shipped freight prepaid.



A PLAYCORE Company

SAFETY WARNINGS & EQUIPMENT INSPECTION

- Owners and installers please note these safety warnings and make use of this checklist on a regular basis.
- Follow installation instructions when erecting equipment.
- Ground surfaces around equipment should be restored as needed. Concrete footings should never be exposed. Surface depth should comply with ASTM and CPSC specifications.
- Check for and repair damage caused by wear or vandalism, a major factor in injury causing situations.
- All protruding bolts should be covered or cut off and finished smooth. Sharp edges on pipes should be capped or removed. Check for bent, broken, or severely worn pipe, and replace.
- All equipment should be free of rust and repainted whenever necessary to deter rusting.
- We provide our customers with layout sheets and installation instructions. Please keep on file the specifications sheet that contains the listing of every part used.
- Never add components not intended for use with this product.
- Regular maintenance is necessary in this and all park and recreational equipment to insure the safety of the user.
- Note: Proper maintenance of equipment requires regular tightening of all bolts, nuts, and setscrews.
- Note: Regular checking of all parts, castings, etc. should be made. If a part is broken or worn, it should be replaced immediately.
- Check to be sure all fittings are tight and that bars and pipes do not move.
- Replace all worn S-hooks. S-hooks must be completely closed. Failure to close S-hooks can result in serious injury to the user. NEVER reuse S-hooks.
- Test for free movement of swing hanger and other moving attached parts.
- Check for worn chains and replace them.
- A soft resilient surface should be placed under all swings extending at least twice the height of the top rail both front and back.

HARDWARE



1/2" x 3/4"
Set Screw

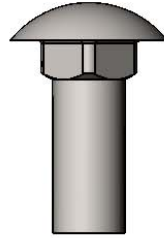

3/8" x 1"
Carriage Bolt

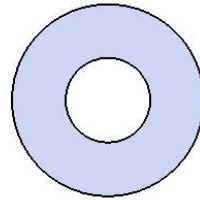

3/8" Flat Washer

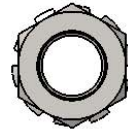

3/8" Kep Nut

TOOLS REQUIRED

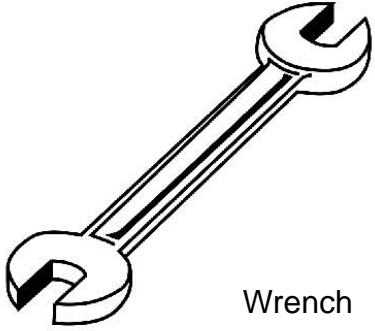

Wrench

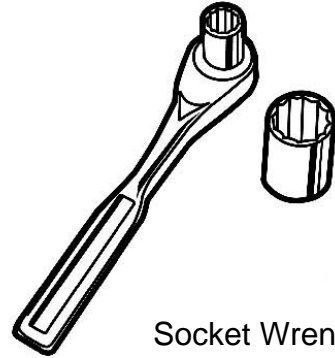

Socket Wrench

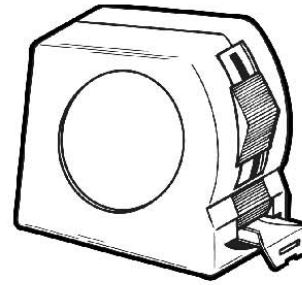

Tape Measure

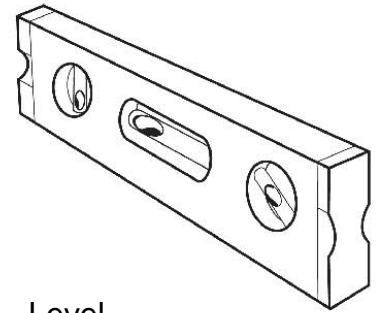

Level

USE ZONE

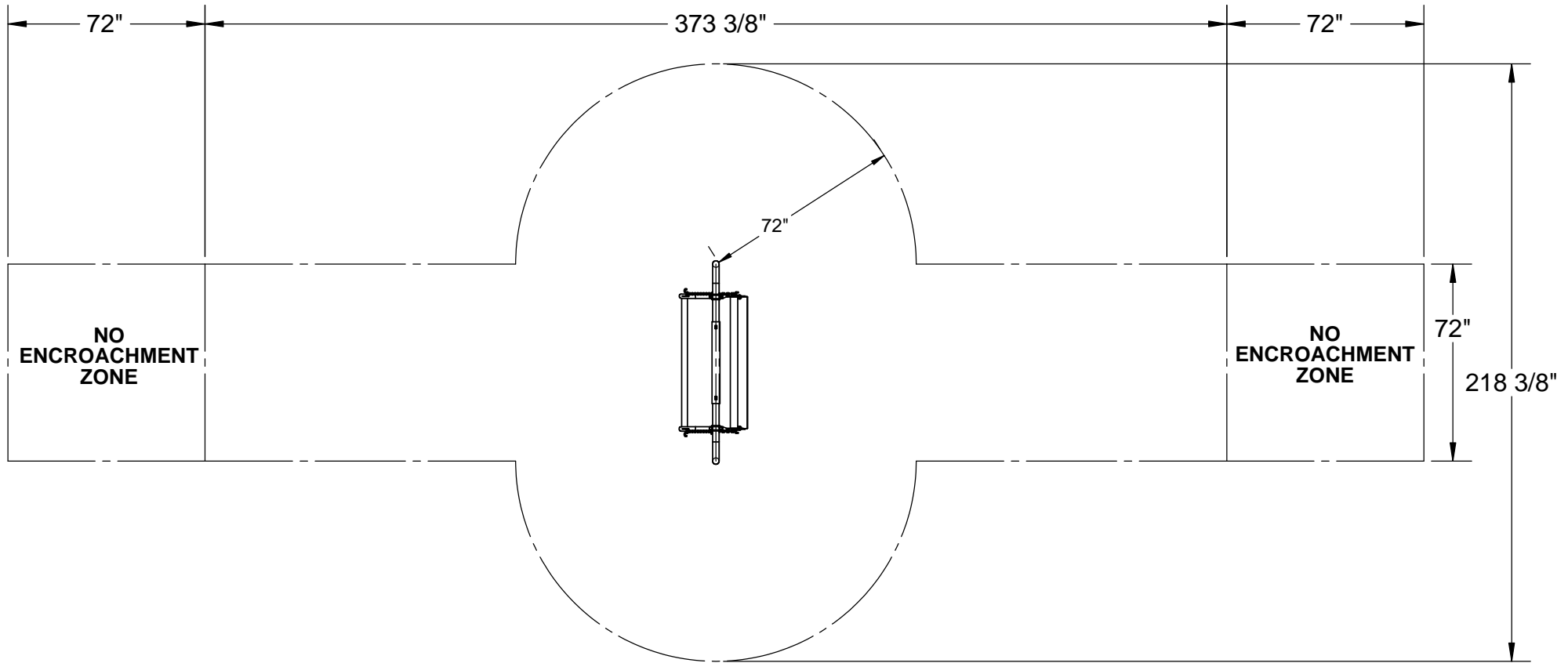

MINIMUM USE ZONE REQUIRED.

ULTRA SITE PRODUCT SPECIFICATIONS

967-V4 CONTOURED BENCH SWING WITH BACK, INGROUND

Seats: Seats dimensions are 24-3/4" x 15-1/8". 3/4" #9 steel expanded metal. End plates are made of 7 gauge flat steel plate. Reinforced with 3/16 x 1-1/2" flat strip. Electrically MIG welded.

Seat Coating: Oven fused functionalized polyethylene copolymer-based thermoplastic. Fluidized bed coating application with superior mechanical performance, impact resistance and UV-stability.

Frame: Legs are 2-3/8" O.D. x 10 gauge pre-galvanized structural steel tubing. Seat support is bent over a mandrel through the bend radius producing a wrinkle free bend. All electrically MIG welded. Galvanized Bearing hangers shall be malleable with oil impregnated bushings. Bench shall be suspended by a 4' chain.

Frame Coating: Electrostatic powder coated application oven cured.

Hardware: All stainless steel hardware fasteners.

Dimensions: 4' bench with back. Seats are 24-3/4" wide x 15-1/8" high. Seat height is 18" from the ground to the top of the seat.

Critical Fall Height: Fall height is 92-3/4" from the pivot point of the swing to the ground.

COMPONENTS

ITEM NO.	PartNo	DESCRIPTION	QTY.
1	V967-48	967 4' Leg	2
2	01-01-0183	967 Sleeve	1
3	55-SH-09	Swing Hanger For 2-38" OD	2
4	55-H155	S Hook	8
5	02-07-0205	49" Swing Chain	2
6	01-01-0190	967 11" Short Swing Chain	2
7	01-01-0191	967 19" Long Swing Chain	2
8	T-V48CT-967	4' Expanded Contour Seat	1
9	01-01-0185	967 Armrest - Welded	2
10	33-05-0009	1/2" x 3/4" set screw SS	2
11	33-06-0042	3/8" x 1" Carriage Bolt (SS)	4
12	33-02-0008	3/8" Flat Washer (SS)	4
13	33-03-0013	3/8" Kep Nut (SS)	4

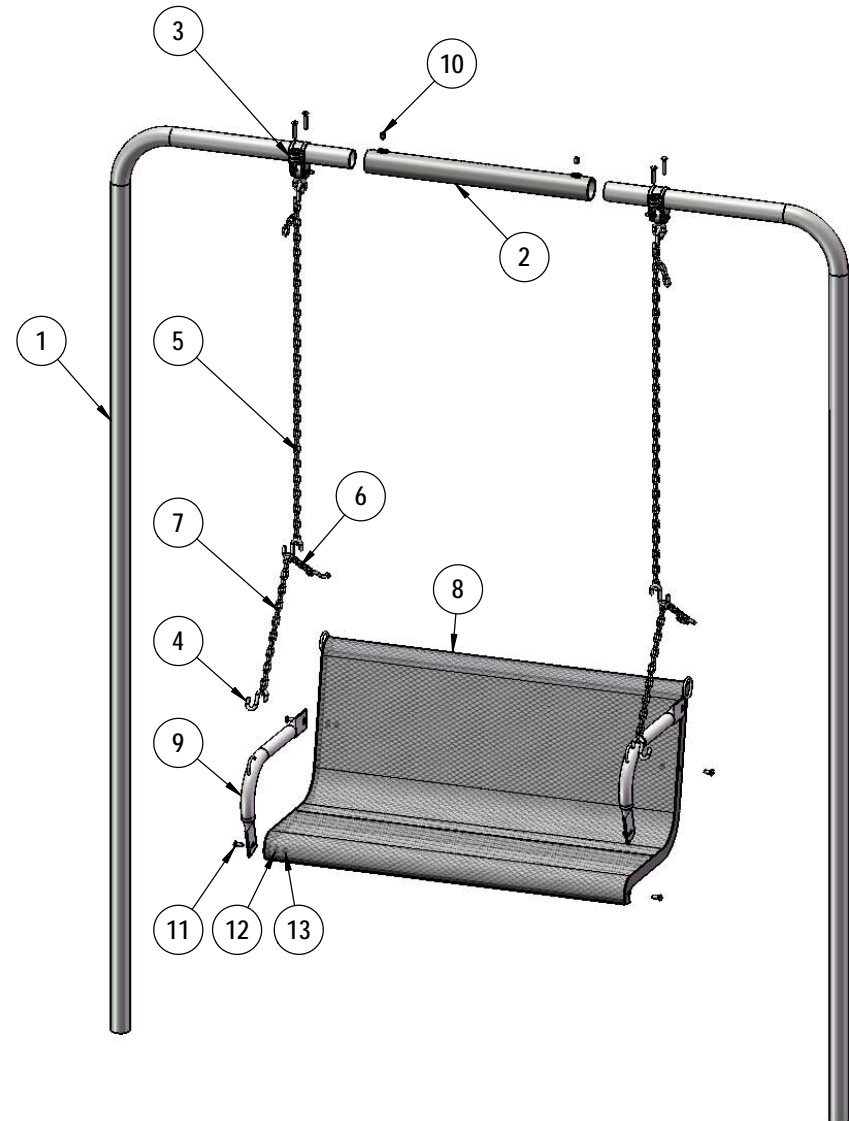

STEP 1

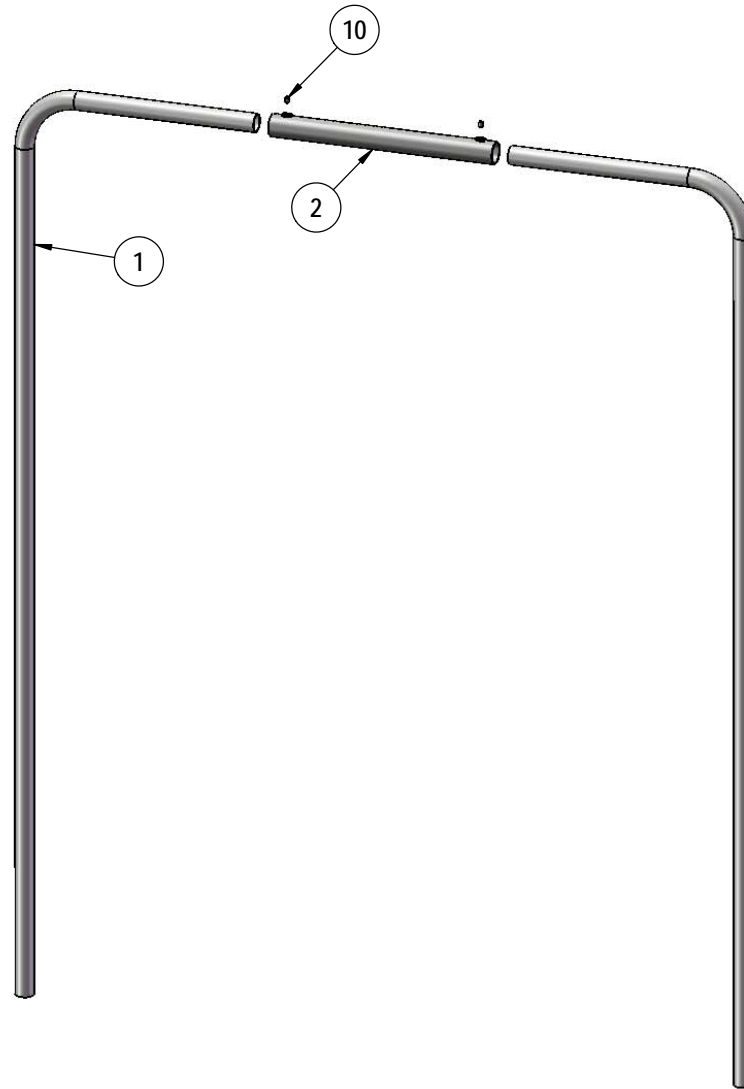

Before Footings are poured attach the 967 Sleeve to the 967 Legs using the specified hardware at the appropriate width. Tighten hardware till it is tight against the 967 leg.

FOOTINGS

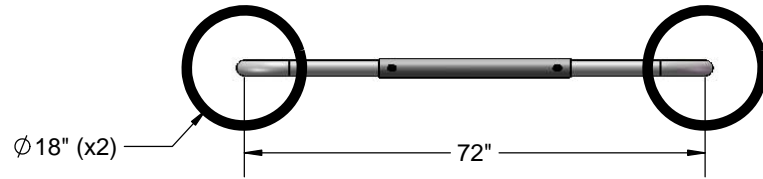

Estimated Required Concrete: 22 - 50lb. bags of Concrete

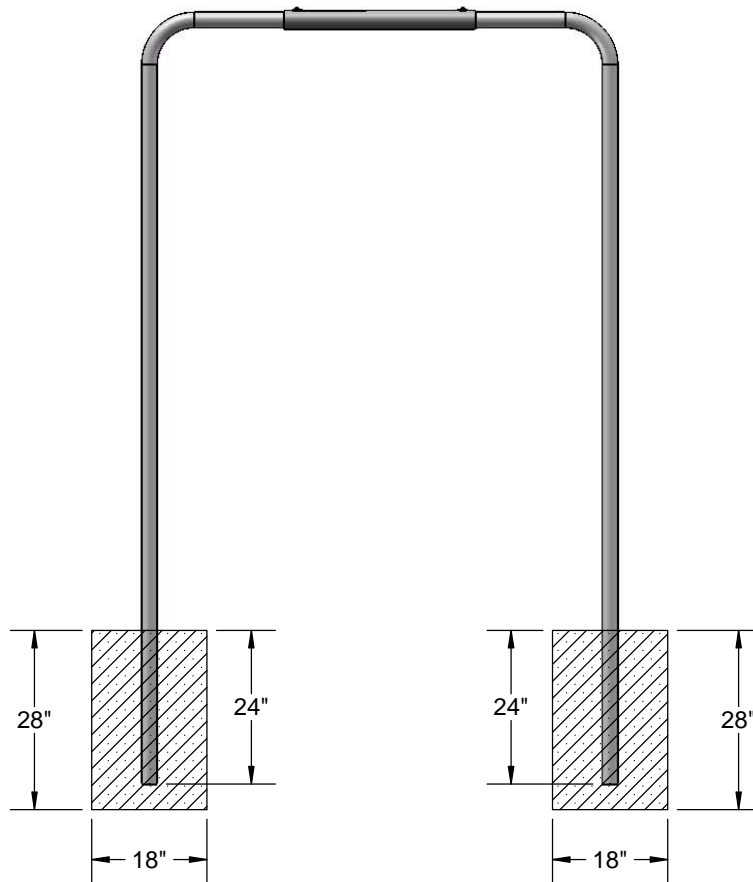

After Step 1 place 967 Legs into footings and pour the estimated amount of Concrete to fill footings. While curing continue to Step 2.

STEP 2

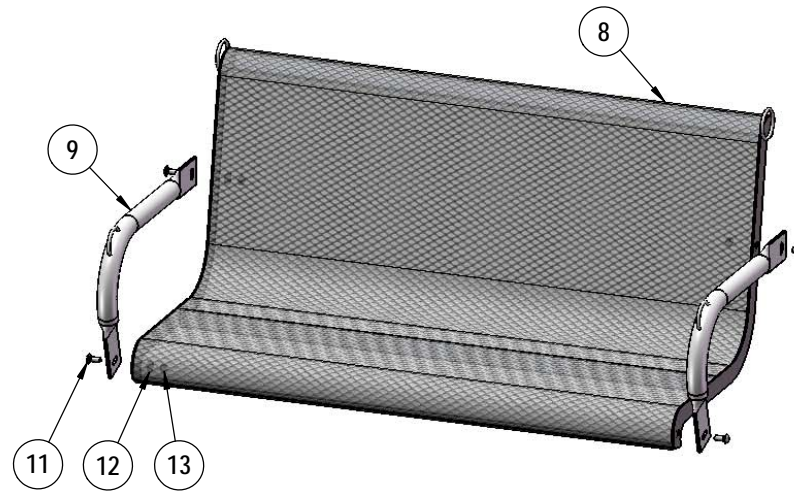

While waiting for Footings to cure attach the 967 Armrest to the 967 Bench using the specified hardware.

STEP 3

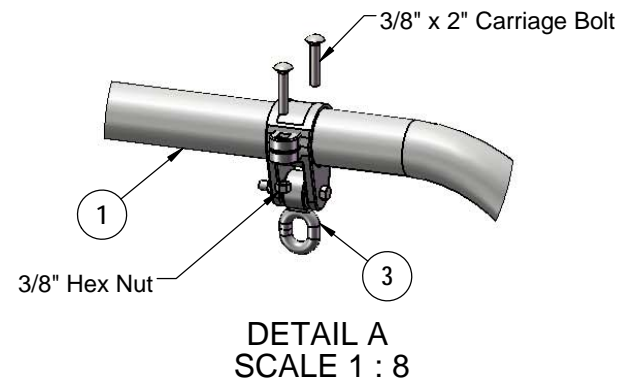
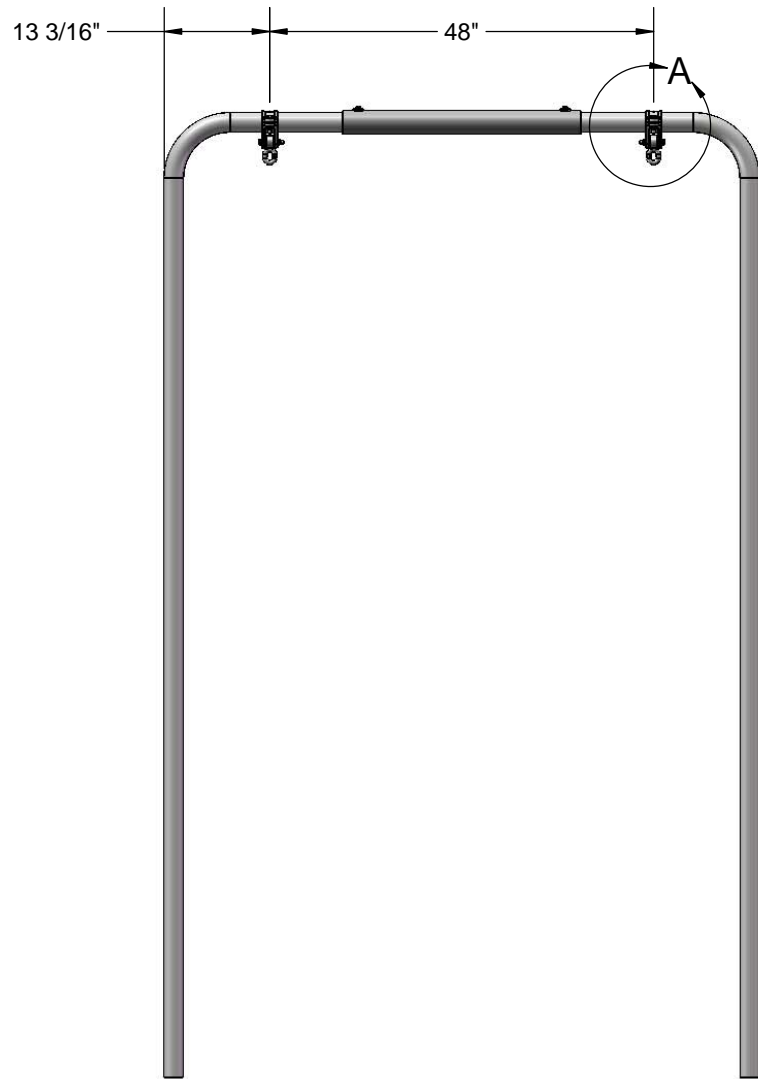

After Footings have cured attach the 2- Swing Hangers to the 967 Legs using the specified hardware. At the appropriate distance apart from each other.

STEP 4

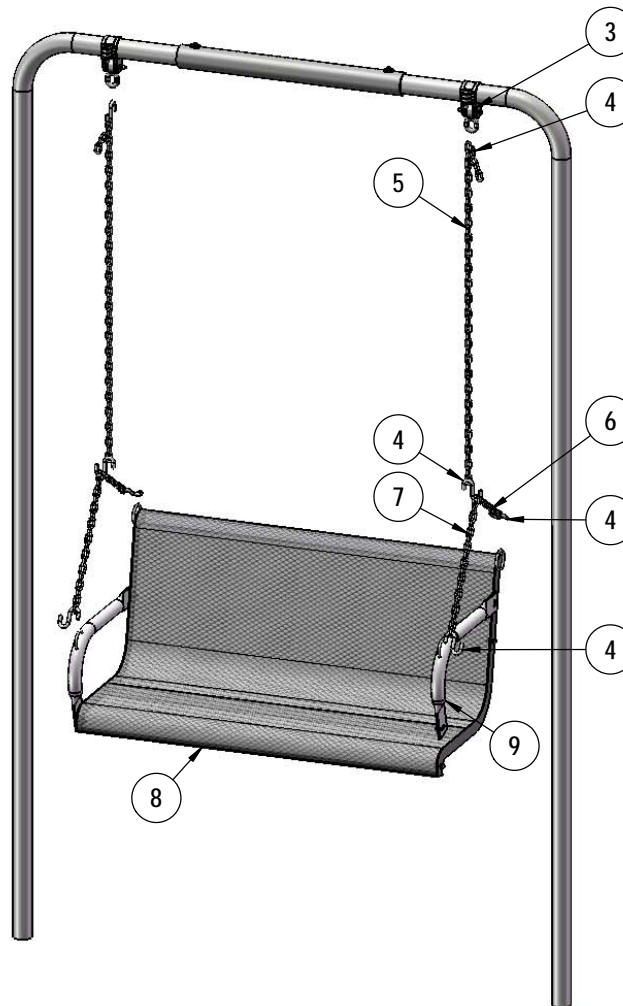

Attach the 967 11" and 19" Swing Chains to the 967 Bench using the S Hooks. S Hooks must hook through the loops on the 967 Bench and 967 Arms. Then attach the 11" Short Swing Chain to the 19" Long Swing Chain together using a S Hook. Next attach the 49" Swing Chain to the now attached S Hook that is attached to the 11" and 19" Swing Chains. Now on the other end of that 49" Swing Chain attach the final S Hooks to the Chain and then to the Swing Hanger at the desired length. We recommend where the top of the seat of the 967 Bench is approximately 18" from Ground Level.

OVERALL DIMENSIONS

