

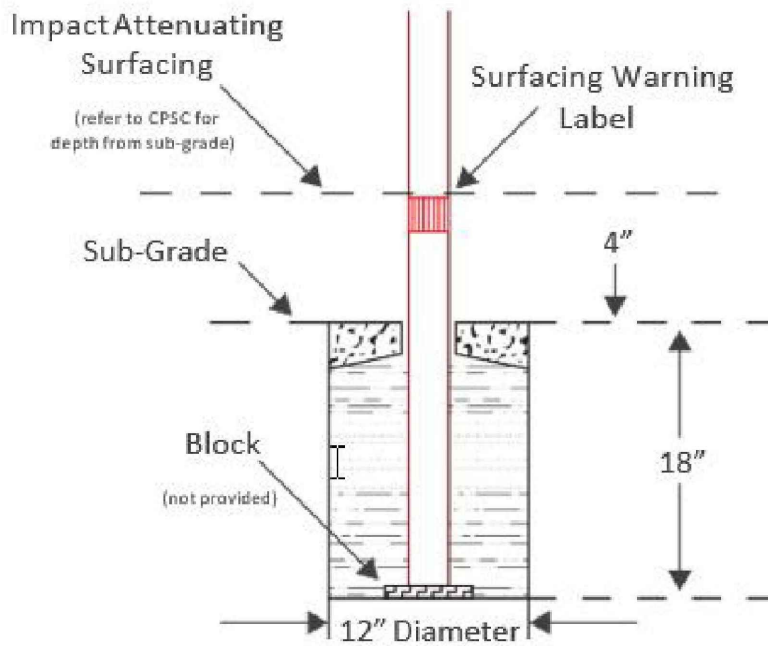

WISDOM PLAYGROUND

CUSTOMER'S GUIDE



Inground Mount Option

Component Support Leg Detail

Support Post Detail

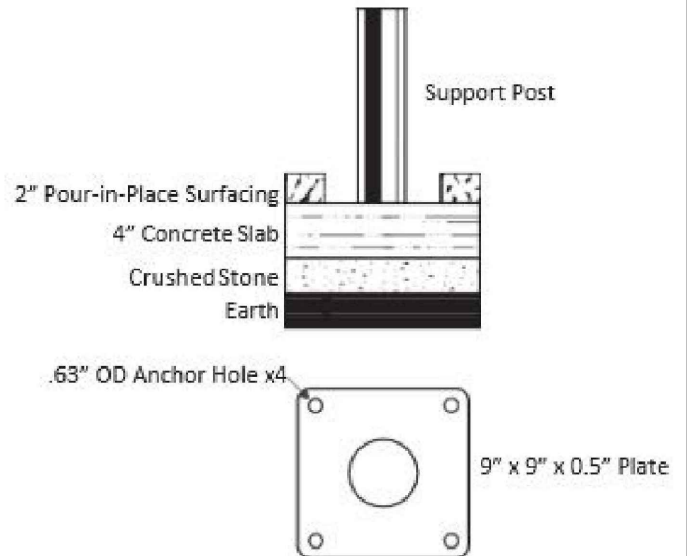
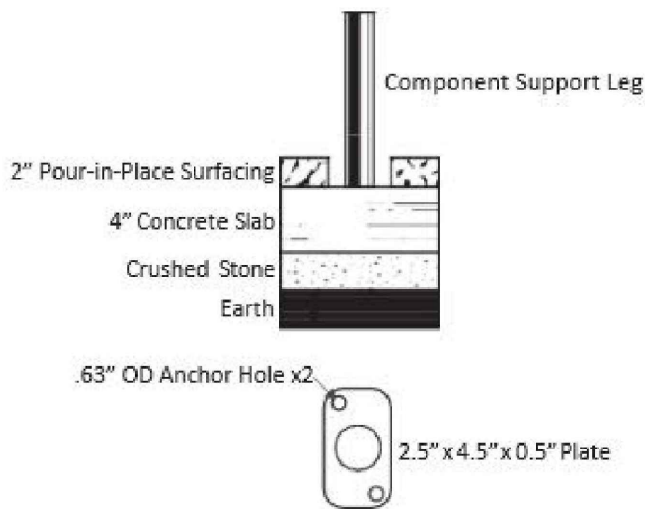

Surface Mount Option

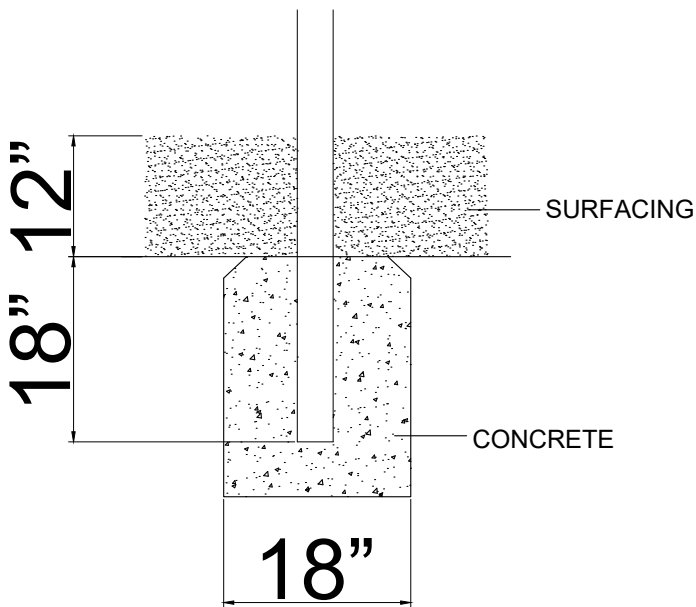
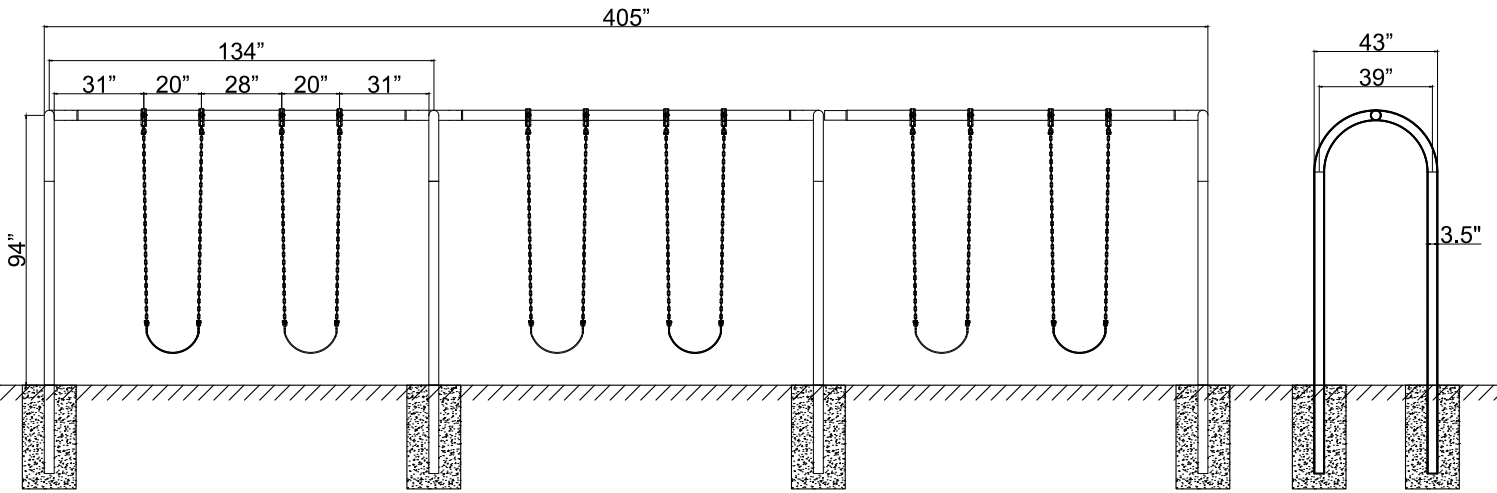

POST IN GROUND MOUNTING

Installation steps:

1:Align the corresponding holes on Arch Swing Frame Beam with Arch Swing Frame End Post

2:Insert corresponding hardware and tighten.

Arch Swing Frame End Post

| Number | Name | Model | Quantity |
|--------|----------------------------|--------------|----------|
| 1 | TAMPER RESISTANT TORX-BOLT | M10*105 | 2 |
| 2 | LOCK NUT | M10 | 2 |
| 3 | PLASTIC CAP | φ34 M10 | 4 |
| 4 | FLAT WASHER | 10.5/25*T1.5 | 4 |
| | | | |

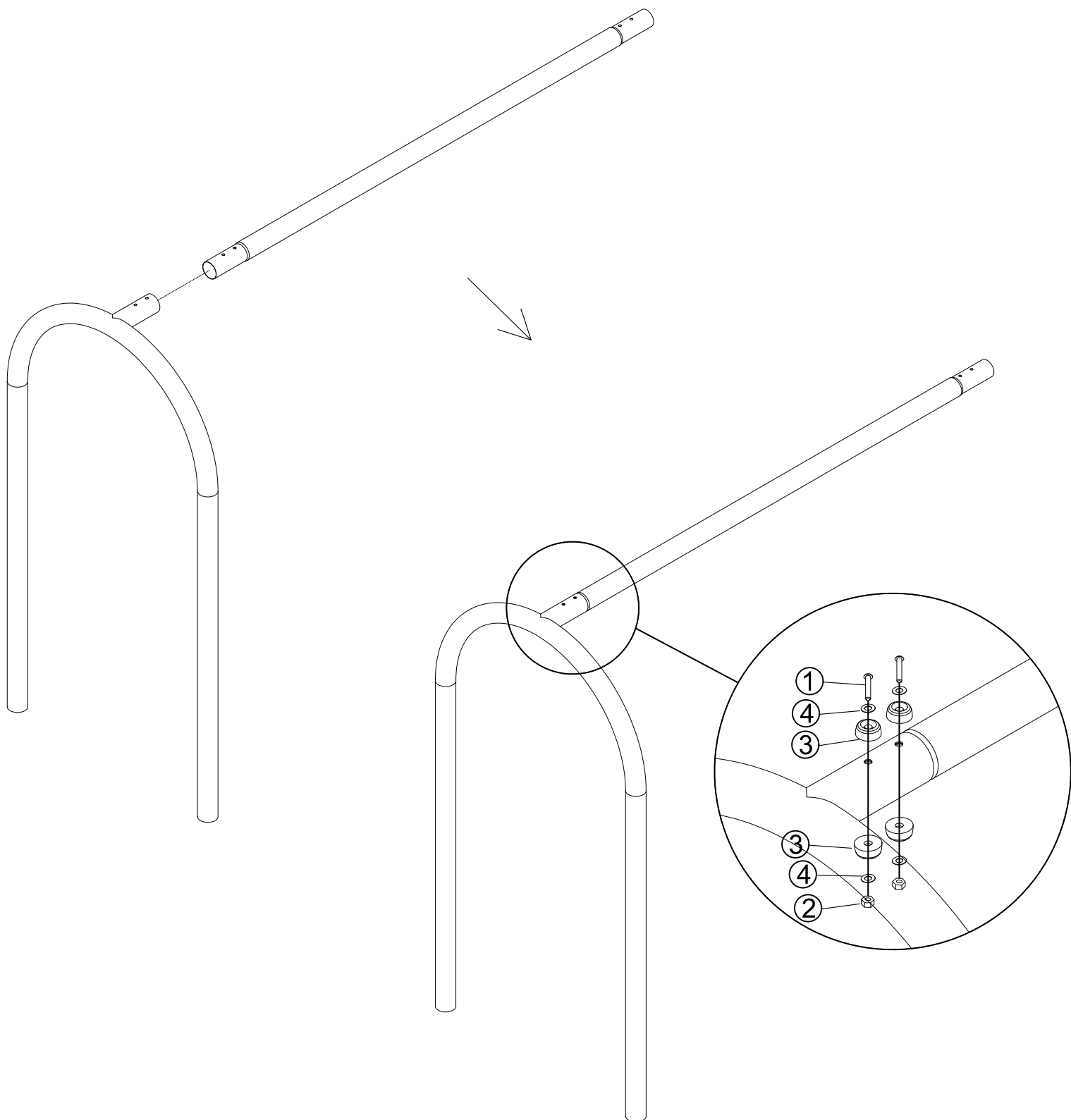

Installation steps:

1:Align the corresponding holes on Arch Swing Frame Beam with Arch Swing Frame Center Post.

2:Insert corresponding hardware and tighten.

Arch Swing Frame Center Post

| Number | Name | Model | Quantity |
|--------|----------------------------|--------------|----------|
| 1 | TAMPER RESISTANT TORX-BOLT | M10*105 | 4 |
| 2 | LOCK NUT | M10 | 4 |
| 3 | PLASTIC CAP | φ34 M10 | 8 |
| 4 | FLAT WASHER | 10.5/25*T1.5 | 8 |
| | | | |

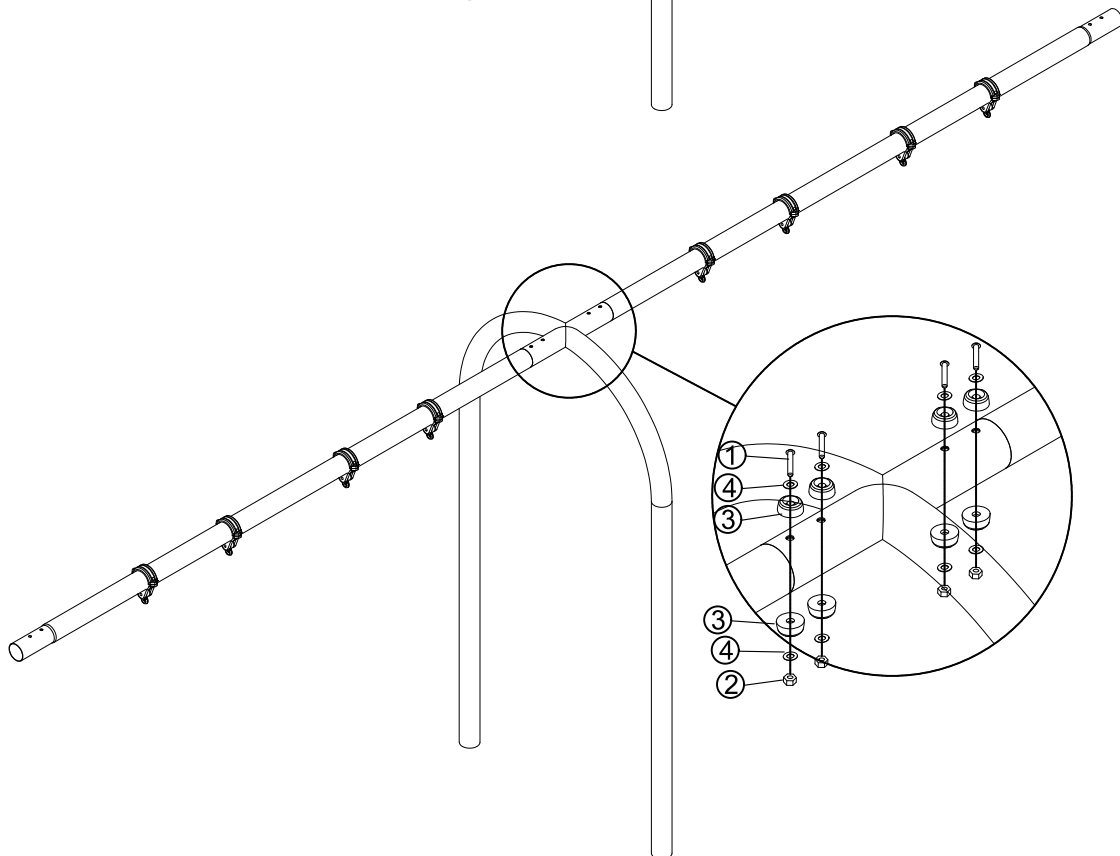
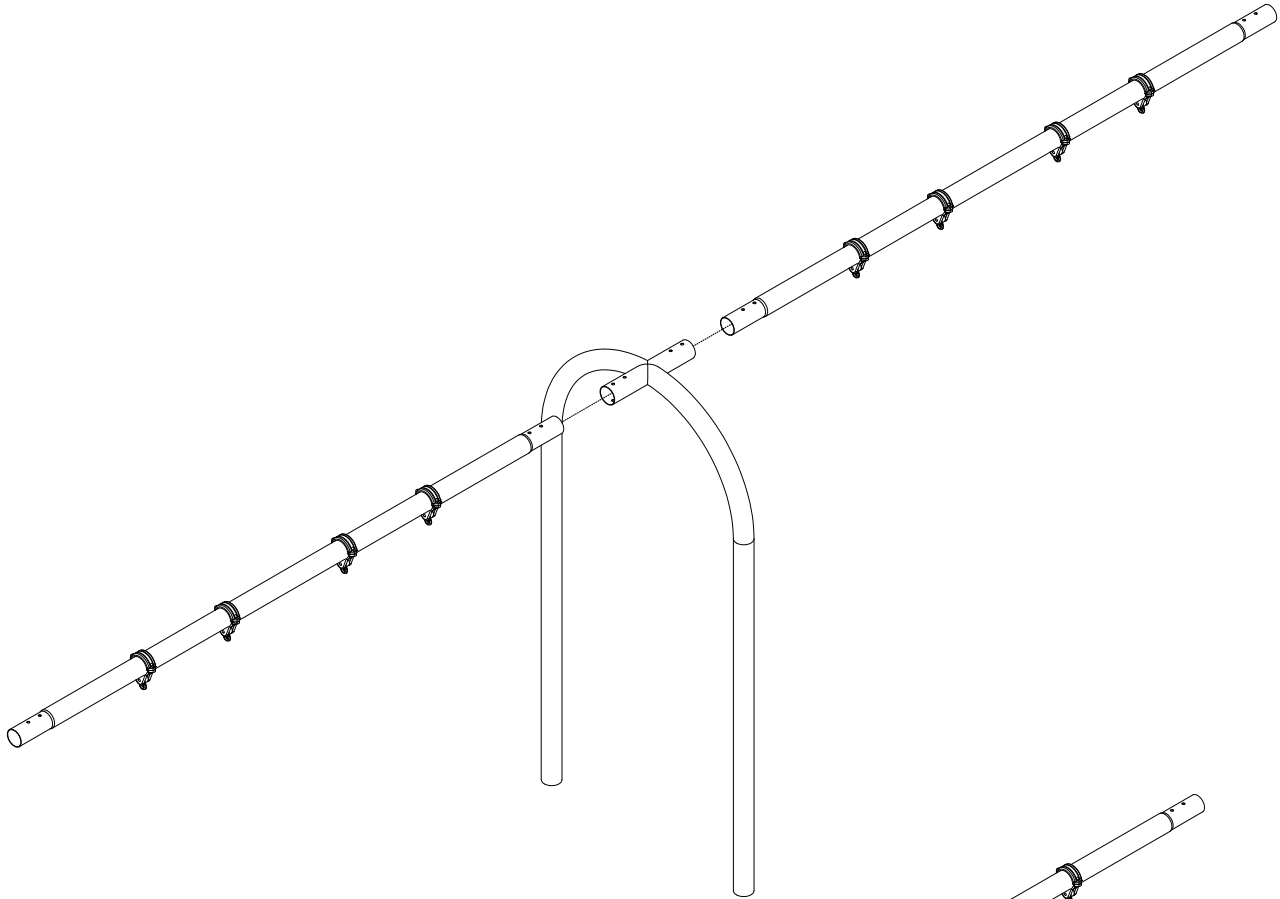

Installation steps:

1: Use 2 x Single Clevis Connector to connect Swing Clamp with Galvanized Chain, as shown on the overhead drawing.

2: Use 1 x Single Clevis Connector to connect Swing Seat with Galvanized Chain, as shown on the overhead drawing.

Full Bucket Seat

| Number | Name | Model | Quantity |
|--------|------|-------|----------|
| | | | |
| | | | |
| | | | |
| | | | |
| | | | |

