

Place the primary bearing assembly over the end of the support post.

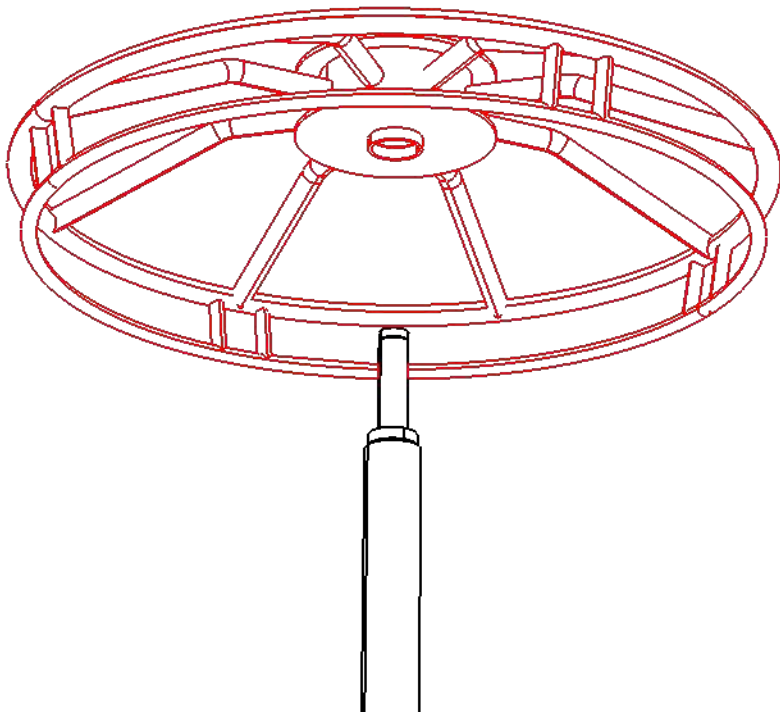

Set the main rotating section onto the support post and primary bearing assembly

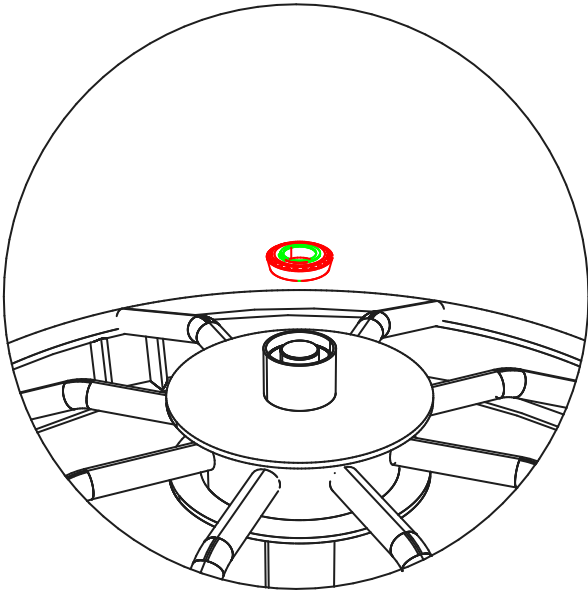

Place the secondary bearing assembly into the slot on top of the support post, then using the provided pliers set the lock ring over the support post and into the locking groove.

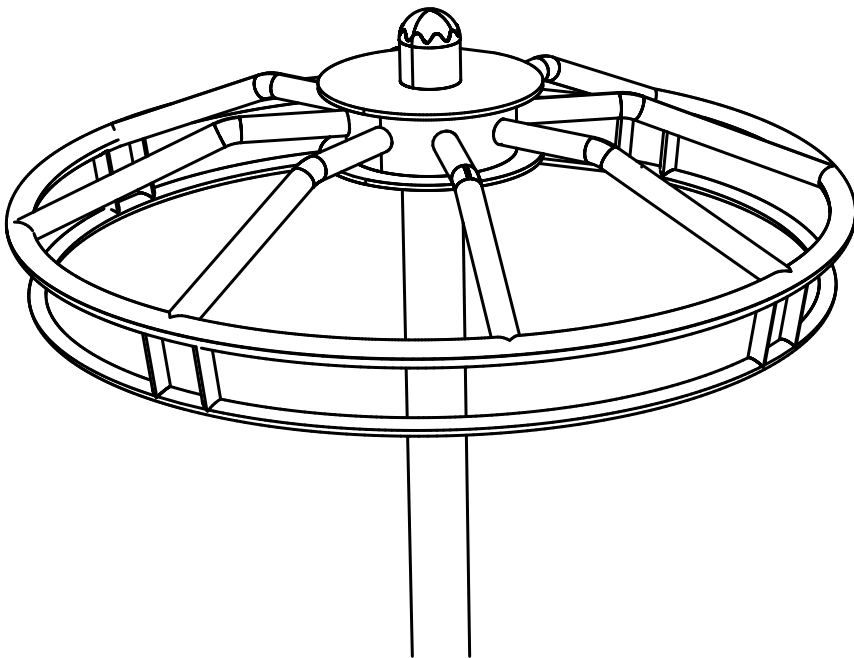

Set the post cap into place on top of the support post, ensuring that it snaps into place.