

Panel Assembly Mounting:

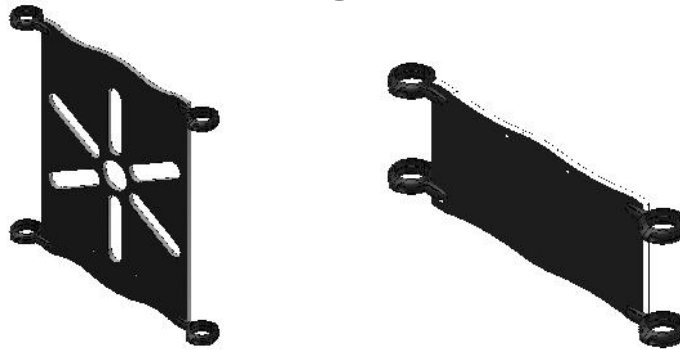

NOTE:

This assembly is not a stand alone structure, and must be connected to solidly build structure.

Please refer to guidelines as specified by the CPSC and ASTM F1487

-) Please review assembly and component **Diagrams**.
-) Verify **component & hardware** quantities received.
-) Familiarize yourself with the **installation procedures**.

1) **Parts Inventory and Set-Up**



Confirm that all components, hardware and special tools are included (see *Parts List*). Gather any additional tools necessary for installation. Please follow diagrams and instructions in order.

2) **Assembly- General**

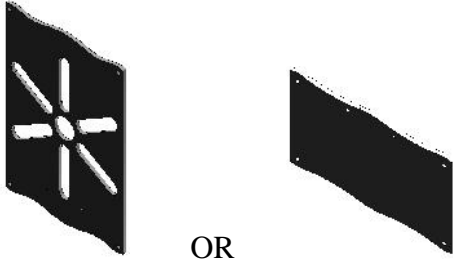

Please use correct type and length fasteners included in the hardware kit for this assembly. Be sure to follow the assembly order to ease the construction procedure. Start all screws before tightening them.

PARTS LIST

Assembly Components:

Item	Qty.	Description	Drawing	Part Number
A	(1)	Panel		180-##### OR 181-#####
B	(4)	3.5" Panel Bolt Clamp		935-127-0003

Hardware Components: (0-3.5INPNLHWKIT)

<u>Item</u>	<u>Qty.</u>	<u>Description</u>	<u>Drawing</u>	<u>Part Number</u>
HA	(4)	5/16-18 x 1-1/2 SS Torx Bolt		100-516112
HB	(4)	Flat Washer 1"x.4"x.07"		100-815FWSS
HC	(4)	5/16-18 Nylock Nut		100-516NLN

Tools: (SUPPLIED IN INSTALLERS HW KIT)

<u>Item</u>	<u>Qty.</u>	<u>Description</u>	<u>Drawing</u>	<u>Part Number</u>
TA	(1)	Torx Driver Bit - T40		100-00T40

Installation procedure:

- 1) Loosely mount the clamps to the poles that the panel is designated to mount to.

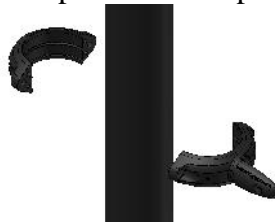

- 2) Bolt Clamp to panel face using (4) 5/16-18 x 1-1/2 SS Torx Bolt (HA), (4) Flat Washer 1"x.4"x.07" (HB), and (4) 5/16-18 Nylock Nut (HC).

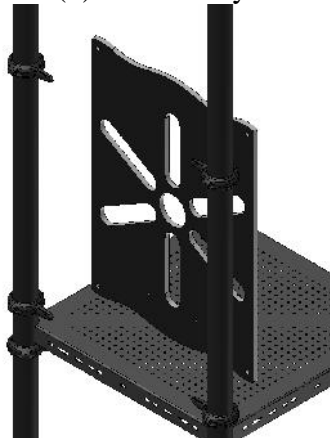

- 3) Level and adjust all clamps as needed and then tighten around poles and tighten to panel.

Panel Table Assembly Mounting:

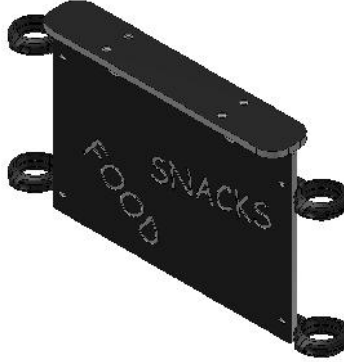

180-13000

After following the steps from above by mounting the panel base to the poles move to next step.







PARTS LIST

Assembly Components:

<u>Item</u>	<u>Qty.</u>	<u>Description</u>	<u>Drawing</u>	<u>Part Number</u>
C	(1)	Base Panel		180-13001
D	(4)	Table Top		180-13002

Hardware Components: (0-3.5PNLTBLHWKIT)

<u>Item</u>	<u>Qty.</u>	<u>Description</u>	<u>Drawing</u>	<u>Part Number</u>
HD	(4)	5/16-18 x 3/4 SS Torx Head Bolt		100-51634
HE	(2)	5/16-18 x 1 SS Torx Head Bolt		100-5161
HF	(6)	5/16-18 T-Nut SS		100-516TNS
HG	(4)	SS L-Bracket		100-LBRKTSS

Tools: (SUPPLIED IN INSTALLERS HW KIT)

<u>Item</u>	<u>Qty.</u>	<u>Description</u>	<u>Drawing</u>	<u>Part Number</u>
-------------	-------------	--------------------	----------------	--------------------

TA	(1)	Tee Nut Wrench		100-TNUTW
----	-----	----------------	--	-----------

Installation procedure:

- 1) Take the Shelf (D) and attach loosely (4) L-Brackets (HG) to the bottom of the shelf with longer end attaching to shelf using (1) 5/16-18 x 3/4 Torx Head Bolt (HD) and (1) 5/16-18 T-Nut SS (HF) per bracket. (As Shown)

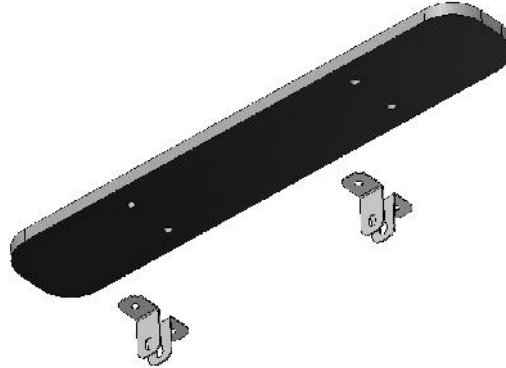

- 2) Slide the shelf onto the base sandwiching the base between the L-brackets. Attach the shelf using (2) 5/16-18 x 1 Torx Head Bolt (HE) and (2) 5/16-18 T-Nut SS (HF). (As Shown)



- 3) Follow Steps 1-3 from panel assembly above to mount to poles.

REV	ECO	DATE	BY	APRV
A		11-09-2012	DAH	