



Fitness Equipment General Installation

PLEASE NOTE THE FOLLOWING:

STORAGE:

When equipment is received at a job site it should be installed as soon as possible (within a few days from receipt). The equipment is packaged to keep it safe and damage-free during shipment. However, the packaging material is not suited for periods of extended storage in an uncontrolled environment. The combination of moisture from the environment mixed with the heat generated inside the plastic wrapping may cause damage to the finish of the powder-coated items.

If an immediate installation is not possible, certain steps should be taken to minimize the risk of damage to the equipment. If play equipment must be stored, ideally it should be kept in a controlled environment (storage container, inside building, etc...) away from heat and moisture. If this is not possible, the packaging material should be removed from the equipment, using caution so as not to damage the finish with special regard given to powder coated items.

INVENTORY:

Please note that inventory should only be taken with the Packing List that ships with each job.

FOOTING INFORMATION:

The following footing guidelines are general and do not supersede any specific information given in any individual set of drawings or instructions. Footing detail drawings are given at the end of this document. Recommended concrete minimum: 2500 PSI.

18" Wide x 18" Deep Footing (does not include safety surfacing depth)

Used for Primary Support Posts for In-Ground mounted equipment, or when surface mounting using J-Bolts (J-Bolts not provided.)

12" Wide x 12" Deep Footing (does not include safety surfacing depth)

Used for Secondary Supports for In-Ground mounted equipment.

6" Depth Concrete Slab

If surface mounting equipment on existing slab using concrete anchors, the recommended thickness for the concrete is 6 inches. Follow the instructions of the anchor manufacturer for specific details on anchor usage (Concrete Anchors not provided)

PRE-INSTALLATION CHECK:

Compare all items received to the main packing list. Notify your sales representative immediately if any parts are missing or damaged. We are not responsible for items discovered missing after 72 hours from time of delivery!

COMMON INSTALLATION TOOLS

- A) 9/16" Wrench
- B) Wheelbarrow (to mix concrete)
- C) High Speed 3/8" Electric Drill w/clutch with 1/4" and 1/2" Bits
- D) String Level, Magnetic Level, 4' Level
- E) Large Flat Head Screwdriver
- F) Mallet
- G) Hack Saw
- H) Impact Gun
- I) Shovel / Post Hole Digger / Auger
- J) Pry Bar
- K) Tape Measure
- L) 3/16" and 1/4" Allen Head Wrench
- M) T-45 TORX Tool (supplied by the manufacturer)
- N) T-30 TORX Tool (supplied by the manufacturer)
- O) Straps and boards to help hold structure in a level position before and while concrete sets.

INSTALLATION GUIDELINES

Excavate holes in accordance with footing drawing. If the site cannot be graded level, adjust the depth of footings to maintain a level footing base. If soil conditions are loose or unstable, a larger diameter footing may be required.

After completing any required assembly, make sure equipment is level and plumb across the board before pouring concrete. Concrete with a minimum PSI of 2,500 must be used and should be mixed in accordance with manufacturer's specifications.

Never leave the installation site unattended without making sure that all fastening hardware on all equipment is tight. Failure to do so may result in injury or component damage.

Keep installation site roped off for at least 48 hours before equipment usage to allow concrete to harden.

Example of Typical Product Dimensions for Surface Mount Install

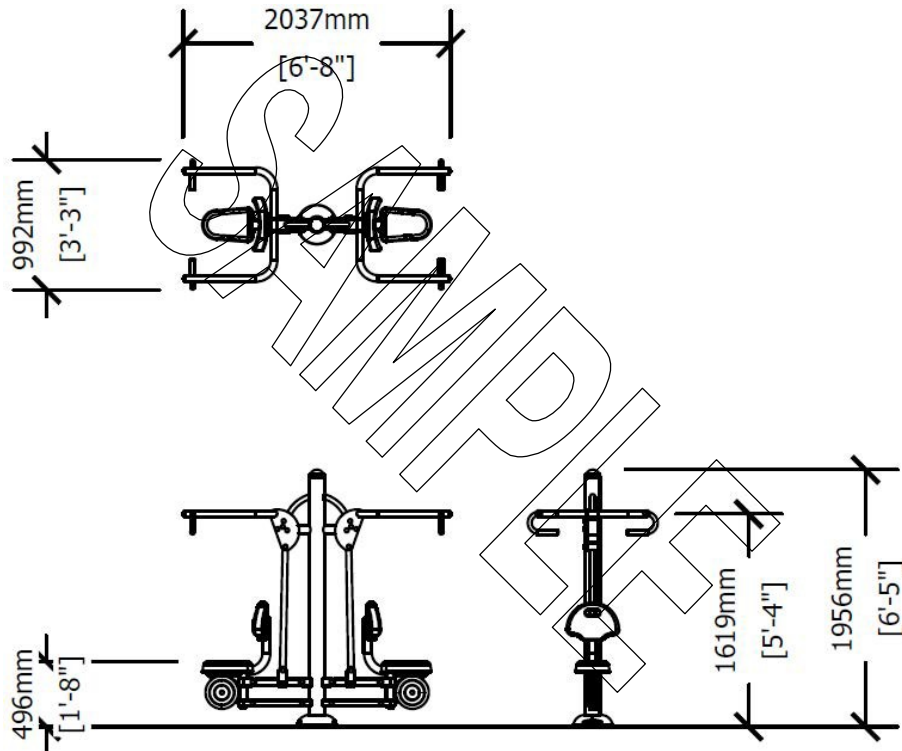

Example of Footer for In-Ground Mount

If no Safety Surfacing is Desired, dig footings to a 30-inch depth.

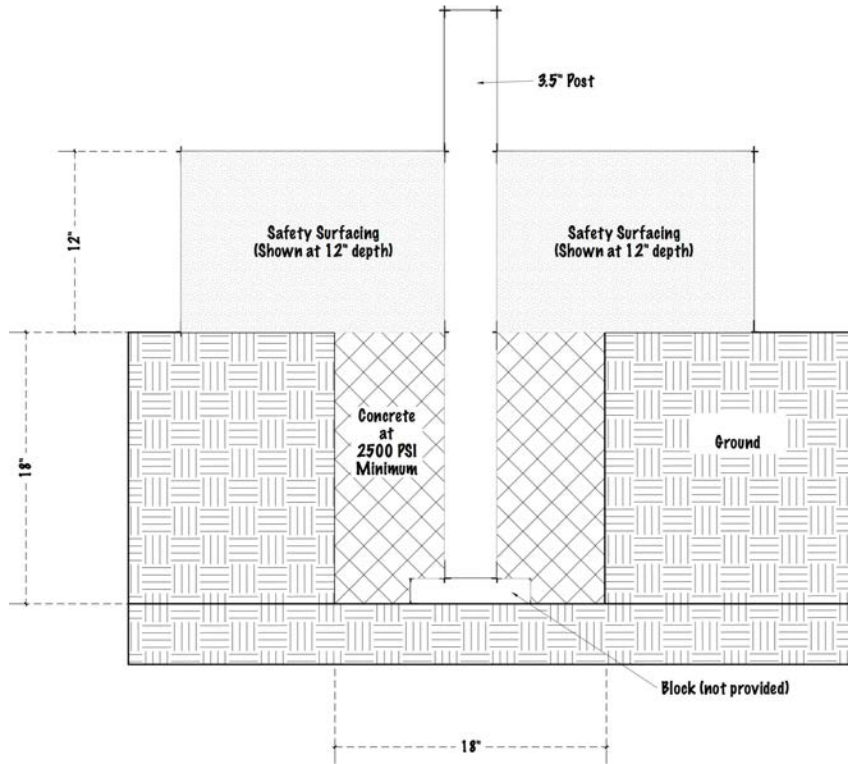

Example of Slab Install with Concrete Anchors

For installation without Safety Surfacing

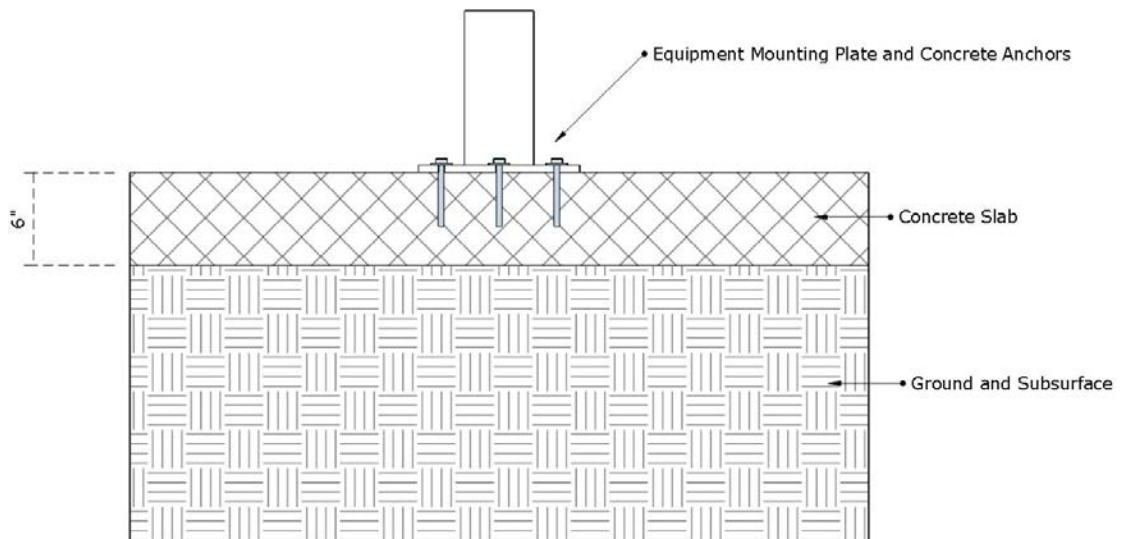

Double Station Lat Pulldown Install

STEP: 1

Use equipment onsite to measure placement for footings.

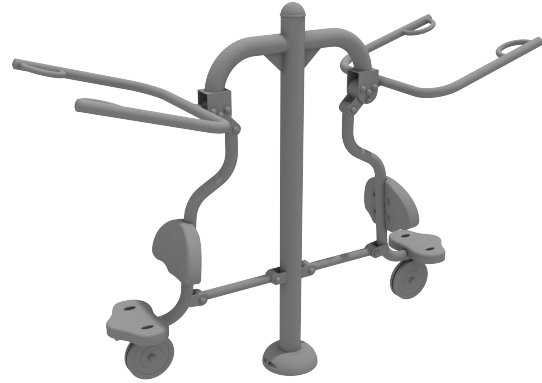

STEP: 2

DO NOT CEMENT POSTS/MOUNTS INTO PLACE UNTIL THE ENTIRE STRUCTURE IS ASSEMBLED.

Refer to the General Installation guide footing size information and digging proper holes for the support posts/mounts.

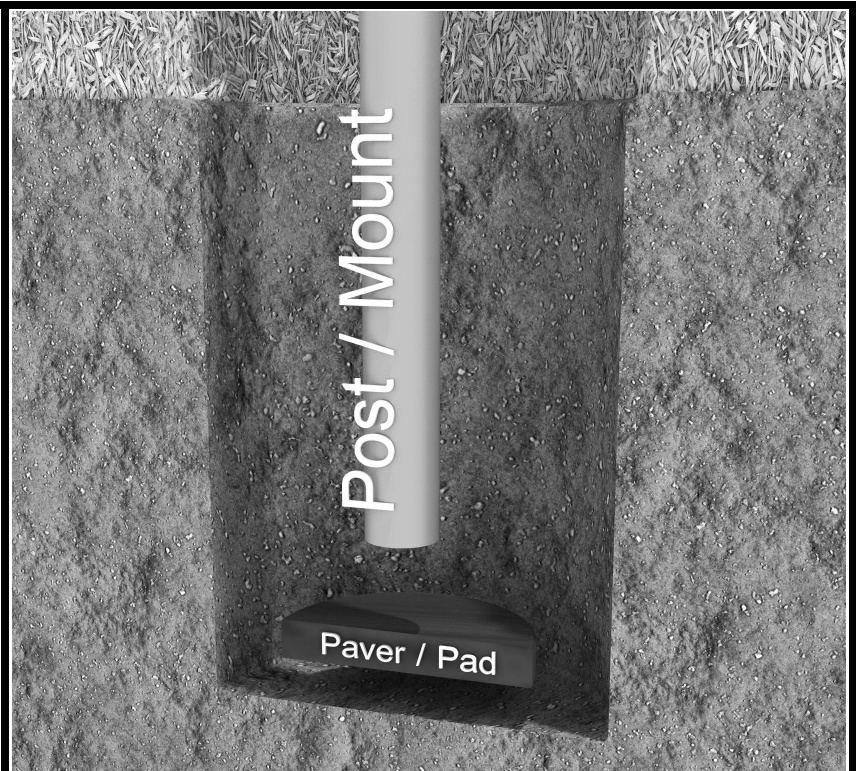

Double Station Lat Pulldown Install

STEP: 1

Connect plastic mount cover over the mounting plate and bolt the two pieces together using the supplied hardware.

