

*UP120-Climb & Discover Cave ABCD-1234 Handholds,
(Playful)*
*UP121-Climb & Discover Cave Standard Handholds,
(Natural)*

Parts List			
DESCRIPTION	UP120	UP121	PART NUMBER
FOOTBUCK	4	4	208100
CLIMB & DISCOVER CAVE	2	2	311341
CONNECTOR PLATE	1	1	311523
Hardware Complete	1	0	403744
Hardware Complete	0	1	403745
HANDHOLD PACKAGE (ABCD, 1234)	1	0	311352*
HANDHOLD PACKAGE (STANDARD)	0	1	311355*
5/16" x 1 1/2" P.B.H.C.S. w/PATCH	36	36	812047*
3/8" x 3/4" P.B.H.C.S. w/PATCH	8	8	812052*
3/8" x 1" P.B.H.C.S. w/PATCH	10	10	812050*
3/8" x 2" THREADED ROD	2	2	803560*
3/8" LOCK WASHER	10	10	817334*
3/8" FLAT WASHER	54	54	817410*
3/8" FLAT WASHER (1 1/4" O.D.)	2	2	817424*
3/8" HEX NUT	2	2	804053*
5/16" PIN-IN TORK BIT TT-40	1	1	812654*
3/8" PIN-IN TORX BIT TT-45	1	1	812655*
5/16" PIN-IN TORX KEY TT-40	1	1	812657*
3/8" PIN-IN TORX KEY TT-45	1	1	812658*

Unless Otherwise Specified, All Units of Measure are Each

Items listed below Hardware Complete line are included with Hardware Complete Number

Warning: During Installation, Hardware And Small Parts Are Choking Hazards For Young Children. Store Unused Parts Appropriately Until Assembly Is Completed. Once Assembly Is Completed, Remove Any Unused Parts From The Play Environment And Dispose/Save Them In A Secure Location. Any bolt end protruding more than two full threads beyond the face of the nut causes risk of clothing entanglement.

Promptly cut-off flush, file smooth, and treat to prevent corrosion.

Note: Peen Tee-Nuts and Flatwashers to match radius of pipe after assembly is complete.

Note: Loctite (supplied by others) should be used on any non-patch hardware.

Climb and Discover Cave:

Shall be 1/4" wall thickness double wall construction, color impregnated linear low density polyethylene and shall conform to the rotationally molded specifications outlined herein. All polyethylene shall be linear low-density material with UV-stabilized color and an anti-static compound additive. All rotationally molded products shall meet or exceed the following specifications: ASTM D-1248, type 2, class A and Federal specification LP-390C, type 1, class M, grade 2, category 3; Density (ASTM D- 1505); Brittleness Temperature (ASTM D-746); Tensile Values (ASTM D-638); Flexural Modulus (ASTM D-790); Heat Distortion (ASTM-648); Low Temperature Impact (ARM-STD).

Connector Plate:

Shall be fabricated from 1/4" x 4" hot rolled flat steel with a custom formula of TGIC polyester powder coating in conformance with the specifications outlined herein.

Footbuck:

Shall be an all welded construction fabricated from 2 3/8" O.D. (13ga.) galvanized steel tubing and 12ga steel sheet. The footbuck shall be coated after fabrication with a custom formula of TGIC polyester powder coating in conformance with the specifications outlined herein.

UP120-Climb & Discover Cave ABCD-1234 Handholds, (Playful) UP121-Climb & Discover Cave Standard Handholds, (Natural)

Handholds:

Shall be fabricated from a hybrid resin mixture with custom formulated UV inhibitor.

Hardware:

All nuts, bolts, screws, inserts, and lock washers used in the assembly of all play equipment shall be stainless steel, yellow dichromate plated steel, blue-coat plated steel, mechanically galvanized or powder coated/yellow dichromate plated steel. All primary fasteners shall be 304 alloy stainless steel. Fasteners with yellow dichromate treatment have an electro-deposited, 99.9% pure zinc substrate applied from a specially formulated solution sealed with a yellow dichromate top coat designed to work in conjunction with the zinc plating. Yellow dichromate has a 320% longer life to white corrosion and 275% longer to red corrosion than does hot-dip galvanizing. Stainless steel fasteners shall be button pin-in head, hex socket cap screws with a two-part epoxy locking patch added to the threads. The two-part locking patch shall consist of one part resin and one part catalyst which are activated during installation. After curing, the material shall require a minimum of five times the installation torque to remove the fastener. Manufacturer shall provide special installation tools for pinned fasteners.

INSTALLATION INSTRUCTIONS:

1. Dig footing holes as shown in Plan and Elevation Views. Place brick or equivalent in the bottom of hole to provide a solid foundation.
2. Attach Footbucks to bottom of Climb & Discover Cave using 3/8" x 3/4" P.B.H.C.S. w/Patch, 3/8" Lock Washer, and 3/8" Flat Washer. See Detail 595.
3. Insert 3/8" Threaded Rod into one end of each Climb & Discover Cave. **IMPORTANT: BE SURE TO INSTALL 3/8" THREADED ROD IN THE APPROPRIATE THREADED INSERT.** See Detail 697.
4. Slide the Climb & Discover Cave together, Attach 3/8" Flat Washer (1 1/4" O.D.), 3/8" Lock Washer, and 3/8" Hex Nut to Threaded Rod. **IMPORTANT: ALIGN CLIMB & DISCOVER CAVE TOP AND EDGES TOGETHER BEFORE TIGHTENING TO ELIMINATE GAPS ON THE ENDS.** See Detail 698.
5. After Climb & Discover Caves end are tightened attach Connector Plate to Climb & Discover Cave using 3/8" x 1" P.B.H.C.S w/Patch and 3/8" Flat Washer. See Detail 596.
6. Attach Handholds to Climb & Discover Cave using 5/16" x 1 1/2" P.B.H.C.S. w/Patch and 3/8" Flat Washer. See Detail 597. **IMPORTANT: DO NOT OVERTIGHTEN HANDHOLDS.**
7. Plumb and level the entire assembly and tighten all fasteners.
8. After entire unit is assembled, pour concrete footings within 4" to the top and taper away from posts for water drainage. Allow to cure at least 48 hours before use. **Note: Temporary bracing may be required until concrete cures.**
9. When the structure is finished and satisfactory, eliminate sharp points and sharp edges (burring) on installed hardware like bolts, nuts, etc. Install resilient surfacing material within the use zone of play structure in accordance with ASTM specifications F1292 appropriate for the fall height of each structure. Refer to the *Safety Guidelines*.

MAINTENANCE PROCEDURE:

Periodically check hardware for tightness, and tighten as necessary. Always check all parts for breakage or wear, and immediately put equipment out of service until any faulty parts found are repaired or replaced. Also Check all metal parts for rust, paint loss and touch-up if necessary with paint. Check for welded areas and verify integrity. Check periodically resilient surfacing for appropriate depth and remove extraneous materials that could cause injury, infection, or disease. Maintain detailed installation, inspection, maintenance, and repair records for each public-use playground equipment.

UP120-Climb & Discover Cave ABCD-1234 Handholds, (Playful)
UP121-Climb & Discover Cave Standard Handholds, (Natural)

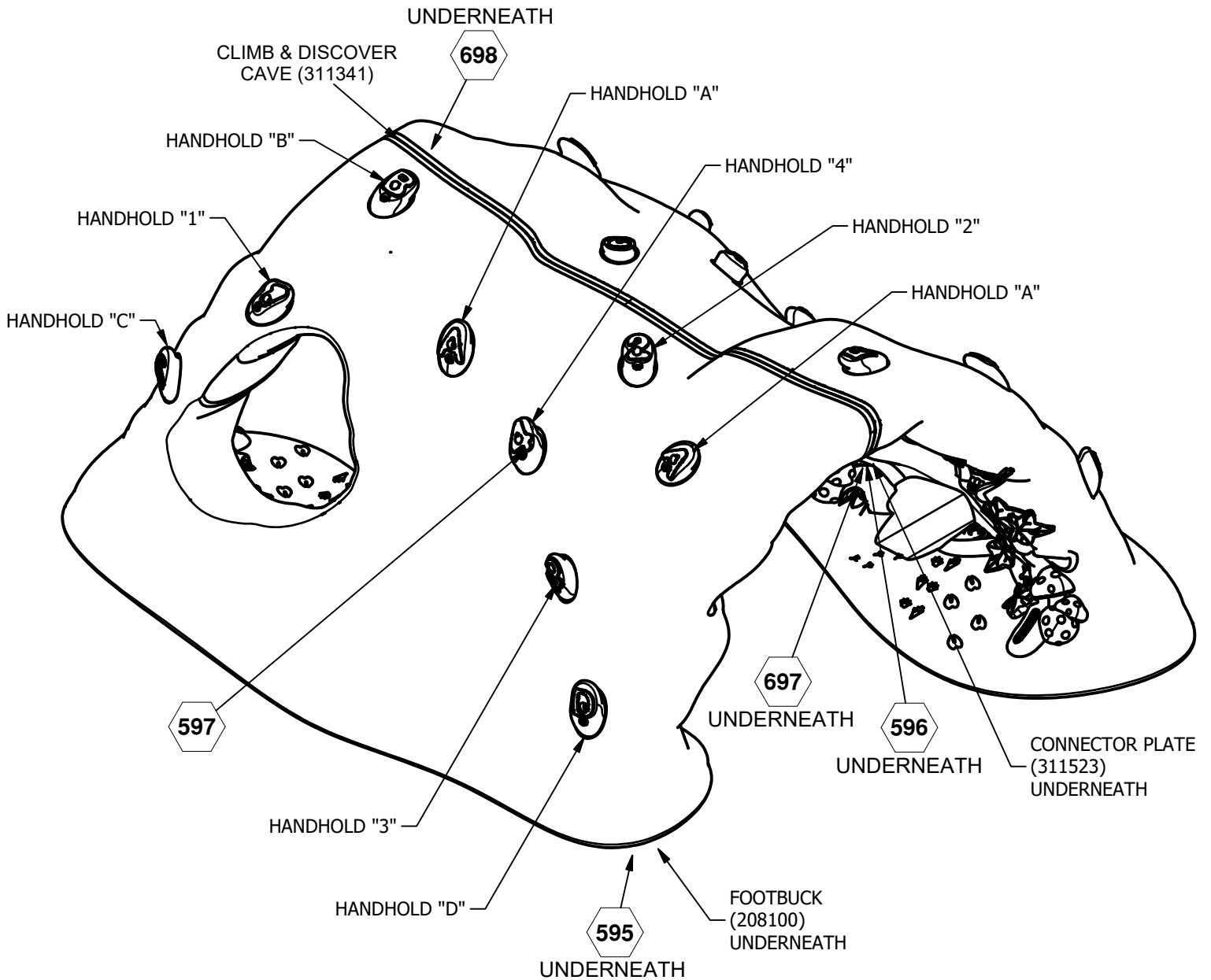

 = INSTALLATION DETAIL

FINISHED ASSEMBLY
UP120 SHOWN

UP120-Climb & Discover Cave ABCD-1234 Handholds, (Playful)
UP121-Climb & Discover Cave Standard Handholds, (Natural)

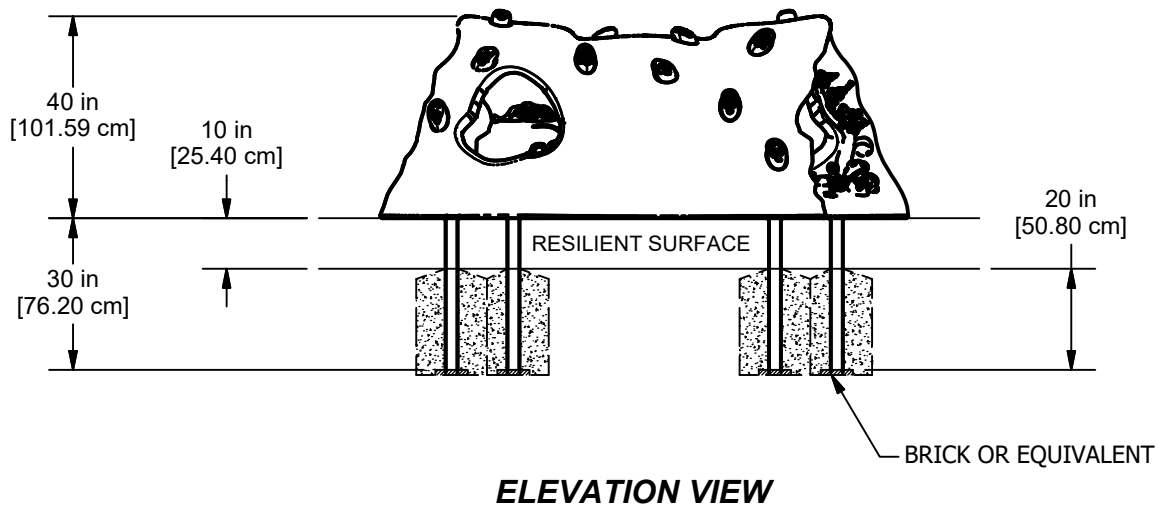
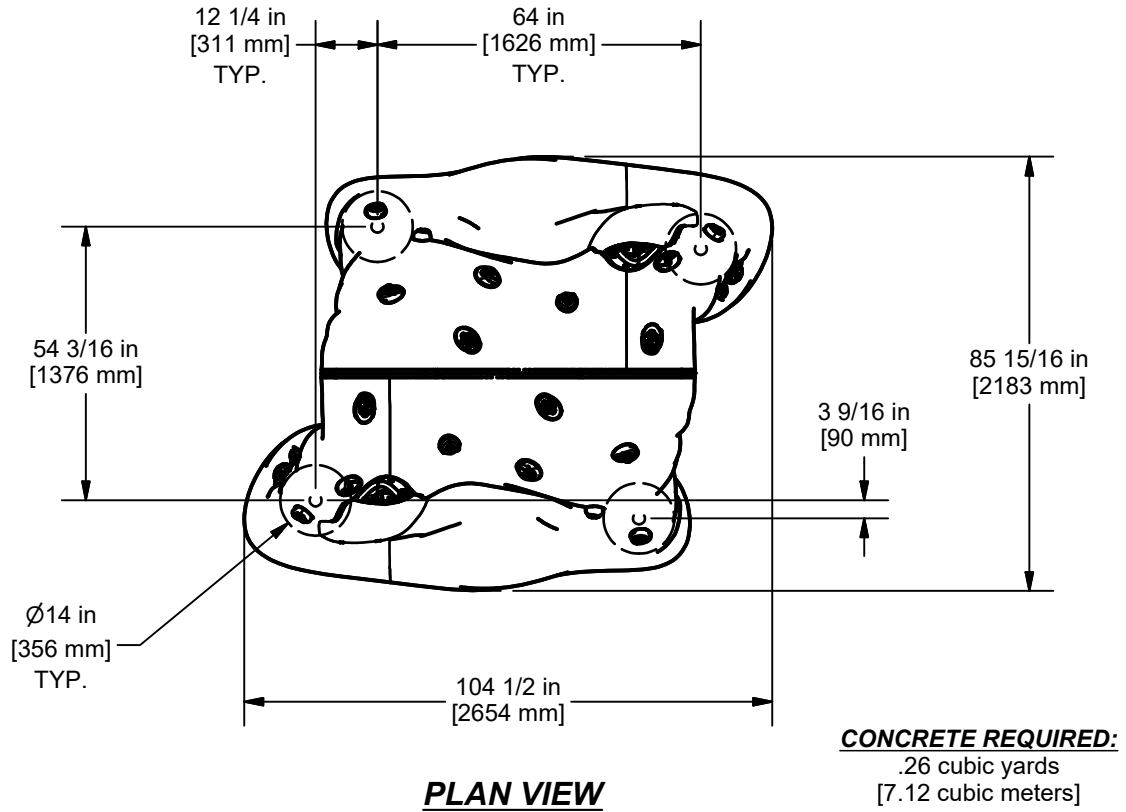

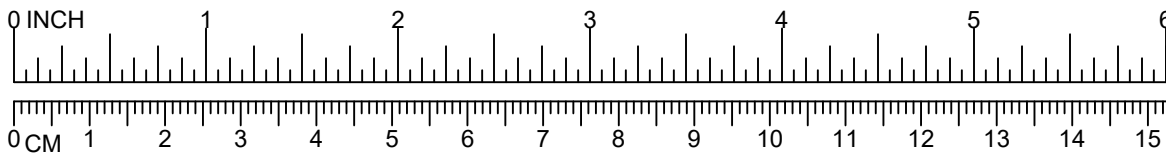

**UP120-Climb & Discover Cave ABCD-1234 Handholds,
(Playful)**
**UP121-Climb & Discover Cave Standard Handholds,
(Natural)**

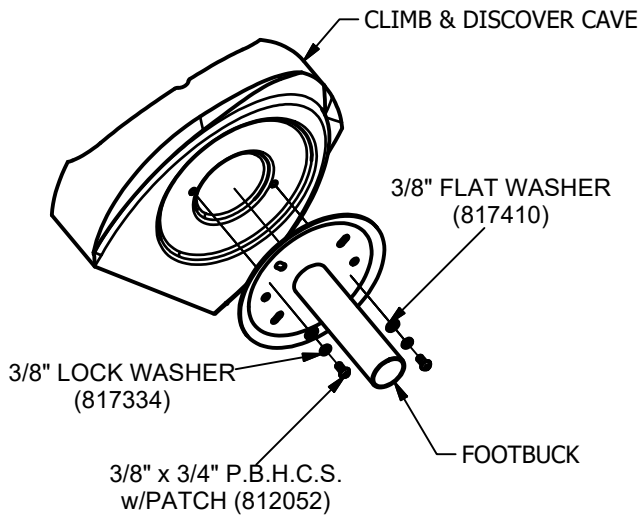

595

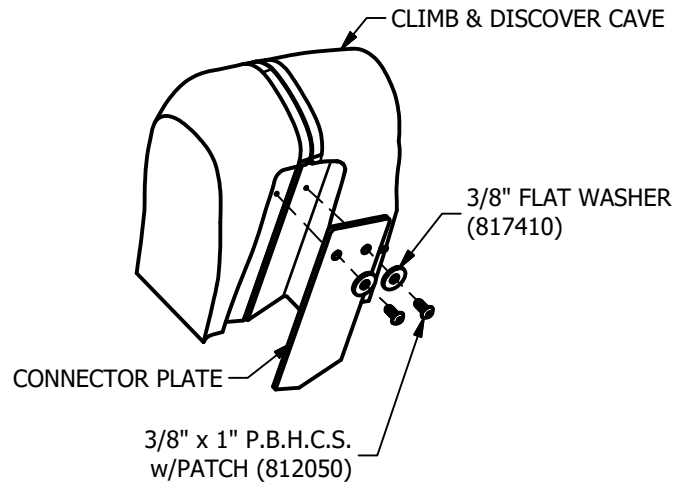

596

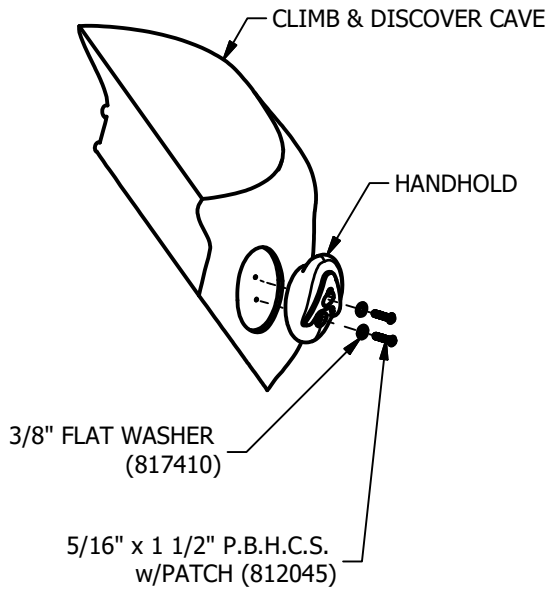

597

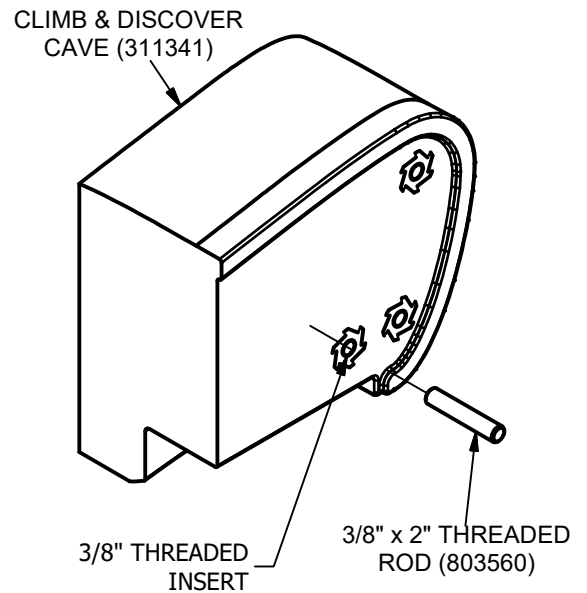

697

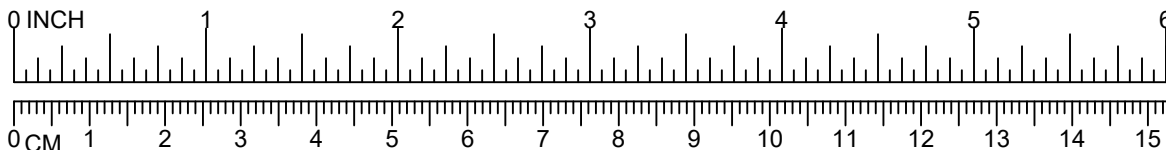

*UP120-Climb & Discover Cave ABCD-1234 Handholds,
(Playful)*
*UP121-Climb & Discover Cave Standard Handholds,
(Natural)*

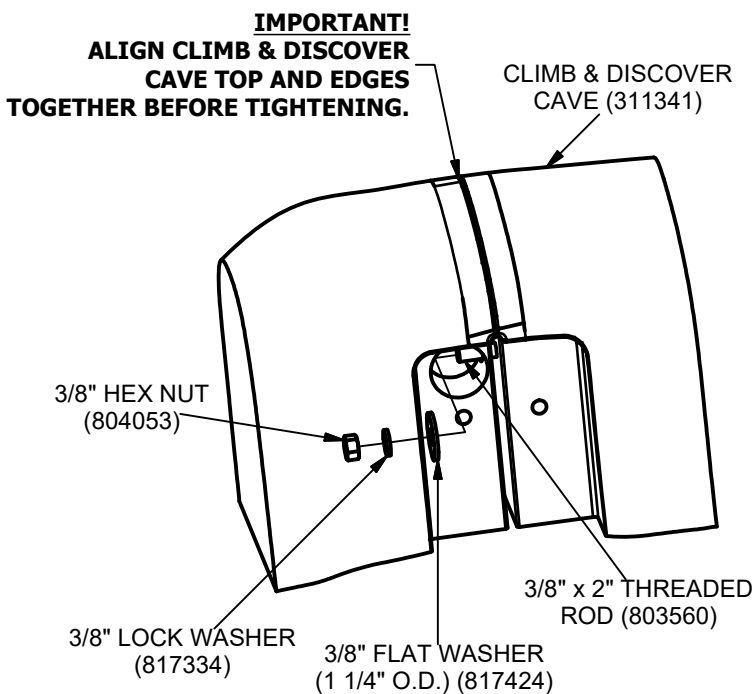

698